

# Government Gazette

OF

## WESTERN AUSTRALIA

(Published by Authority at 3.30 p.m.)

No. 29]

PERTH: FRIDAY, 28th APRIL

[1978

Premier's Department,  
Perth, 19th April, 1978.

IT is hereby notified for public information that the Governor has approved of the following temporary allocation of portfolios during the absence from the State of the Hon. D. H. O'Neil, M.L.A., from Friday 28th April, 1978, to Sunday, 14th May (both dates inclusive)—

Hon. R. C. Old, M.L.A., to be Acting Deputy Premier.

Hon. I. G. Medcalf, Q.C., M.L.C., to be Acting Chief Secretary.

Hon. R. J. O'Connor, M.L.A., to be Acting Minister for Police and Traffic.

R. D. DAVIES,  
Under Secretary.

### LAND AGENTS ACT, 1921.

Application for License in the First Instance.

To the Court of Petty Sessions at Perth:  
I, ROGER SANDFORD HOWELL, of 127 Blackall Drive, Greenwood, Real Estate Manager, having attained the age of twenty-one years, hereby apply on my behalf for a license to carry on the business of a land agent under the Land Agents Act, 1921. The principal place of business will be at c/o 9 Hutton Street, Osborne Park, W.A.

Dated the 20th day of April, 1978.

R. S. HOWELL,  
Signature of Applicant.

### Appointment of Hearing.

I hereby appoint the 30th day of May, 1978, at 2.15 o'clock in the afternoon as the time for the hearing of the foregoing application at the Court of Petty Sessions at Perth.

Dated the 20th day of April, 1978.

K. W. SHEEDY,  
Clerk of Petty Sessions.

Objection to the granting of the application may be served on the applicant and the Clerk of Petty Sessions at any time prior to seven days before the date appointed for the hearing.

### LAND AGENTS ACT, 1921.

Application for Transfer of a License.

To the Court of Petty Sessions at Perth:

I, ROBERT JAMES DWYER, of 98 Bateman Road, Mt. Pleasant, hereby apply as nominee of Skyline Homes a division of Jaxon Construction Pty. Ltd. for the license currently issued to Robert James Dwyer on his own behalf trading as R. J. Dwyer, to be transferred to me to carry on business as a Land agent at 190 Hay Street, East Perth, W.A. 6000.

Dated the 14th day of April, 1978.

R. J. DWYER,  
Signature of Applicant (Transferee).

I, Robert James Dwyer, concur in this application.

R. J. DWYER,  
Signature of Transferor.

## Appointment of Hearing.

I hereby appoint the 23rd day of May, 1978, at 2.15 o'clock in the afternoon as the time for the hearing of the foregoing application at the Court of Petty Sessions at Perth.

Dated the 14th day of April, 1978.

K. W. SHEEDY,  
Clerk of Petty Sessions.

Objection to the granting of the license may be served on the applicant and the Clerk of Petty Sessions at any time prior to seven days before the date appointed for the hearing.

## LAND AGENTS ACT, 1921.

## Application for Transfer of a License.

To the Court of Petty Sessions at Perth:

I, RICHARD WILLIAM PEEL, of 71 Hardy Road, Nedlands, hereby apply on behalf of a firm Peel/Shields Real Estate the partners of which are Robert William Shields, Ian Keith Nordahl, Richard William Peel, for the license currently issued to Richard William Peel, to be transferred to me to carry on business as a Land agent at 872 Albany Highway, East Victoria Park.

Dated the 18th day of April, 1978.

R. W. PEEL,  
Signature of Applicant (Transferee).

I, Richard William Peel, concur in this application.

R. W. PEEL,  
Signature of Transferor.

## Appointment of Hearing.

I hereby appoint the 30th day of May, 1978, at 2.15 o'clock in the afternoon as the time for the hearing of the foregoing application at the Court of Petty Sessions at Perth.

Dated the 18th day of April, 1978.

K. W. SHEEDY,  
Clerk of Petty Sessions.

Objection to the granting of the license may be served on the applicant and the Clerk of Petty Sessions at any time prior to seven days before the date appointed for the hearing.

## LAND AGENTS ACT, 1921.

## Application for License in the First Instance.

To the Court of Petty Sessions at Fremantle:

I, THOMAS MICHAEL PELL, of 12 Rosendo Street, Mosman Park 6012, Real Estate Salesman, having attained the age of twenty-one years, hereby apply on my behalf (on behalf of T. M. & L. M. Pell, a firm of which I am a member) for a license to carry on the business of a land agent under the Land Agents Act, 1921. The principal place of business will be at 12 Rosendo Street, Mosman Park.

Dated the 19th day of April, 1978.

T. M. PELL,  
Signature of Applicant.

## Appointment of Hearing.

I hereby appoint the 29th day of May, 1978, at 9.30 o'clock in the forenoon as the time for the hearing of the foregoing application at the Court of Petty Sessions at Fremantle.

Dated the 21st day of April, 1978.

D. G. DOIG,  
Clerk of Petty Sessions.

Objection to the granting of the application may be served on the applicant and the Clerk of Petty Sessions at any time prior to seven days before the date appointed for the hearing.

## LAND AGENTS ACT, 1921.

## Application for Transfer of a License.

To the Court of Petty Sessions at Perth:

I, ROBERT DOUGLAS STIRLING, of 10 Collins Road, Kalamunda, hereby apply on behalf of a firm Stirling & Davis, the partners of which are Robert Douglas Stirling, Robert George Davis, for the license currently issued to Robert Douglas Stirling, on his own behalf trading as Robert Douglas Stirling, to be transferred to me to carry on business as a Land agent at 370 Canning Highway, Como.

Dated the 21st day of April, 1978.

R. D. STIRLING,  
Signature of Applicant (Transferee).

I, Robert Douglas Stirling, concur in this application.

R. D. STIRLING,  
Signature of Transferor.

## Appointment of Hearing.

I hereby appoint the 30th day of May, 1978, at 2.15 o'clock in the afternoon as the time for the hearing of the foregoing application at the Court of Petty Sessions at Perth.

Dated the 24th day of April, 1978.

K. W. SHEEDY,  
Clerk of Petty Sessions.

Objection to the granting of the license may be served on the applicant and the Clerk of Petty Sessions at any time prior to seven days before the date appointed for the hearing.

## LAND AGENTS ACT, 1921.

## Application for License in the First Instance.

To the Court of Petty Sessions at Fremantle:

I EILEEN RAY FEWTRELL, of 51 Links Road, Ardross, 6153, Housewife and Mother, having attained the age of twenty-one years, hereby apply on my behalf for a license to carry on the business of a land agent under the Land Agents Act, 1921. The principal place of business will be at 51 Links Road, Ardross, 6153.

Dated the 14th day of April, 1978.

E. R. FEWTRELL,  
Signature of Applicant.

## Appointment of Hearing.

I hereby appoint the 22nd day of May, 1978, at 9.30 o'clock in the forenoon as the time for the hearing of the foregoing application at the Court of Petty Sessions at Fremantle.

Dated the 14th day of April, 1977.

D. G. DOIG,  
Clerk of Petty Sessions.

Objection to the granting of the application may be served on the applicant and the Clerk of Petty Sessions at any time prior to seven days before the date appointed for the hearing.

## LAND AGENTS ACT, 1921.

## Application for License in the First Instance.

To the Court of Petty Sessions at Perth:

I, BRENDON MICHAEL HUBBLE, of 294 The Boulevard, City Beach, W.A. 6015, Company Director, having attained the age of twenty-one years, hereby apply on my behalf for a license to

carry on the business of a land agent under the Land Agents Act, 1921. The principal place of business will be at c/o Justin Seward Pty. Ltd., 77 St. George's Terrace, Perth (non operating).

Dated the 24th day of April, 1978.

B. M. HUBBLE,  
Signature of Applicant.

Appointment of Hearing.

I hereby appoint the 6th day of June, 1978, at 2.15 o'clock in the afternoon as the time for the hearing of the foregoing application at the Court of Petty Sessions at Perth.

Dated the 26th day of April, 1978.

K. W. SHEEDY,  
Clerk of Petty Sessions.

Objection to the granting of the application may be served on the applicant and the Clerk of Petty Sessions at any time prior to seven days before the date appointed for the hearing.

Western Australia.

FINANCE BROKERS CONTROL ACT, 1975.

(Sections 24 and 27.)

Application for Finance Brokers License  
by Individual.

To the Registrar, Finance Brokers Supervisory Board:

I, GRAEME JOHN HERON, of 25 Celestine Street, Wanneroo, hereby apply for a Finance Brokers License under the Finance Brokers Control Act, 1975. My address for service of notices in respect of this application is 21 Rheola Street, West Perth.

Signed GRAEME JOHN HERON.

Appointment of Hearing.

I hereby appoint the 10th day of May, 1978, at 9 o'clock in the forenoon as the time for hearing the foregoing application at the Offices of the Finance Brokers Supervisory Board, 184 St. George's Terrace, Perth.

D. P. MANEA,  
Registrar,  
Finance Brokers Supervisory Board.

Objection to the granting of this license shall be in the approved form and may be served on the applicant and the Registrar at any time prior to seven days before the date appointed for the hearing.

Western Australia.

FINANCE BROKERS CONTROL ACT, 1975.

(Sections 24 and 27.)

Application for Finance Brokers License  
by Individual.

To the Registrar, Finance Brokers Supervisory Board:

I, JOHN JANSEN, of 7 Engler Street, Booragoon, hereby apply for a Finance Brokers License under the Finance Brokers Control Act, 1975. My address for service of notices in respect of this application is 21 Rheola Street, West Perth.

Dated this 3rd day of April, 1978.

Signed JOHN JANSEN.

Appointment of Hearing.

I hereby appoint the 10th day of May, 1978, at 9 o'clock in the forenoon as the time for hearing the foregoing application at the Offices of the Finance Brokers Supervisory Board, 184 St. George's Terrace, Perth.

D. P. MANEA,  
Registrar,  
Finance Brokers Supervisory Board.

Objection to the granting of this license shall be in the approved form and may be served on the applicant and the Registrar at any time prior to seven days before the date appointed for the hearing.

Western Australia.

FINANCE BROKERS CONTROL ACT, 1975.

(Sections 24 and 27.)

Application for Finance Brokers License by  
Individual.

To The Registrar Finance Brokers Supervisory Board.

I, KENNETH ROSS STEWART, of Unit 3 The Sandpiper, 291 West Coast Highway, Scarborough hereby apply for a Finance Brokers License under the Finance Brokers Control Act, 1975. My address for service of notices in respect of this application is 21 Rheola Street, West Perth.

Dated this 3rd day of April, 1978.

Signed KENNETH ROSS STEWART.

Appointment of Hearing.

I hereby appoint the 10th day of May, 1978 at 9 o'clock in the forenoon as the time for hearing the foregoing application at the Offices of the Finance Brokers Supervisory Board, 184 St. George's Terrace, Perth.

D. P. MANEA,  
Registrar,  
Finance Brokers Supervisory Board.

Objection to the granting of this license shall be in the approved form and may be served on the applicant and the Registrar at any time prior to seven days before the date appointed for the hearing.

Western Australia.

FINANCE BROKERS CONTROL ACT, 1975.

(Sections 24 and 29.)

Application for Finance Brokers License by  
Corporate Body.

To The Registrar, Finance Brokers Supervisory Board.

WESTSIDE FINANCE GROUP PTY. LTD. T/AS WESTSIDE LEASE & FINANCIAL SERVICES hereby applies for a Finance Brokers License under the Finance Brokers Control Act, 1975. The address for service of notices in respect of this application is 21 Rheola Street, West Perth.

Dated this 3rd day of April, 1978.

Signed GRAEME JOHN HERON,  
Director.

Appointment of Hearing.

I hereby appoint the 10th day of May, 1978, at 9 o'clock in the forenoon as the time for hearing the foregoing application at the Offices of the Finance Brokers Supervisory Board, 184 St. George's Terrace, Perth.

D. P. MANEA,  
Registrar,  
Finance Brokers Supervisory Board.

Objection to the granting of this license shall be in the approved form and may be served on the applicant and the Registrar at any time prior to seven days before the date appointed for the hearing.

Public Service Board,  
Perth, 28th April, 1978.

THE following promotions have been approved:—

M. I. Schorer, Laboratory Assistant, G-X, to be Laboratory Technician Grade 2, G-II-1/4, Seed Products Branch, Plant Research Division, Department of Agriculture as from May 5, 1978.

H. Verstegen, Clerk, C-II-1, to be Clerk, C-II-2, Accounts Branch, Department of Agriculture as from March 17, 1978.

S. C. Curtain, Clerk, C-IV, to be Clerk, C-II-1, Audit Department as from April 21, 1978.

R. G. Isted, Clerk, C-II-1, to be Clerk, C-II-1/2, Audit Department as from April 14, 1978.

W. G. Stevens, Clerk, C-IV, to be Clerk, C-II-1, Audit Department as from April 21, 1978.

I. Rose, Cashier, C-II-1, Forests Department, to be Clerk, C-II-1, Finance Section, Accounts Branch, Department for Community Welfare as from March 10, 1978.

K. Posney, Probation and Parole Officer, Level 1, to be Senior Probation and Parole Officer, Level 2, Crown Law Department as from March 24, 1978.

L. W. Cochrane, Superintendent of Education Technical, Level 2, to be Assistant Director of Resources Technical Education, Level 3, Professional Branch, Education Department as from April 12, 1978.

B. A. Doyle, Clerk, C-II-1, Department of Mines, to be Clerk, C-II-2, Staff (Non Teaching) Section, Clerical Branch, Education Department as from April 14, 1978.

V. M. Hall, Assistant Director Operations Technical Education, Level 3, to be Director of Operations Technical Education, Level 4, Professional Branch, Education Department as from April 12, 1978.

C. H. McDonald, Clerk, C-II-3, to be Clerk, C-II-4, Clerical Branch, Technical Education Division, Education Department as from March 31, 1978.

A. A. Powell, Maintenance Officer, C-II-2/3, Department for Community Welfare, to be School Welfare Officer, G-II-2/4, School Welfare Branch, Education Department as from March 3, 1978.

B. V. Bentley, Clerk, C-II-1, Crown Law Department, to be Clerk, C-II-2, Finance Branch, Division of Industries, Department of Industrial Development as from March 17, 1978.

R. R. Gould, Clerk, C-II-2, Education Department, to be Investigations Officer, C-II-4, Finance Branch, Division of Industries, Department of Industrial Development as from March 10, 1978.

R. A. Higham, Clerk, C-II-2, Public Works Department, to be Clerk, C-II-3, Finance Branch, Division of Industries, Department of Industrial Development as from March 17, 1978.

A. G. Short, Clerk, C-II-3, to be Clerk Relieving, C-II-4, Administrative Branch, Division of Industries, Department of Industrial Development as from April 7, 1978.

P. M. Higgs, Inspector Grade 3, G-II-1/2, to be Inspector Grade 1, G-II-4/5, Factories and Shops Section, Inspection and Technical Services Branch, Department of Labour and Industry as from March 24, 1978.

T. J. Holder, Clerk, C-IV, to be Clerk, C-II-1, Pastoral Leases Section, Registration and Deeds Branch, Department of Lands and Surveys as from March 31, 1978.

B. Hooson, Clerk, C-IV, to be Clerk, C-II-1, Reserves and General Section, Roads and Reserves Branch, Department of Lands and Surveys as from March 31, 1978.

B. M. Byrne, Clerk, C-II-3, to be Clerk In Charge, C-II-4, Automatic Data Processing Section, Services Branch, Accounts Division, Metropolitan Water Board as from March 10, 1978.

A. D. M. Glendenning, Local Authority Liaison Officer, G-II-2, to be Area Co-Ordinator, G-II-5/6, State Civil Emergency Service, Premier's Department as from December 30, 1977.

W. D. Boylan, Clerk, C-IV, to be Clerk, C-II-1, Clerical Section, Community and Child Health Services, Public Health Department as from February 17, 1978.

G. S. Faulkner, Assistant Principal Technologist, Level 5, to be Deputy Principal Technologist, Level 6, State Health Laboratories, Public Health Department as from April 12, 1978.

M. L. Rowe, Clerk, C-II-1, to be Clerk, C-II-2, Clerical Section, Community and Child Health Services, Public Health Department as from March 24, 1978.

J. C. Caro, Structural Engineer, Level 2, to be Structural Engineer, Level 3, Design Office, Structures Engineering Design and Construction Branch, Architectural Division, Public Works Department as from April 12, 1978.

R. Johnson, Structural Engineer, Level 2, to be Structural Engineer, Level 3, Design Office, Structures Engineering Design and Construction Branch, Architectural Division, Public Works Department as from April 12, 1978.

B. J. Loughton, Engineer, Level 2, to be Engineer, Level 3, Pilbara Section, Operations North Branch, Engineering Division, Public Works Department as from April 12, 1978.

R. Martyn, Clerk, C-IV, to be Clerk Relieving, C-II-1, Clerical Section, Architectural Division, Public Works Department as from April 7, 1978.

M. A. Naismith, Structural Engineer, Level 2, to be Structural Engineer, Level 3, Construction Section, Structures Engineering Design and Construction Branch, Architectural Division, Public Works Department as from April 12, 1978.

D. M. Whitford, Clerk, C-IV, to be Clerk, C-II-1, Albany District Water Supply Office, Accounts Division, Public Works Department as from April 7, 1978.

F. J. W. Young, Architect, Level 2, to be Architect, Level 3, The Queen Elizabeth II Medical Centre, Hospital Design and Investigation Branch, Architectural Division, Public Works Department as from April 12, 1978.

G. E. Astill, Collector, C-II-1, State Housing Commission, to be Clerk, C-II-2, Geraldton Branch Office, Clerical Division, Road Traffic Authority as from March 31, 1978.

R. W. Simpson, Clerk, C-II-1, to be Cashier, C-II-2, Revenue and Expenditure Section, Accounts Division, Road Traffic Authority as from April 7, 1978.

G. W. Maher, Clerk, C-IV, Public Works Department, to be Clerk, C-II-1, North West Section, Country Branch, Housing Division, State Housing Commission as from April 7, 1978.

R. H. Dyson, Tourist Officer, C-II-1, to be Senior Tourist Officer, C-II-2, Perth Travel Centre, Department of Tourism as from March 31, 1978.

R. G. Bass, Equipment Operator, C-IV, to be Senior Computer Operator, C-II-1, Operations Section, Data Processing Centre, Treasury Department as from March 24, 1978.

P. J. Crispin, Computer Operator, C-IV, to be Senior Computer Operator, C-II-1, Operations Section, Data Processing Centre, Treasury Department as from February 3, 1978.

B. E. O'Malley, Manager, C-II-11, Education Department, to be Assistant Controller, A-I-1, Administrative Division, Government Stores Department, Treasury Department as from April 12, 1978.

THE following resignations have been accepted:—

Name; Department; Date.

F. W. Ferguson; Audit Department; 28/4/78.

H. M. Mein; Department for Community Welfare; 28/4/78.

J. Glac; Education Department; 29/3/78.

M. L. Norton; Education Department; 20/4/78.

V. L. O'Brien; Education Department; 28/4/78.

G. M. Bridger; Department of Fisheries and Wildlife; 28/4/78.

B. C. Bruce; Department of Fisheries and Wildlife; 28/4/78.

G. R. Martin; Department of Fisheries and Wildlife; 14/4/78.

C. Smith; Department of Industrial Development; 28/4/78.

J. M. Ellis; Department of Lands and Surveys; 14/4/78.  
 K. D. Johnston; Metropolitan Water Board; 28/4/78.  
 G. V. Coles; Public Health Department; 28/4/78.  
 I. Coles-Rutishauer; Public Health Department; 28/4/78.  
 L. V. Connop; Public Works Department; 29/3/78.  
 J. M. Cruttenden; State Housing Commission; 21/4/78.  
 L. F. Stafford; State Housing Commission; 28/4/78.

THE following retirement has been approved:—

Name; Department; Date.

F. R. Dodds; Crown Law Department; 18/4/78.

THE following appointments have been confirmed:—

Name; Position; Department; Date.

Hercocck, Harry William; Clerk, C-IV; Agriculture; 26/9/77.  
 Smith, Dianne Elizabeth; Field Assistant, G-X; Agriculture; 13/6/77.  
 Broadway, Judith Lee, Social Worker, Level 1; Community Welfare; 14/7/77.  
 Butters, Sandra Margaret; Clerk Typist, C-V; Community Welfare; 24/2/77.  
 McQueen, Robin Margaret; Clerk Typist, C-V; Community Welfare; 23/9/77.  
 Trifunovich, Angelina; Clerk, C-IV; Lands and Surveys; 27/10/77.  
 Forbes, Eileen; Accounting Machinist, C-V; Medical; 29/10/76.  
 Bowker, Audrey; Typist, C-V; Mental Health Services; 8/7/77.  
 Buckley, Marilyn Winifred; Occupational Therapist, Level 1; Mental Health Services; 18/4/77.  
 Hewson, Jannette May; Psychologist, Level 1; Mental Health Services; 17/5/77.  
 Vogels, Guido John; Social Worker, Level 1; Mental Health Services; 13/1/77.  
 Messenger, Tony George; Clerk, C-IV; Police; 11/10/77.  
 Burrell, Angela Eileen; Typist, C-V; Premier's; 10/11/76.  
 Bestall, Leanne Evellen; Clerk, C-IV; Public Health; 25/10/77.  
 Ibbotson, Hazel; Typist, C-V; Public Health; 19/8/77.  
 Itzstein, John Michael; Health Surveyor Grade 2, G-II-3/4; Public Health; 21/10/77.  
 Langford, James Herbert; Chemist and Research Officer, Level 1; Public Health; 19/10/77.  
 Wilkinson, Gavin Frederick; Trainee Graduate Assistant, C-IV; Public Service Board; 31/8/77.  
 Bishop, Ross Phillip; Drafting Assistant, G-XI; Public Works; 28/2/77.  
 Brophy, Jan Elizabeth; Data Processing Operator, C-V; Public Works; 1/8/77.  
 Name; Position; Department; Date.  
 Isaacs, Mary Theresa; Typist, C-V; Public Works; 3/5/77.  
 Rudolfs, Valda; Typist, C-V; Public Works; 29/10/76.  
 Billi, Viviana Anna; Clerk, C-IV; Road Traffic Authority; 20/10/77.  
 Oates, Carol Joy; Clerk, C-IV; State Government Insurance Office; 17/10/77.  
 Spalding, Deanne Therese; Clerk, C-IV; State Government Insurance Office; 17/10/77.

Cochrane, Jennifer Joyce; Clerk, C-IV; State Housing Commission; 17/10/77.

Garland, Lynn; Clerical Assistant, C-IV; Town Planning; 8/9/77.

Maffey, Helen Lynette; Typist, C-V; Treasury; 27/10/77.

Parton, Veronica Judith; Data Processor Operator, C-V; Treasury; 24/10/77.

THE following office has been created:—

Item 39 0044, Research Officer, Level 1, Special Services Section, Executive Branch, Department of Conservation and Environment.

THE title and/or classification of the following offices have been amended:—

Item 01 1190, occupied by P. G. Buckman, Veterinary Officer, Veterinary Services Branch, Animal Health Division, Department of Agriculture amended from Level 1 to Level 2, with effect from April 24, 1978.

Item 01 1192, occupied by D. P. McKenzie, Veterinary Officer, Veterinary Services Branch, Animal Health Division, Department of Agriculture amended from Level 1 to Level 2, with effect from April 24, 1978.

Item 10 1661, vacant, C-VI, Field Division, Department for Community Welfare amended from Clerical Assistant, to Clerical Assistant Fitzroy Crossing, with effect from April 24, 1978.

Item 16 0455, occupied by D. A. Hancock, Chief Research Officer, Fisheries Research Branch, Department of Fisheries and Wildlife amended from Level 7, to Level 8, with effect from April 18, 1978.

Item 08 2475, vacant, Inspection Meat Section, Inspection Health Act Branch, Professional Division, Public Health Department amended from Health Surveyor Grade 2, G-II-3/4, to Health Surveyor Grade 3, G-II-2/3 and renumbered as item 08 2610 with effect from April 24, 1978.

Item 08 2560, vacant, Inspection Meat Section, Inspection Health Act Branch, Professional Division, Public Health Department amended from Health Surveyor Grade 2, G-II-3/4, to Health Surveyor Grade 3, G-II-2/3 and renumbered as item 08 2615 with effect from April 24, 1978.

#### STATE X-RAY LABORATORIES

Verdun Street, Nedlands.

Clerk-Typist, C-III-1.

A secretary is required for the Physics Division of the State X-Ray Laboratories. The Division is responsible for the administration of the Radiation Safety Act, and the duties of the position include supervision of the processing of licences under the Act and the maintenance of licence records.

Applicants must be competent typists (shorthand and audio) and experienced in office procedures and staff control.

Salary: \$8 672 per annum.

Experienced typists who are interested in the above position are invited to contact the Public Service Board (telephone 322 1300, extension 220) by 12th May, 1978.

A secondment may be arranged should the successful applicant be a permanent officer of the Public Service.

## VACANCIES IN THE PUBLIC SERVICE

Department	Item No.	Position	Classn.	Salary
<b>Closing May 5, 1978</b>				\$
Agriculture	01 0400	Clerk, Accounts Branch	C-II-1	9 847-10 165
Agriculture	01 3053	Laboratory Assistant, Seed Products Branch, Plant Research Division (a) (c) (2) (3)	G-X	3 996-9 439
Agriculture	01 3060	Field Assistant, Seed Products Branch, Plant Research Division (a) (4) (5)	G-X	4 710-9 439
Community Welfare	10 0023	Deputy Chief of Institutional Services, Administrative Division (57)	Level 5	20 860
Community Welfare	10 0055	Secretary Stenographer, Administrative Division	C-III-3/4	9 560-10 399
Community Welfare	10 0116	Clerk, Relieving Staff Branch (c)	C-II-1	9 847-10 165
Community Welfare	10 3151	Clinical Psychologist, Institutional Services (a) (6) (7)	Level 1	14 789-15 760
Conservation and Environment	39 0032	Environmental Officer Pilbara, Executive Branch (a) (8) (12) (18)	Level 2/3	15 090-18 975 (22)
Crown Law	12 1070	Clerk, Accounts Branch, Public Trust Office (c)	C-II-1	9 847-10 165
Crown Law	13 0064	Clerk, Acceptance Branch, Office of Titles (c)	C-II-1	9 847-10 165
Education	14 0075	Speech Therapist, Professional Branch (a) (23)	Level 1	10 448-14 481
Education	14 1316	Clerk, Staff Section, Clerical Branch (c)	C-II-1/2	9 847-10 797
Education	14 3712	Clerk, Clerical Branch, Technical Education Division	C-II-2	10 482-10 797
Education	14 3720	Clerk, Clerical Branch, Technical Education Division (c)	C-II-2	10 482-10 797
Education	14 3778	Technical Officer, Clerical Branch, Technical Education Division (a) (25)	G-II-3/4	11 057-12 118
Education	14 3800	Clerk of Examinations, Examination Centre, Clerical Branch, Technical Education Division	C-II-5	12 573-12 938
Fisheries and Wildlife	16 0897	Inspector Relieving—Seagoing, Fisheries Inspection Branch	G-II-2	10 382-10 714 (27)
Industrial Development	18 0070	Clerk, Minister's Office (c)	C-II-2	10 482-10 797
Industrial Development	18 0457	Regional Officer Geraldton, Decentralisation Section, Industries Branch, Division of Industries (c)	C-II-5	12 573-12 938
Industrial Development	18 0520	Research Officer Grade 2, Research Branch, Division of Industries (28)	C-II-5/6	12 573-13 715
Labour and Industry	19 1040	Research Officer, Industrial Registrar's Office	C-II-5/6	12 573-13 715
Labour and Industry	19 1330	Clerk, Industrial Training Branch	C-II-1	9 847-10 165
Lands and Surveys	20 2285	Clerk, Clerical Section Accounts Branch	C-II-1	9 874-10 165
Metropolitan Water Board	22 1330	Clerk, Relieving Staff Section, Services Branch, Accounting Division (c)	C-II-3	11 142-11 483
Metropolitan Water Board	22 5950	Engineering Assistant Grade 3, Electrical Section, Mechanical and Electrical Branch, Engineering Division (29)	G-II-2/3	10 382-11 397
Mines	23 2426	Engineer, Drilling Section, State Mining Engineer Branch, (a) (31) (33)	Level 1 OR Level 2	10 833-14 481 OR 15 396-16 825
Mines	23 2475	Technical Officer, Drilling Section, State Mining Engineer Branch (a) (33) (36)	G-II-2/3	10 382-11 397
Public Health	08 4926	General Assistant, Microbiology Section, State Health Laboratories (a) (42)	G-VII-2/3	8 642-9 439
Public Health	08 9266	Tutor Dental Therapist, School of Dental Therapy, Dental Health Service (43)	G-I	10 063-11 397
Public Health	08 9324	Clerk, Clerical Section, Dental Health Service	C-II-1	9 847-10 165
Public Works	29 1610	Clerk, Revenue Branch, Accounts Division (c)	C-II-2	10 482-10 797
Public Works	29 3281	Engineering Surveyor Grade 2, Survey Research and Ground Engineering Section, Planning Design and Investigation Branch, Engineering Division (a) (44) (45)	Level 1	10 448-13 201
Public Works	29 7601	Architect In Charge, Specifications Section, Services Branch, Architectura' Division	Level 3	17 698-19 880
Public Works	29 8183	Supervisor, Relieving Staff Section, Construction and Maintenance Branch, Architectural Division (a) (46) (48)	G-II-4/5	11 753-12 842
Public Works	29 8360	Drafting Assistant, Design Section, Mechanical Engineering Design and Construction Branch, Architectural Division (a) (49)	G-XI	3 987-10 714
Public Works	29 8955	Structural Engineer, Executive Section, Structures Engineering Design and Construction Branch, Architectural Division	Level 4	20 860-22 027
Road Traffic Authority	40 0710	Clerk, Services Section, Vehicle Records Branch, Clerical Division (c)	C-II-1	9 847-10 165
Road Traffic Authority	40 2310	Cashier, Boulder Branch Office	C-II-1	9 847-10 165
Road Traffic Authority	40 4065	Clerk—Data Preparation, Data Preparation Section, Accounts Division	C-II-1	9 847-10 165
Road Traffic Authority	40 4340	Supervisor, Automatic Data Processing Centre, Accounts Division	C-III-3	9 560-9 778
Road Traffic Authority	40 5362	Clerk, Vehicle Examination Section, Examination and Technical Services Division	C-II-1	9 847-10 165
Road Traffic Authority	40 5488	Relieving Examiner Examination Section, Examination and Technical Services Division (a) (50) (51) (52)	G-II-1	9 743-10 063
State Government Insurance Office	31 5035	Clerk Certifying, Accounts and Policies Branch (c)	C-II-3	11 142-11 483
State Housing Commission	32 1655	Collector, North Centra' Section, Country Branch, Housing Division (c)	C-II-1	9 847-10 165
State Housing Commission	32 6620	Area Supervisor Aboriginal Housing, Supervision	G-II-5/6	12 475-13 631

VACANCIES IN THE PUBLIC SERVICE—*continued*

Department	Item No.	Position	Classn.	Salary
<b>Closing May 5, 1978</b>				\$
State Housing Commission	32 6990	Section, Architectural Branch, Development Operations Division (a)		
		A.D.P. Manager, Automatic Data Processing Branch, Corporate Services Division (a) (53)	A-I-1	18 912
State Taxation	33 1007	Senior Clerk, Assessing Section, Land Tax Division	C-II-4	11 842-12 209
Tourism	27 3770	Tourist Officer, Tours and Services Section, Perth Travel Centre (c)	C-II-1	9 847-10 165
Town Planning	34 0310	Senior Planning Officer, Statutory Planning and Property Branch (a) (54)	Level 4	\$22 703
Treasury	35 0095	Research Officer Grade 1, Financial Policy and Research Branch (c) (55)	C-II-8	15 270-15 657
Treasury	36 0045	Typist, Administrative Division, Government Stores Department	C-III-1	8 672
<b>Closing May 12, 1978</b>				
Community Welfare	10 3256	Occupational Therapist, Institutional Services Division (a) (1) (9)	Level 1	10 448-14 481
Community Welfare	10 3266	Occupational Therapist, Institutional Services Division (a) (1) (10)	Level 1	10 448-14 481
Education	14 3777	Workshop Supervisor, Clerical Branch, Technical Education Division (a) (11) (13)	G-II-4	11 753-12 118
Education	14 4372	Laboratory Manager, Mt. Lawley Technical College, Technical Education Division (a) (14)	G-II-6/7	13 247-14 083
Forests	17 1930	Computer Operator, Computer Services Section, Accounts Branch (15)	C-II-1	9 847-10 165
Labour and Industry	19 1205	Secretary Promotions Appeal Board, Public Service Arbitrator's Office	C-II-2	10 482-10 797
Medical	07 0151	Communications Officer, Communications Section, Planning Maintenance and Supply Branch (a) (16) (17) (19)	G-II-2/3	10 382-11 397
Public Works	29 0131	Clerk, Staff Section (c)	C-II-1	9 847-10 165
State Housing Commission	32 0630	Clerk, Field Section, Collections Branch, Housing Division (c)	C-II-1	9 847-10 165
State Housing Commission	32 1170	Clerk/Collector, South West Section, Country Branch, Housing Division (c)	C-II-1/2	9 847-10 797
State Taxation	33 2100	Typist, Assessing Section, Stamp Duties Division	C-III-1	8 672
Tourism	27 4040	Tourist Officer, Melbourne Travel Centre (c)	C-II-1	9 847-10 165 (20)
Treasury	35 0295	Senior Administrative Officer, General Finance Branch, Administrative Division (c)	A-I-3	20 607
Treasury	36 1465	Clerk, Accounts Branch, Government Stores Department	C-II-1	9 847-10 165

The possession of, or progress towards, an appropriate tertiary level academic qualification will be considered a factor, increasing in importance with the level of classification, when determining efficiency of applicants in the Clerical Division.

(a) Applications also called outside the Service under section 24.

(b) The promotion will date from the first working day following the retirement of the present occupant.

(c) Appointment to this position is conditional on the item being vacated by the present occupant.

(1) Eligibility for registration with the W.A. Occupational Therapists Board.

(2) Achievement Certificate with intermediate passes in English, Science, Social Studies, ordinary pass in Mathematics and pass in one other subject or equivalent qualifications.

Preference for Certificate of Secondary Education, Diploma of a recognised agricultural college or Certificate in Applied Science (T.E.D.).

(3) LOCATION: South Perth.

(4) Achievement Certificate with Intermediate passes in English, Science, Social Studies, Ordinary pass in Maths and pass in one other subject. Preference for Certificate of Secondary Education or Diploma of a recognised Agricultural College. Allowance paid for Diploma.

(5) LOCATION: South Perth with travel to the country as required.

(6) Master of Psychology (Clinical) degree from the University of Western Australia or qualifications deemed equivalent.

(7) A current driver's licence is essential.

(8) University degree or equivalent. Preference will be given to applicants with knowledge in the fields of mining, industry and natural science.

(9) Longmore Remand and Assessment Centre, Bentley.

(10) Nyandi Treatment and Research Centre, Bentley.

(11) An experienced engineering tradesman with progress towards a TED diploma in an appropriate area of study or an approved equivalent plus experience in the supervision of staff.

(12) After initial training in Perth the officer will be posted in Karratha where he will be provided with Government rental accommodation but will be expected to travel extensively in the Pilbara region.

(13) LOCATION: Maintenance Workshop and Stores, Balga.

(14) Diploma in Applied Science or approved equivalent. Progress towards a higher qualification will be an advantage. Applicants must be experienced in the servicing and construction of laboratory apparatus and will be expected to show evidence of administrative ability.

(15) Knowledge of Inter Data 7/32 working in Real Time, On Line mode an advantage. Applicants should have some experience in COBOL programming.

(16) Experience in the planning and administration of communications systems (telephone, telex, paging and radio) for industry or Government.

(17) Current driver's licence essential.

(18) A current driver's licence essential. Government vehicle provided for use on official business.

(19) LOCATION: Perth with a requirement to make field trips throughout the State.

(20) Interstate Allowance—\$400 p.a. married officer, \$200 p.a. single officer, Supplementary Allowance \$500 p.a.

(22) Plus district allowance of \$1 555 (married rate), where applicable, or \$777 (single rate).

VACANCIES IN THE PUBLIC SERVICE—*continued*

- (23) Eligibility for membership of the Australian Association of Speech and Hearing. Previous experience of working with children an advantage.
- (25) Progress towards a Diploma in Architectural Drafting, Building or Structural Engineering or approved equivalent. Trade qualifications and/or other relevant experience would be an advantage.
- (27) Plus 15 per cent Overtime Allowance normally 30 per cent whilst at Sea.
- (28) Preference for applicants with a Degree in Economics, Commerce or Arts (Economics).
- (29) Progress towards a relevant Diploma in Engineering (4 or 5 units) or approved equivalent academic qualification with at least 2 years' relevant experience; OR 8 years' relevant experience.
- (31) A degree or diploma in electrical and mechanical engineering, acceptable for corporate membership of the Institution of Engineers, Australia.  
Varied experience including preferably 3 years in the electronic engineering field. Some field work with high resolution analogue and digital recording systems would be an advantage.
- (33) LOCATION: Based in Perth at the Drill Store, Carlisle. Visits to field jobs located anywhere in W.A. are necessary.
- (36) A recognised diploma in electronics or equivalent qualifications. A current driving licence covering rigid trucks. At least 2 years sound practical experience in electronic servicing.
- (42) Experience in a laboratory organization preferable.
- (43) Applicants must have completed at least two years' service as a qualified Dental Therapist and show evidence of participation in career development training courses conducted by the Dental Health Service.
- (44) Diploma in Engineering Surveying from the Technical Education Division or approved equivalent. Minimum of one years practical surveying experience.
- (45) LOCATION: Initially in Perth, but will be required to undertake survey duties anywhere within W.A. Camp allowance and travelling allowance as appropriate are payable during absences from headquarters.
- (46) Possess a sound knowledge of good building practices. Preference for a Builder's Registration Certificate.
- (48) Must be prepared to serve anywhere in the State including a term of up to four years in the North West.
- (49) Achievement Certificate (or equivalent) including English, Social Studies and Science at Intermediate level and Maths at Ordinary level, plus a drawing orientated subject.  
In addition to the above, applicants 21 years of age and over must have a minimum of 2 years appropriate drawing office experience.  
Relevant trade experience or lengthy drawing office experience will also be considered in lieu of formal qualifications.
- (50) Qualified in the trade as a Motor Mechanic and preference to holders of several classes of Motor Driver's Licence.
- (51) Hours of duty normally 8.00 a.m. to 4.15 p.m., Monday to Friday.
- (52) Located in the Metropolitan Area with relieving at other centres throughout the State.
- (53) Knowledge of "Data-Base" and "on-line" systems techniques is essential.
- (54) Recognised degree in Town and Regional Planning for admission as a member of The Royal Australian Planning Institute or its equivalent. Wide experience in town planning, including development control at a senior level, preferably with experience and/or qualifications in valuation and property management.
- (55) Degree or equivalent in Economics, Commerce or Arts (Economics).
- (57) Post graduate qualifications in one of the Social Sciences, plus experience in institutional administration.

Applications are called under section 34 of the Public Service Act, 1904-1975, and are to be addressed to the Chairman, Public Service Board, and should be made on the prescribed form, obtainable from the offices of the various Permanent Heads of Departments.

G. H. COOPER,  
Chairman, Public Service Board.

28th April, 1978.

## Public Service Arbitration Act, 1966-1977

STATE PUBLIC SERVICE  
DETERMINATION—GEOLOGISTS

PURSUANT to Section 12 of the Public Service Arbitration Act, 1966-77, the Public Service Board hereby gives notice that the titles, salaries or salary ranges allocated to offices and salary within each salary range allocated to officers covered by the Public Service Professional Division (Geologists) Salaries Agreement 1978, No. 5 of 1978, as at November 29, 1977, shall be in accordance with the following determination.

## DEPARTMENT OF MINES

Item No.	Title of Office	Name of Office	Classification		Salary Excluding Allowances
			28/11/77	29/11/77	
PETROLEUM TECHNOLOGY					
23 2550	Reservoir Engineer	Vacant	4	4	....
23 2580	Production Geologist	Smith, D. N.	4	4	20 421
GEOLOGICAL SURVEY					
23 4780	Director	Lord, J. H.	8	8	29 790
23 4790	Deputy Director	Trendall, A. F.	7	7	24 542
23 4800	Geophysicist	Rowston, D. L.	4	4	21 570
23 4805	Petrologist	Vacant	4	4	....
23 4810	Palaentologist	Cockbain, A. E.	4	4	21 570
23 4815	Geophysicist	Megallaa, M. N.	3	3	19 455
23 4821	Geochemist	Davy, R.	4	4	21 570
23 4822	Geophysicist	Nowak, I. R.	2	2	16 445
23 4823	Geologist	Biggs, E. R.	2	2	16 445
23 4824	Geologist	Lewis, J. D.	2	2	16 445
23 4825	Geologist	Backhouse, J.	2	2	16 033
23 4826	Geologist	Archer, R. H.	1	1	14 136
23 4827	Geologist	Grey, K.	1	1	14 136
23 4828	Geologist	Vacant	2	2	....
23 4830	Geologist	Cameron, J. F.	1	1	12 875
23 4835	Geologist	Blight, D. F.	1	1	12 875
23 4840	Geologist	Green, K. H.	1	1	14 136
23 4841	Geologist	Williams, S. J.	1	1	12 875
23 4842	Geologist	Wenham, M. E.	1	1	14 136
23 4843	Geologist	Connolly, R. R.	2	2	16 445



## DEPARTMENT OF MINES

Item No.	Title of Office	Name of Officer	Classification		Salary Excluding Allowances
			28/11/77	29/11/77	
HYDROGEOLOGY AND ENGINEERING GEOLOGY					
					\$
23 5150	Chief Hydro Geologist	O'Driscoll, E. P. D.	6	6	23 066
23 5153	Supervising Geologist	Mather, R. P.	5	5	22 236
23 5155	Supervising Geologist	Bestow, T. T.	5	5	22 236
23 5160	Senior Geologist	Laws, A. T.	3	3	17 305
23 5165	Senior Geologist	Allen, A. D.	3	3	19 455
23 5180	Geologist	Marcos, G. W. A.	2	2	16 445
23 5185	Geologist	Davidson, W. A.	2	2	16 445
23 5187	Geologist	Harley, A. S.	2	2	15 396
23 5190	Geologist	Briese, E. H.	1	1	14 136
23 5200	Geologist	Moncrieff, J. B.	1	1	11 672
23 5210	Geologist	Barnett, J. C.	2	2	16 033
23 5220	Geologist	Lewis, I. H.	1	1	12 875
23 5225	Geologist	Klenowski, G.	1	1	12 875
23 5230	Geologist	Commander, D. P.	1	1	14 136
23 5240	Geologist	Furness, L. J.	1	1	11 672
23 5250	Geologist	Wharton, P.	1	1	12 328
23 5255	Geologist	Leech, R. E. J.	1	1	14 136
SEDIMENTARY OIL					
23 5340	Supervising Geologist	Playford, P. E.	5	5	22 236
23 5345	Senior Geologist	Vacant	4	4	....
23 5346	Senior Geologist	Crank, K. A.	3	3	19 455
23 5350	Geologist	Denham, P. D.	2	2	16 445
23 5360	Geologist	Vacant	1	1	....
23 5365	Geologist	Hocking, R. M.	1	1	12 328
23 5370	Geologist	Butcher, B. P.	1	1	12 328
REGIONAL GEOLOGY					
23 5460	Supervising Geologist	Gee, R. D.	5	5	22 236
23 5470	Senior Geologist	Williams, I. R.	3	3	19 455
23 5485	Geologist	Muhling, P.	2	2	16 445
23 5490	Geologist	Elias, M.	1	1	12 875
23 5500	Geologist	Bunting, J. A.	2	2	15 396
23 5510	Geologist	Thom, R.	1	1	14 136
23 5515	Geologist	Brakel, A. T.	1	1	14 136
23 5520	Geologist	Chin, R. J.	1	1	13 451
MINERAL RESOURCES					
23 5620	Supervising Geologist	Clockley, J. G.	5	5	22 236
23 5630	Senior Geologist	Marston, R. J.	3	3	17 912
23 5635	Senior Geologist Evaluation	Carter, J. D.	3	3	19 455
23 5640	Geologist	Baxter, J. L.	2	2	16 445
23 5645	Geologist	Morrison, R. J.	2	2	16 033
23 5650	Geologist	Hickman, A. H.	2	2	15 396
23 5655	Geologist	Wilde, S. A.	2	2	15 396
23 5660	Geologist	Lipple, S. L.	1	1	14 136
23 5665	Geologist	Hill, W. B.	2	2	16 033

Crown Law Department,  
Perth, 28th April, 1978.

Ref: CLD. 3030/77.

IT is hereby notified for public information that His Excellency the Governor in Executive Council has approved of the following appointments to the Commission of the Peace for the State of Western Australia:—

Noel Leslie Muir of Lot 15, Price Street, Kulin.  
Raymond Leith Ross Viner of 54 Urch Street, Geraldton.

R. M. CHRISTIE,  
Under Secretary for Law.

Henry John deBurgh, 46 Rockton Road,  
Nedlands.

Colin Clement Parks, 77 Lyrebird Way,  
Langford.

Leslie Standish, 8 Doyle Court, Greenwood.

R. M. CHRISTIE,  
Under Secretary for Law.

Chief Secretary's Office,  
Perth, 9th April, 1978.

Crown Law Department,  
Perth, 28th April, 1978.

CLD 3030/77.

IT is hereby notified for public information that His Excellency the Governor in Executive Council has approved of the following appointments to the Commission of the Peace for the State of Western Australia:—

Stewart Francis Pedley, 11 Clive Street,  
Katanning.

THE Hon. Chief Secretary has approved the appointment of the following persons as Commissioners for Declarations under the Declarations and Attestations Act, 1913-1972:—

Curgenven, Phillip James—Lesmurdie.  
Curtis, Charles—Lesmurdie.  
Gust, Charles Ernest—Coogee.  
Webster, Colin Charles—Nollamara.

W. J. KIDSTON,  
Secretary.

## SUPREME COURT ACT, 1935.

Appointment of Commissioners for Affidavits.

Supreme Court Office,  
Perth, 26th April, 1978.

HIS Honour the Chief Justice has been pleased to appoint the following persons to be commissioners for affidavits:—

McPhee, Michael John; Cottesloe, W.A.  
Rattigan, Peter John; Fremantle, W.A.  
Meyer, Jonathan; Mosman Park, W.A.  
Hasluck, Nicholas Paul; Claremont, W.A.  
Hacket, Jeanette Anne; Mt. Pleasant, W.A.  
Forkin, Frank Joseph; Attadale, W.A.  
D'Angelo, John Nicholas; Scarborough, W.A.  
Clark, Philip Marcus; Mosman, N.S.W.  
Scott, Stephen George; West Leederville, W.A.  
Johnson, Richard Charles; Hamersley, W.A.  
Harkins, Brian O'Dennell; West Leederville, W.A.  
Taylor, Godfrey Edward; West Leederville, W.A.  
Wheatley, Richard James; South Perth, W.A.  
MacDonald, James Halbert Stuart; Kelmscott, W.A.

G. T. STAPLES,  
Registrar.

## HEALTH ACT, 1911-1976.

Department of Public Health,  
Perth, 19th April, 1978.

PHD. 891/60.

THE appointment of Mr. R. L. Mitchell as Relieving Health Surveyor to the Shire of Nannup during absences of Mr. B. Davey is approved.

J. C. McNULTY,  
Commissioner of Public Health  
and Medical Services.

## HEALTH ACT, 1911-1976.

Department of Public Health,  
Perth, 19th April, 1978.

PHD. 222/61.

THE cancellation of the appointment of Mr. W. G. C. Poole as Health Surveyor to the City of Subiaco is hereby notified.

J. C. McNULTY,  
Commissioner of Public Health  
and Medical Services.

THE PHARMACEUTICAL COUNCIL OF  
WESTERN AUSTRALIA.

(Regulation 14 Pharmacy Act Regulations, 1976.)

THE following persons have been elected members of the Pharmaceutical Council of Western Australia:—

John James Greig, Forrest Place Pharmacy,  
28 Forrest Place, Perth.  
Carmelo Manera, 332 Cambridge Street,  
Wembley.  
John Michael O'Hara, 39 Haynes Street, Kalamunda.  
President, Neil Joseph Geneve, Cloisters Square  
Pharmacy, 861 Hay Street, Perth.  
Deputy President, Gladys Anne Heedes, 57  
Grantham Street, Wembley.

E. P. WALSH,  
Registrar.

## POLICE ACT, 1892-1902.

THE following forfeited property will be sold by public auction at the Property Tracing Section, Police Complex, Swan Bank Road Maylands, on Tuesday, 16th May, 1978, commencing at 10.00 a.m.

10 698 bottles of imported German white wines.

## CONDITIONS OF SALE.

1. The highest bidder shall be the purchaser.
2. The Vendor shall have the right to bid by the Auctioneer or by the Vendor's Agent for any lot offered.
3. The Auctioneer may, without giving any reason therefor refuse to accept the bid of any person or persons and may decline the offer for any lot or withdraw any lot or lots from sale.
4. Should any dispute arise as to any bid, the relevant lot or lots may at the option of the Auctioneer be put up again and resold.
5. No allowance or refunds will be made nor will any buyer be permitted to reject any lot on the ground that it is not correctly described; the said lots are to be taken with all faults (if any) and will be at the Buyer's risk on the fall of the hammer.
6. All goods which have been paid for in full must be removed by the Purchaser at the Purchaser's expense by the close of the sale.
7. Time shall be the essence of the sale of any Lot.
8. Whilst every care has been taken in describing the goods offered for sale the Auctioneers and/or Vendors accept NO RESPONSIBILITY for any misdescription and make no warranty whatsoever.  
Measurements and quantities shown are approximate and intended only as a guide to prospective purchasers.
9. Payment strictly on the fall of the hammer.

## FORFEITURES.

THE following leases and licenses together with all rights, title and interest therein have this day been forfeited to the Crown under the Land Act, 1933-1977, for the reasons stated:—

Name; Lease or License; District Reason;  
Corres. No.; Plan.

McKinnon, A. L. A., Thomas, R. A.; 338/13300;  
Gracetown Lot 147; Non-compliance with  
conditions; 3218/75; Townsite.

The Public Trustee as Administrator of the Estate  
of Christopher James Turle; 347/10787; Old-  
field Location 637; Non-compliance with con-  
ditions; 1165/55; 420BB/20.

F. W. BYFIELD,  
Under Secretary for Lands.

## LAND ACT, 1933-1977.

Land Release.

Department of Lands and Surveys,  
Perth, 28th April, 1978.

File No. 2335/65.

HIS Excellency the Governor in Executive Council has been pleased to approve under section 45A of the Land Act, 1933-1977, of Cervantes lot 9 being made available for sale in fee simple at the purchase price of one thousand dollars (\$1 000) and subject to the payment for improvements at valuation, in cash, should the successful applicant be other than the former lessee.

Applications must be lodged at the Department of Lands and Surveys, Perth.

(Plan Cervantes 05.25 (Catalonia Street).)

F. W. BYFIELD,  
Under Secretary for Lands.

## LAND ACT, 1933-1977.

## Land Release.

Department of Lands and Surveys,  
Perth, 28th April, 1978.

File No. 1327/63.

HIS Excellency the Governor in Executive Council has been pleased to approve under section 45A of the Land Act, 1933-1977, of Mount Magnet Lot 98 being made available for sale in fee simple at the purchase price of two hundred dollars (\$200) and subject to the payment for improvements at valuation, in cash, should the successful applicant be other than the former lessee.

Applications must be lodged at the Department of Lands and Surveys, Perth.

(Plan Mount Magnet Townsite (Naughton Street).)

F. W. BYFIELD,  
Under Secretary for Lands.

Department of Lands and Surveys,  
Perth, 28th April, 1978.

IT is hereby notified for general information that the Land Board has determined that the following applications for land shall be granted:—

Yilgarn Locations situated 41 kilometres north-east of Mukinbudin.

Yilgarn Location 1499 containing 484 hectares to John Bennett and Janet Ruth Bennett both c/- P.O. Burracoppin W.A.

Yilgarn Location 1500 containing 2 699 hectares to Walter Herbert Geier c/- P.O. Box 415 Merredin W.A.

Yilgarn Location 1501 containing 3 367 hectares to Richard McMillan Brown, William McMillan Brown and James McMillan Brown (discharged member of the forces) all c/- P.O. Box 107 Merredin W.A.

Jilbadji District an unsurveyed area of about 2 150 hectares situated 44 kilometres southeast of Bodallin to Mario Borona, Phillip Mervyn Borona and Garry James Borona all c/- P.O. Moorine Rock W.A.

F. W. BYFIELD,  
Under Secretary for Lands.

## LOCAL GOVERNMENT ACT, 1960-1977.

Department of Lands and Surveys,  
Perth, 28th April, 1978.

IT is hereby declared that, pursuant to the resolution of the Shire of Albany, passed at a meeting of the Council held on or about March 1, 1968, the undermentioned lands have been set apart, taken, or resumed under section 17 of the Public Works Act, 1902, for the purpose of a new road, that is to say:—

Albany.

820/68 (R5641).

Road No. 15508 (Warriup Road) (Extension of Part) A strip of land, varying in width commencing at the eastern terminus of the present road at the eastern boundary of Plantagenet Location 3886 (Reserve No. 16367) and extending as delineated and coloured dark brown on Original Plans 13498 and 13499 generally northeastward through Location 3857 and 1071 to terminate at the western side of a surveyed road at the eastern boundary of the lastmentioned Location and at the easternmost boundary of Location 3857.

12.817 9 hectares being resumed from Plantagenet Location 3857.

474 square metres being resumed from Plantagenet Location 1071.

(Public Plan 450/80).

IT is hereby declared that, pursuant to the resolution of the Shire of Collie, passed at a meeting of the Council held on or about February 10, 1977, the undermentioned lands have been set apart, taken, or resumed under section 17 of the Public Works Act, 1902, for the purpose of a new road, that is to say:—

Collie.

723/45 (R5614).

Road No. 15983 (Don Road) A strip of land 20 metres wide commencing at the northeastern side of Road No. 10379 (Coalfields Road) at the southwestern boundary of the most northeastern severance of Wellington Location 2658 and extending as delineated and coloured dark brown on Lands and Surveys Diagram 82485, generally north-eastward through that severance to terminate at the northern boundary of the said severance.

9 727 square metres being resumed from Wellington Location 2658.

(Public Plan Muja S.W. 1:25 000).

IT is hereby declared that, pursuant to the resolution of the Shire of Koorda, passed at a meeting of the Council held on or about September 27, 1976, the undermentioned lands have been set apart, taken, or resumed under section 17 of the Public Works Act, 1902, for the purpose of a new road, that is to say:—

Koorda.

428/14 (R5607).

Road No. 5151 (Deviation of Part) A strip of land, varying in width, leaving the southeastern side of the present road at the northwestern boundary of Ninghan Location 177 and extending as delineated and coloured dark brown on Lands and Surveys Diagram 82660 generally southeastward through that Location to terminate at the western side of Road No. 4891 at the eastern boundary of the said Location.

1 333 3 hectares being resumed from Ninghan Location 177.

(Public Plan 56/80).

IT is hereby declared that, pursuant to the resolution of the Shire of Roebourne, passed at a meeting of the Council held on or about April 24, 1974 and May 28, 1975, the undermentioned lands have been set apart, taken, or resumed under section 17 of the Public Works Act, 1902, for the purpose of a new road, that is to say:—

Roebourne.

2896/72 (MR1097) MRD 690/72.

Road No. 15863 (North West Coastal Highway) A strip of land varying in width, commencing within Reserve No. 611 as shown on Original Plan 13945 and extending as delineated and coloured mid and dark brown on Original Plans 13945, 13941, 13942, 13944 and 13943 as surveyed westward through Reserve No. 611 thence generally northwestward through Roebourne lot 390 and portion of lot 451 (Reserve No. 31446), vacant Crown land, and again through lot 451 (Reserve No. 31446) and vacant Crown land, portion of lot 300 (Reserve No. 1718), vacant Crown land and through lot 471 and again through vacant Crown land, thence through lots 200 to 206 (inclusive), 210 to 214 (inclusive) 216 to 220 (inclusive) 351 to 357 (inclusive) (Reserve No. 12071), 86 and 87 (Reserve No. 12071), 361 and 82 to 85 (inclusive) thence through vacant Crown land to terminate at the southwestern side of North West Coastal Highway as shown on Original Plan 13943.

Road No. 15864 (Jiwuna Way) A strip of land, varying in width commencing at the northern side of Road No. 15863 within Roebourne lot 451 (Reserve No. 31446) and extending as delineated and coloured dark and mid brown on Original Plan 13941 generally northward through the said lot and vacant Crown land to terminate at the southern boundary of Kudjuna Way.

Road No. 15060 (Carnarvon Terrace) (i) (Extension) A strip of land 20.12 metres wide, commencing at the southern terminus of the present road, at a line in prolongation eastward of the southern boundary of Roebourne lot 10 and extending as surveyed southwestward to and along the southeastern boundary of lot 11 to and along portion of the southeastern boundaries of lot 317 (Reserve No. 1867) to terminate at the southeastern side of Road No. 15863.

(ii) (Widening of Parts) Those portions of Crown land as delineated and coloured dark brown on Original Plans 13942 and 13946.

Road No. 15865 A strip of land, varying in width, commencing at the northeastern side of Road No. 15863 within vacant Crown land and extending as delineated and coloured mid brown on Original Plan 13943 northeastward through vacant Crown land to terminate as shown on the said plan.

Those portions of Prince Street, Victoria Street, Carnarvon Terrace, Hampton Street, Stephen Street, Church Street, and Charles Street are hereby superseded.

Reserve Nos. 611, 31446, 1718, 1867 and 12071 are hereby reduced by 7.718 4 hectares, 1.886 8 hectares, 277 square metres, 1 114 square metres and 1.119 0 hectares respectively.

5 727 square metres being resumed from Roebourne Lot 471.

The whole of Roebourne Lot 219 is hereby resumed (2 023 square metres).

The whole of Roebourne Lot 217 is hereby resumed (2 022 square metres).

The whole of Roebourne Lot 352 is hereby resumed (2 023 square metres).

The whole of Roebourne Lot 353 is hereby resumed (2 023 square metres).

The whole of Roebourne Lot 354 is hereby resumed (2 023 square metres).

The whole of Roebourne Lot 355 is hereby resumed (2 024 square metres).

The whole of Roebourne Lot 356 is hereby resumed (2 023 square metres).

179 square metres being resumed from Roebourne Lot 351.

135 square metres being resumed from Roebourne Lot 357.

740 square metres being resumed from Roebourne Lot 86.

(Notice of intention to Resume gazetted October 28, 1977.) (Public Plans Roebourne 1:25 000 NE. 9.22 9.23, 9.24, 10.23, 10.24.)

IT is hereby declared that, pursuant to the resolution of the Shire of Williams, passed at a meeting of the Council held on or about February 4, 1977, the undermentioned lands have been set apart, taken, or resumed under section 17 of the Public Works Act, 1902, for the purpose of a new road, that is to say:—

Williams.

1192/76 (R5643).

Road No. 11965 (Medlans Road) (i) (Extension) A strip of land, varying in width, commencing at the eastern terminus of the present road at the eastern boundary of Williams location 11674 and extending as surveyed, northeastward through location 14931 thence northward along portion of the western boundary of location 13000 thence eastward along portion of the northern boundary of the lastmentioned location thence generally northeastward through location 5301 to terminate at the eastern boundary of that location.

(ii) (Deviation of Part) A strip of land, varying in width leaving the eastern side of the present road at the western boundary of Williams location 13000 and extending as delineated and coloured dark brown on Lands and Surveys Diagram 82682 generally northeastward through that location to rejoin the southern and southeastern sides of the present road within the said location.

9 999 square metres being resumed from Williams location 13000.

(Public Plan Williams SE 1:25 000 NE 1:25 000.)

And whereas His Excellency the Governor has declared that the said lands have been set apart, taken, or resumed for the purpose of the said roads, and that plans of the said lands might be inspected at the Department of Lands and Surveys, Perth, it is hereby notified that the lands described above are roads within the meaning of the Local Government Act, 1960, subject to the provisions of the said Act.

By Order of His Excellency,

Dated this 12th day of April, 1978.

JUNE CRAIG,  
Minister for Lands.

#### CORRIGENDUM.

Department of Lands and Surveys,  
Perth, 28th April, 1978.

Lands and Surveys File 1879/34V2; Forrests File 800/62.

IN the notice appearing at page 841 of the *Government Gazette* dated 23rd March, 1978 relating to the amendment of State Forest No. 51 for "about 448 hectares" read "about 495 hectares".

F. W. BYFIELD,  
Under Secretary for Lands.

#### BUSH FIRES ACT, 1954.

Esperance Shire Council.

Harvesting Bans.

PURSUANT to the powers contained in Regulation 38C of the Regulations to the Bush Fires Act, it is hereby declared that the provisions of Regulation 38C prohibiting harvesting on Sundays and public holidays shall not apply in the Shire of Esperance on Sundays and the following public holidays:—

Boxing Day, Australia Day, Labour Day, Good Friday, Easter Monday, Anzac Day, the birthday of the reigning Sovereign and any other day proclaimed to be a public holiday throughout the State, or proclaimed to be a public holiday in the Shire of Esperance whether in addition to or in substitution for any of the public holidays specified in this notice.

By Order of the Council,

E. L. CHOWN,  
Shire Clerk.

#### TOWN PLANNING AND DEVELOPMENT ACT, 1928 (AS AMENDED).

Notice that a Town Planning Scheme Amendment has been Prepared and is Available for Inspection. City of Melville Town Planning Scheme No. 2—Amendment No. 141.

T.P.B. 853/2/17/5 Pt. 141.

NOTICE is hereby given that the Council of the City of Melville in pursuance of its powers under the Town Planning and Development Act, 1928 (as amended) has prepared a Town Planning Scheme amendment for the purpose of amending the Scheme by:—

- (1) adding to the Scheme legend under "Special Business" the terminology "Home and Garden Showroom Centre" against which the letters "HGSC" shall be added;

- (2) inserting in the Use Class Table a new use class, "Home and Garden Show Room Centre" and showing it as being an "X" use (i.e. a prohibited use) in all zones with the exception of the "S" "Special Business" Zone where it will be an "AA" use (i.e. a use that is permitted with the approval of Council);
- (3) adding a new clause 1.55 (c) to the Scheme Text to define a "Home and Garden Show Room Centre";
- (4) adding a new subclause (10) to Clause 4.22—Off Street parking requirements of the Scheme Text to require that customer and employee parking in "Special Business" zones be provided as directed by Council;
- (5) adding a new clause 4.37 (1) to the Scheme Text to specify special conditions which will apply to development on Lot 500 of Swan Loc 73 North Lake Road, Myaree; and
- (6) rezoning Lot 500 of Swan Loc 73, North Lake Road, Myaree from "Local Shopping" to "Special Business—Home and Garden Show Room Centre".

All plans and documents setting out and explaining the amendment have been deposited at Council Offices, Almondbury Road, Ardross, and will be open for inspection without charge during the hours of 9 a.m. to 4 p.m. on all days of the week except Saturdays, Sundays and Public Holidays until and including the 26th May, 1978.

The plans and documents have also been deposited at the office of the Town Planning Department, Perth, and will similarly be open for inspection for the same period between the hours of 10 a.m. and 4 p.m.

Any person who desires to make a submission on the amendment should make the submission in writing in the form prescribed by the regulations and lodge it with the Town Clerk, City of Melville, P.O. Box 130, Applecross 6153, on or before the 26th May, 1978.

R. H. FARDON,  
Town Clerk.

TOWN PLANNING AND DEVELOPMENT ACT,  
1928 (AS AMENDED).

Notice that a Planning Scheme has been Prepared and is Available for Inspection.

Shire of Albany Town Planning Scheme No. 7—  
Staged Guided Development for Residential  
Development Zones.

T.P.B. 853/5/4/7 Vol. 1.

NOTICE is hereby given that the Albany Shire Council in pursuance of its powers under the Town Planning and Development Act, 1928 (as amended), has prepared a Planning Scheme with reference to an area situate wholly with the Shire of Albany and enclosed within the inner edge of red borders on plans now produced to the Council and marked and certified by the Shire Clerk under his hand dated the 16th December, 1976, as Scheme Area Maps (Sheets 1, 2, 3, 4) which maps form part of the Scheme;

for the purpose of—

- (a) setting aside land for future public use as reserves;
- (b) control of land development;
- (c) improvements to Streets;
- (d) improvements to drainage;
- (e) provision of reticulated water supply;
- (f) provision of reticulated sewerage and associated works.

All plans and documents setting out and explaining the Planning Scheme have been deposited at Council Offices, Chester Pass Road, Albany, and will be open for inspection without charge during

the hours of 9 a.m. to 4 p.m. on all days of the week except Saturdays, Sundays and Public Holidays, until and including the 28th July, 1978.

The maps and other documents have also been deposited at the office of the Town Planning Department, Perth, and will similarly be open for inspection for the same period between the hours of 10 a.m. and 4 p.m.

Any person who desires to make a submission on the Planning Scheme should make the submission in writing in the form prescribed by the regulations and lodge it with The Shire Clerk, Albany Shire Council, P.O. Box 809, Albany 6330, on or before the 28th July, 1978.

F. P. JAGO,  
Shire Clerk.

TOWN PLANNING AND DEVELOPMENT ACT,  
1928 (AS AMENDED).

Advertisement of Approved Town Planning  
Scheme Amendment.

Shire of Armadale-Kelmscott—Town Planning  
Scheme No. 1—Amendment No. 102.

T.P.B. 853/2/22/1 Pt. 102.

IT is hereby notified for public information, in accordance with section 7 of the Town Planning and Development Act, 1928 (as amended) that the Minister for Urban Development and Town Planning approved the Shire of Armadale-Kelmscott Town Planning Scheme Amendment on the 18th April, 1978, for the purpose of amending the Scheme Text as set out in the schedule annexed hereto.

S. V. PRIES,  
President.  
A. E. RASMUSSEN,  
Shire Clerk.

Schedule.

TOWN PLANNING AND DEVELOPMENT ACT,  
1928 (AS AMENDED).

Shire of Armadale-Kelmscott—Town Planning  
Scheme No. 1—Amendment No. 102.

RESOLVED that the Council, in pursuance of section 7 of the Town Planning and Development Act, 1928 (as amended), amend the above Town Planning Scheme by (1) including the following definitions where alphabetically appropriate in Clause 1.8 within its Scheme Text:—

"Retail Plant Nursery"—means land or buildings used for the purpose of propagating and growing plants and the retailing thereof on site in conjunction with domestic garden products and utilities, but excluding the sale or display of motorised garden implements, swimming pools, pre-fabricated garden buildings or bulk garden products.

"Garden Centre"—means land or buildings used for the sale and display of bulk garden products, motorised domestic garden implements and the display but not manufacture of pre-fabricated garden buildings and swimming pools.

"Facade"—means face of building towards open space or frontal/outward appearance.

"Rural Use"—means and includes agriculture, horticulture, viticulture, orchards, grazing, forestry, and free-range poultry production, but excludes piggeries, battery poultry production and horse riding schools.

(2) Including "Rural Industry" as an "A.A." use within Zone 16 "Rural" within Table No. 1 of its Scheme Text.

(3) Modifying zone category 7.B of C1. 3.2 of its Scheme Text to read "Retail Plant Nursery" instead of "Plant Nursery".

(4) Adding zone category 7.I "Garden Centre" within C1. 3.2 of its Scheme Text.

TOWN PLANNING AND DEVELOPMENT ACT,  
1928 (AS AMENDED).

Notice that a Town Planning Scheme Amendment has been Prepared and is Available for Inspection.

Shire of Busselton—Town Planning Scheme  
No. 1—Amendment No. 61.

T.P.B. 853/6/6/1 Pt. 61.

NOTICE is hereby given that the Busselton Shire Council in pursuance of its powers under the Town Planning and Development Act, 1928 (as amended) has prepared a Town Planning Scheme amendment for the purpose of adding a new section 31B to the Scheme Text to provide that Pt. Lot 5 of Sussex Location 187 and 637, Caves Road, Wilyabrup shall be a Special Use Zone—Tourist Village with the following permitted uses—Caravan Park, Rental Cabins, Camping area, Licensed Restaurant and Wine sales.

All plans and documents setting out and explaining the amendment have been deposited at Council offices, Prince Street, Busselton, and will be open for inspection without charge during the hours of 9 a.m. to 4 p.m. on all days of the week except Saturdays, Sundays and Public Holidays until and including the 9th June, 1978.

The plans and documents have also been deposited at the office of the Town Planning Department, Perth and will similarly be open for inspection for the same period between the hours of 10 a.m. and 4 p.m.

Any person who desires to make a submission on the amendment should make the submission in writing in the form prescribed by the regulations and lodge it with The Shire Clerk, Shire of Busselton, P.O. Box 84, Busselton 6280 on or before the 9th June, 1978.

P. S. HOLGATE,  
Shire Clerk.

TOWN PLANNING AND DEVELOPMENT ACT,  
1928 (AS AMENDED).

Advertisement of Approved Town Planning Scheme Amendment.

Shire of Esperance—Town Planning Scheme  
No. 16—Amendment No. 1.

T.P.B. 853/11/6/11 Pt. 1.

IT is hereby notified for public information, in accordance with section 7 of the Town Planning and Development Act, 1928 (as amended) that the Minister for Urban Development and Town Planning approved the Shire of Esperance Town Planning Scheme Amendment on the 11th April, 1978, for the purpose of rezoning part of Esperance East Location 21 from Recreation and Industrial to Residential and Recreation as depicted on the amending plan adopted by Council on the 28th June, 1977, and approved by the Minister for Urban Development and Town Planning.

W. S. PATERSON,  
President.

E. L. CHOWN,  
Shire Clerk.

TOWN PLANNING AND DEVELOPMENT ACT,  
1928 (AS AMENDED).

Shire of Laverton Interim Development Order  
No. 3.

T.P.B. 26/11/8/1.

NOTICE is hereby given that in accordance with the provisions of subsection (2) of section 7B of the Town Planning and Development Act, 1928 (as amended), and by direction of the Minister for Urban Development and Town Planning a summary as set out hereunder of the Laverton Shire Council Interim Development Order No. 3 made pursuant to the provisions of section 7B of that Act is published for general information.

The Minister for Urban Development and Town Planning has made copies of this Order available for inspection by any person free of charge at the offices of the Town Planning Board, Oakleigh Building, 22 St. George's Terrace Perth, and at the offices of the Laverton Shire Council during normal office hours.

## Summary.

1. The Shire of Laverton Interim Development Order No. 3 contains provisions *inter alia*—

- (a) That the Order applies to that part of the Shire of Laverton specified in the Order.
- (b) That, subject as therein stated, the Laverton Shire Council is the authority responsible for its administration.
- (c) That the carrying out of certain development on land within the scope of the Order without approval as stated therein is prohibited.
- (d) Relating to the application for, and grant of approval for, development other than development permitted by the Order.
- (e) Relating to development by a public authority.
- (f) Relating to certain development permitted by this Order.
- (g) Relating to the continuance of the lawful use of land and buildings.
- (h) Relating to appeals against refusal of approval for development or against conditions subject to which approval to carry out development is granted.

2. The Order has effect from and after the publication of this summary in the *Government Gazette*.

T. S. RULAND,  
Shire Clerk.

## PUBLIC WORKS DEPARTMENT

Tenders, closing at Perth at 2.30 p.m. on the dates mentioned hereunder are invited for the following works.

Tenders are to be addressed to "The Hon. Minister for Works, c/o Contract Office, Public Works Department, corner King's Park Road and Havelock Street, West Perth", and are to be endorsed "Tender".

The highest, lowest, or any tender will not necessarily be accepted.

Contract No.	Project	Closing Date	Conditions now Available at:
21136 ....	Derby Leprosarium—Fire and Water Service ....	2/5/78	P.W.D., West Perth P.W.D., A.D., Derby P.W.D., A.D., Kununurra P.W.D., A.D., Port Hedland P.W.D., West Perth
21106 ....	Sale by Public Tender of Bunbury Lot 87 and Bunbury Lot 438, Parry Street. Highest or any tender not necessarily accepted	2/5/78	P.W.D., West Perth
21147 ....	Community Welfare Department—H.F. S.S.B. Radio Link Kalgoorlie-Warburton Ranges	2/5/78	P.W.D., West Perth

PUBLIC WORKS DEPARTMENT—*continued*

Contract No.	Project	Closing Date	Conditions now Available at:
21148 ....	Dongara District Primary School—New Classrooms 1978— Electrical Installation	2/5/78	P.W.D., West Perth P.W.D., A.D., Geraldton Police Station, Dongara
21149 ....	Yakamia (Albany) Primary School—6 Classroom and Admini- stration Additions—Electrical Installation	2/5/78	P.W.D., West Perth P.W.D., A.D., Albany
21152 ....	North Maddington Primary School, Admin. and 8 Classrooms and Pre Primary Centre—Erection 1978	2/5/78	P.W.D., West Perth
21153 ....	Waddington (Koondoola) Primary School, Admin. and 8 Class- rooms and Pre Primary Centre—Erection 1978	2/5/78	P.W.D., West Perth
21154 ....	Oberthur (Bullcreek) Primary School, Admin. and 8 Classrooms and Pre Primary Centre—Erection 1978	2/5/78	P.W.D., West Perth
21155 ....	Grovelands (Kelmscott) Primary School, Admin. and 8 Class- rooms and Pre Primary Centre—Erection 1978	2/5/78	P.W.D., West Perth
21156 ....	Bunbury, Rural & Industries Bank—Alterations to Shop Front	2/5/78	P.W.D., West Perth P.W.D., A.D., Bunbury
21161 ....	Perth—Floor, Window and General Cleaning—Public Trust Building, 565 Hay Street	2/5/78	P.W.D., West Perth
21162π ....	The Queen Elizabeth II Medical Centre—Central Supervisory Data System (Direct Contract)	18/5/78	P.W.D., West Perth
21165 ....	Hedland Senior High School—Additions 1978—Fixed (Furniture Nominated Sub-Contract)	2/5/78	P.W.D., West Perth P.W.D. A.D., Pt. Hedland
21166 ....	Ferndale Primary School—Admin and 8 Classrooms and Pre Primary Centre—Erection 1978	2/5/78	P.W.D., West Perth
21167§ ....	Halls Creek Primary School—Upgrading—Air Conditioning and New Classrooms—Erection	9/5/78	P.W.D., West Perth P.W.D. A.D., Kununurra P.W.D. A.D., Pt. Hedland Police Station, Halls Creek
21168π ....	Narrogin Agricultural Senior High School—New Hall/Gym- nasium—Erection	2/5/78	P.W.D., West Perth P.W.D. A.D., Narrogin
21169* ....	The Queen Elizabeth II Medical Centre—Podium and Ward Block—Aluminium Windows Doc 7.2 4, 5, 6, 7 and 8 Floors	9/5/78	P.W.D., West Perth
21170‡ ....	The Queen Elizabeth II Medical Centre—Podium and Ward Block—Steelwork—Roof Doc 4.4	2/5/78	P.W.D., West Perth
21171‡ ....	The Queen Elizabeth II Medical Centre— Podium and Ward Block—Metal Deck Roofing Doc 6.1	9/5/78	P.W.D., West Perth
21172 ....	Donnybrook Water Supply High Level Area—A 225 m <sup>3</sup> R.C.C. Roofed Tank	2/5/78	P.W.D. West Perth
21173 ....	Katanning—Sewerage—Sewers in Reticulation Area No. 9 (Schedule of Rates)	9/5/78	P.W.D. West Perth
21174 ....	The Queen Elizabeth II Medical Centre—Registration of Tender- ers for the Podium and Ward Block Electrical Installation— Fourth-Ninth Floors inclusive	2/5/78	P.W.D. West Perth
21175 ....	Safety Bay High School Stage 2—Fixed Furniture (Nominated Sub Contract)	9/5/78	P.W.D. West Perth
21176 ....	Maddington High School Stage 2—Fixed Furniture (Nominated Sub Contract)	9/5/78	P.W.D. West Perth
21177 ....	East Beechboro Primary School—Admin and 8 classrooms and Pre Primary Centre—Erection 1978	9/5/78	P.W.D. West Perth
21178 ....	Carine Technical College—Aluminium Doors and Windows (Nominated Sub Contract)	‡4/5/78	P.W.D. West Perth
21180 ....	Bridgetown Hospital Nurses Quarters—External and part In- ternal Repairs and Renovations	9/5/78	P.W.D. West Perth P.W.D., A.D., Bunbury Clerk of Courts Bridgetown
21181 ....	Nannup Water Supply New Chemi-Feed Building—Erection ....	9/5/78	P.W.D. West Perth P.W.D., A.D., Bunbury Police Station, Nannup
21182 ....	Huntingdale Primary School Additions 1978—Electrical In- stallation	9/5/78	P.W.D. West Perth
21183 ....	Kardinya Primary School Additions 1978—Electrical Installation	9/5/78	P.W.D. West Perth
21184 ....	Waddington (Koondoola) Primary School Erection 1978— Electrical Installation (Nominated Sub Contract)	9/5/79	P.W.D. West Perth
21185 ....	Oberthur (Bullcreek) Primary School Erection 1978—Electrical Installation (Nominated Sub Contract)	9/5/78	P.W.D. West Perth
21186 ....	Safety Bay High School Stage 2, 1978—Electrical Services (Nom- inated Sub Contract)	9/5/78	P.W.D. West Perth
21187 ....	Sale by Public Tender of Ptn of North Fremantle Lot P52 being Lot 11 and 14 on Plan 794 in C/T Vol 221 Folio 119 Highest or any tender not necessarily accepted	2/5/78	P.W.D. West Perth
21189 ....	Maddington High School Stage 2, 1978—Electrical Services ....	9/5/78	P.W.D. West Perth
21190 ....	Royal Perth Hospital, Shenton Park, Stage 2—Electrical Devel- opment	2/5/78	P.W.D. West Perth
21179‡ ....	Carine Technical College Stage 1A—Mechanical Services	16/5/78	P.W.D., West Perth
21188 ....	Sale by Public Tender of Wellington Location 1 being Portion of Lot 14—Highest or any Tender not necessarily accepted	9/5/78	P.W.D., West Perth
21191 ....	Registration of Tenderers for Fremantle Hospital, South Terrace Additions—Ductwork—Pipework—Levels 7 to 9 Mech 36-1-4	2/5/78	P.W.D., West Perth
21192 ....	Pinnaroo Valley Memorial Park—Grounds Water Reticulation	9/5/78	P.W.D., West Perth
21193 ....	Waggrakine (Geraldton) Primary School Admin. and 8 Class- rooms and Pre-Primary Centre—Erection 1978	23/5/78	P.W.D., West Perth P.W.D., A.D., Geraldton
21194 ....	The Rural and Industries Bank of W.A., 101-103 St. George's Terrace, Perth—Alterations and Additions	16/5/78	P.W.D., West Perth
21195 ....	Osborne Park Hospital—New Access Road ....	9/5/78	P.W.D., West Perth
21196 ....	Narrogin Agricultural High School New Hall and Gymnasium— Electrical Services (Nominated Sub Contract)	16/5/78	P.W.D., West Perth P.W.D., A.D., Narrogin

PUBLIC WORKS DEPARTMENT—*continued.*

Contract No.	Project	Closing Date	Conditions now Available at:
21198 ....	Halls Creek Primary School—Additions 1978—Electrical Services (Nominated Sub Contract)	16/5/78	P.W.D., West Perth P.W.D., A.D., Port Hedland P.W.D., A.D., Derby P.W.D., A.D., Kununurra Police Station, Halls Creek P.W.D., West Perth
21199 ....	North Maddington Primary School—Erection 1978—Electrical Installation	16/5/78	P.W.D., West Perth
21200 ....	Grovelands Primary School—Erection 1978—Electrical Installation	16/5/78	P.W.D., West Perth
21201 ....	Hyden Water Supply—225 m <sup>3</sup> Reinforced Concrete Circular Roofed Tank	16/5/78	P.W.D., West Perth
21202 ....	Broome Hospital 8 Bed Ward Block—Incinerator and Transformer—Erection	23/5/78	P.W.D., West Perth P.W.D., A.D., Derby Clerk of Courts, Broome
21203 ....	Derby Hospital—New Theatre and C.S.S.D.—Erection	23/5/78	P.W.D., West Perth P.W.D., A.D., Derby P.W.D., A.D., Kununurra P.W.D., A.D., Port Hedland
21204‡‡	Fremantle Hospital, South Terrace Additions, Doc. 22.1.1—Plasterboard and Metal Pan—Suspended Ceilings Levels 2, 4 and 5	16/5/78	P.W.D., West Perth
21205 ....	Rural and Industries Bank, 101–103 St. George's Terrace—Lifts	23/5/78	P.W.D., West Perth
21206 ....	Carine Technical College Stage 1A—Automotive Spray Paint Booths	23/5/78	P.W.D., West Perth
21067 ....	Jerramungup Nursing Post—Repairs and Renovations (Recall)	23/5/78	P.W.D., West Perth P.W.D., A.D., Albany
21197 ....	The Queen Elizabeth II Medical Centre—Central Plant Building—Mech. 60.2.2 Chilled Water Plants 5 and 6—Pipework and Pumps	30/5/78	P.W.D., West Perth
21207 ....	Mandurah—Day Care Centre, Public Health Department—Erection	23/5/78	P.W.D., West Perth
21208 ....	Semi-Annual Planting Contract 1978–79—Western Australian Government Buildings	16/5/78	P.W.D., West Perth
21209 ....	Semi-Annual Grassing Contract 1978–79—Western Australian Government Buildings	16/5/78	P.W.D. West Perth
21210 ....	Yellowdine—Sale by Public Tender of Ptn Lot 12 on Plan 22328. The highest or any Tender not necessarily accepted.	16/5/78	P.W.D., West Perth
21211 ....	Fremantle Hospital—South Terrace Additions—Registration of Tenderers for Supply and Delivery of Lighting Equipment, Document 35.12	9/5/78	P.W.D., West Perth
21212 ....	Fremantle Hospital—South Terrace Additions—Registration of Tenderers for Rising Mains and Cable Trays, Doc. 35.3	9/5/78	P.W.D., West Perth

\* Deposit on Documents \$170.00

†Tenders close at the State Tender Board 74 Murray Street, Perth at 10.00 a.m.

‡Deposit for Documents \$100.

π Deposit for Documents \$100 per set.

§ Deposit for Documents \$150.

¶ Deposit on Documents \$50.

\*\* Deposit on Documents \$200.

†† Deposit on Documents \$90.

‡‡ Deposit on Documents \$60.

## ACCEPTANCE OF TENDERS

Contract No.	Project	Contractor	Amount
			\$
21076 ....	Balga Technical College—Major Additions 1978—Electrical Installation	Westwide Electrical Services	28 800
21089 ....	Kununurra District High School—8 Classrooms and Resource Centre Additions	Magee Constructions	542 000
21052 ....	Fremantle Hospital, South Terrace Additions—Refrigerated Chilled Water Plant, Mech. 36.10.1	Luke Air Conditioning	221 989

T. J. LEWIS,  
Under Secretary for Works.



P.V.O. 616/77

*Metropolitan Region Town Planning Scheme Act, 1959-1976; Public Works Act, 1902-1974*

## LAND RESUMPTION

*Parks and Recreation—Woodvale*

NOTICE is hereby given, and it is hereby declared, that the several pieces or parcels of land described in the Schedule hereto, being all in the Perthshire district have, in pursuance of the written approval and consent of His Excellency the Governor, acting by and with the advice of the Executive Council, dated the 12th day of April 1978, been set apart, taken or resumed for the purposes of the following public work, namely:—Parks and Recreation—Woodvale.

And further notice is hereby given that the said pieces or parcels of land so set apart, taken or, resumed are marked off and more particularly described on Plan, P.W.D., W.A. 50831, which may be inspected at the Office of the Minister for Works, Perth.

And it is hereby directed that the said lands shall vest in the Metropolitan Region Planning Authority for an estate in fee simple in possession for the public work herein expressed, freed and discharged from all trusts, mortgages, charges, obligations, estates, interests, rights-of-way or other easements whatsoever.

## SCHEDULE

No. on Plan P.W.D., W.A. No. 50831	Owner or Reputed Owner	Description	Area
1	Ante Radich	Portion of Perthshire Location 103 being Lot 53 on Plan 8364 and being all the land in Certificate of Title, Volume 19, Folio 364A, less portion resumed	2.02 ha

Certified correct this 17th day of March, 1978.

E. C. RUSHTON,  
Minister for Urban Development  
and Town Planning.

WALLACE KYLE,  
Governor in Executive Council.

Dated this 12th day of April, 1978.

P.V.O. 771/73

*Public Works Act, 1902-1974*

## NOTICE OF INTENTION TO RESUME LAND

*Extensions to the Alma Street School, Fremantle*

THE Minister for Works hereby gives notice in accordance with the provisions of section 17 (2) of the Public Works Act, 1902-1974, that it is intended to take or resume under section 17 (1) of that Act, the pieces or parcels of land described in the Schedule hereto, and being all in the Fremantle District, for the purpose of the following public work, namely:—Extensions to the Alma Street School, Fremantle, and that the said pieces or parcels of land are marked off on Plan P.W.D., W.A. 50908, which may be inspected at the office of the Minister for Works, Perth. The additional information contained in the Schedule after the land descriptions is to define locality only and in no way derogates from the Transfer of Land Act description.

## SCHEDULE

No. on Plan P.W.D., W.A. No. 50908	Owner or Reputed Owner	Occupier or Reputed Occupier	Description	Area (approx.)
1	Antonio Mentasana	Vacant	Portion of Fremantle Town Lot 712 and being Lot 3 on Diagram 7119 and being all of the land in Certificate of Title, Volume 1263, Folio 833	202 m <sup>2</sup>

Dated this 12th day of April, 1978.

R. J. O'CONNOR,  
Minister for Works.

*Main Roads Act, 1930-1977; Public Works Act, 1902-1972*

M.R.D. 1044/69-20

NOTICE OF INTENTION TO TAKE OR RESUME LAND

THE Minister for Works, hereby gives notice, in accordance with the provisions of section 17 (2) of the Public Works Act, 1902-1972, that it is intended to take or resume under section 17 (1) of that Act, the pieces or parcels of land described in the Schedule hereto, and being all in the East Fremantle District, for the purpose of the following public work, namely, road construction, and that the said pieces or parcels of land are marked off on Plan M.R.D., W.A., 7825-15, which may be inspected at the Office of the Commissioner of Main Roads, Waterloo Crescent, East Perth.

SCHEDULE

No.	Owner or Reputed Owner	Occupier or Reputed Occupier	Description	Area (approx.)
1	John Frederick Suriano and Shirley Mason Suriano	J F. and S. M. Suriano	Portion of Swan Location 63 and being part of Lot 4 on Plan 29 (Certificate of Title Volume 1297, Folio 519)	208 m <sup>2</sup>

Dated this 26th day of April, 1978.

W. J. ALLAN,  
Secretary.

METROPOLITAN WATER SUPPLY SEWERAGE AND DRAINAGE BOARD.

Metropolitan Water Supply.

Notice of Intention.

M.W.B. 825833/78.

NOTICE is hereby given, pursuant to section 20 of the Metropolitan Water Supply Sewerage and Drainage Act, 1909-1977, of intention of the Board to undertake the construction of the following works, namely:—

Town of Gosnells.

305 mm Feeder Main in Yale Road, Canning Vale North.

Description and Locality of Proposed Works:

The construction of a three hundred and five millimetre diameter water main, approximately one thousand one hundred and eighty metres in length complete with valves and all necessary apparatus.

Commencing at the intersection of Yale Road and Spencer Road, and proceeding thence in a South-Westerly direction along Yale Road to the junction of Yale Road and McMahan Street and terminating thereat.

The above works and localities are shown on plan M.W.B. 15255.

The Purpose for which the Proposed Works are to be Constructed:

The proposed constructed works are to augment the supply of water to the Canning Vale Area.

The Times when and Place at which the Plan may be Inspected:

At the office of the Board, Dumas House, corner of Kings Park Road and Havelock Street, West Perth, for one month on and after the 28th day of April, 1978, between the hours of 9 a.m. and 3.30 p.m.

F. ARMSTRONG,  
General Manager.

Note.

Sections 19, 21 and 22 of the Metropolitan Water Supply Sewerage and Drainage Act, 1909-1977, provide that any local authority or person interested may lodge a written objection with the Board against the construction or provision of the proposed works, within one month after the date of publication of the above notice.

After the period for receipt of objections has expired, and the objections, if any, have been met by amendment of the proposal or are, in the general public interest, not sufficient to cause the proposals to be amended, the Governor may make an order, a notice of which is published in the *Government Gazette*, authorising the Board to carry out the construction or provision of the proposed works.

METROPOLITAN WATER SUPPLY SEWERAGE AND DRAINAGE BOARD.

Notice of Intention.

M.W.B. 825837/77.

NOTICE is hereby given, pursuant to section 20 of the Metropolitan Water Supply, Sewerage and Drainage Act, 1909-1977, of intention of the Board to undertake the construction of the following works, namely:—

City of Fremantle.

305 mm Feeder Main in South Terrace, Fremantle.

Description and Locality of Proposed Works:

The construction of a three hundred and five millimetre diameter water main, approximately three hundred and ten metres in length complete with valves and all necessary apparatus.

Commencing at the junction of South Terrace, Essex Street and Henderson Street, and proceeding thence in a south easterly direction along South Terrace to a point in South Terrace approximately five metres north west of the junction of South Terrace and Arundel Street and terminating thereat.

The above works and localities are shown on M.W.B. Plan No. 15115.

The Purpose for which the proposed works are to be constructed:

The proposed constructed works are to augment the supply of water to the Fremantle Hospital.

The times and place at which the plan may be inspected:

At the office of the Board, Dumas House, corner of Kings Park Road and Havelock Street, West Perth, for one month on and after the 28th day of April, 1978, between the hours of 9.30 a.m. and 3.30 p.m.

F. ARMSTRONG,  
General Manager.

Note.

Sections 19, 21 and 22 of the Metropolitan Water Supply Sewerage and Drainage Act, 1909-1977, provide that any local authority or person interested may lodge a written objection with the Board against the construction or provision of the proposed works, within one month after the date of publication of the above notice.

After the period for receipt of objections has expired, and the objections, if any, have been met by amendment of the proposal or are, in the general public interest, not sufficient to cause the proposals to be amended, the Governor may make an order, a notice of which is published in the *Government Gazette*, authorising the Board to carry out the construction or provision of the proposed works.

**METROPOLITAN WATER SUPPLY SEWERAGE  
AND DRAINAGE BOARD.**

Metropolitan Water Supply.

Notice of Intention.

M.W.B. 819081/78.

NOTICE is hereby given, pursuant to section 20 of the Metropolitan Water Supply, Sewerage and Drainage Act 1909-1977 of intention of the Board to undertake the construction and provision of the following works, namely:—

City of Melville.

450 mm Water Main—Bateman—Murdoch Drive,  
South Street to Marsengo Road.

**Description and Locality of Proposed Works:**

The construction of a four hundred and fifty millimetre nominal diameter steel water main, approximately six hundred and ten metres in length commencing at the junction of Murdoch Drive and South Street and thence proceeding in a general northerly direction along Murdoch Drive to the junction of Marsengo Road and terminating thereat. The above main is to be below ground, complete with valve pits, scour pits and all necessary apparatus.

The above works and localities are shown on plan M.W.B. 15252.

The purpose for which the proposed works are to be constructed and provided.

To provide a water supply to the Bateman area. The times and place at which the plan may be inspected:

At the office of the Board, Dumas House, corner of Kings Park Road and Havelock Street, West Perth, for one month on and after the 28th day of April, 1978, between the hours of 9.30 a.m. and 3.30 p.m.

F. ARMSTRONG,  
General Manager.

**Note.**

Sections 19, 21 and 22 of the Metropolitan Water Supply Sewerage and Drainage Act, 1909-1977, provide that any local authority or person interested may lodge a written objection with the Board against the construction or provision of the proposed works, within one month after the date of publication of the above notice.

After the period for receipt of objections has expired, and the objections, if any, have been met by amendment of the proposal or are, in the general public interest, not sufficient to cause the proposals to be amended, the Governor may make an order, a notice of which is published in the *Government Gazette*, authorising the Board to carry out the construction or provision of the proposed works.

**METROPOLITAN WATER SUPPLY SEWERAGE  
AND DRAINAGE BOARD.**

Metropolitan Sewerage.

Notice of Intention.

M.W.B. 569651/78.

NOTICE is hereby given, pursuant to section 20 of the Metropolitan Water Supply, Sewerage and Drainage Act, 1909-1977, of intention of the Board to undertake the construction of the following works, namely:

City of South Perth—Bickley Street.

South Perth Pumping Station No. 6—Bickley Street, Relocation 1978. Connecting 100 mm Rising Main. Connecting 150 mm Gravity Sewers.

**Description and Locality of Proposed Works:**

- (a) Pumping Station located in proposed cul-de-sac at the Western end of Bickley Street near the north eastern boundary of the proposed freeway.

- (b) Section of 100 mm Rising Main connecting the Pumping Station in (a) to the existing Rising Main on the southern side of Bickley Street, a distance of about 15 metres.

- (c) Section of 150 mm gravity sewer commencing at the proposed manhole No. X1935 in Melville Parade opposite the proposed Bickley Street cul-de-sac and proceeding south easterly to the proposed manhole No. X1934 in the said Bickley Street cul-de-sac and across lots 36, 37 and 38 Melville Parade, along the boundary of the proposed freeway to terminate at the proposed manhole No. X1936 near the northern boundary of lot 38, Melville Parade, a distance of about 60 metres.

- (d) Section of 150 mm gravity sewer commencing at the proposed manholes No. X1934 in (c) proceeding easterly, and terminating at the proposed Pumping Station in (a), a distance of about 10 metres.

The above works and localities are shown on plan M.W.B. 15159.

The Purpose for which the Proposed Works are to be Constructed:

To replace existing Pumping Station located on vacant crown land opposite lot 36, Melville Parade, gazetted in *Government Gazette* on 27th November, 1964, and to replace sewerage pipes to be abandoned on proposed future freeway land.

The Times and Place at which the Plan may be inspected:

At the office of the Board, Dumas House, corner of Kings Park Road and Havelock Street, West Perth, for one month on and after the 28th day of April, 1978, between the hours of 9.30 a.m. and 3.30 p.m.

F. ARMSTRONG,  
General Manager.

**Note.**

Sections 19, 21 and 22 of the Metropolitan Water Supply Sewerage and Drainage Act, 1909-1977, provide that any local authority or person interested may lodge a written objection with the Board against the construction or provision of the proposed works, within one month after the date of publication of the above notice.

After the period for receipt of objections has expired, and the objections, if any, have been met by amendment of the proposal or are, in the general public interest, not sufficient to cause the proposals to be amended, the Governor may make an order, a notice of which is published in the *Government Gazette*, authorising the Board to carry out the construction or provision of the proposed works.

**METROPOLITAN WATER SUPPLY, SEWERAGE  
AND DRAINAGE BOARD.**

Metropolitan Main Drainage.

Notice of Intention.

M.W.B. File 489993/76.

NOTICE is hereby given, pursuant to section 20 of the Metropolitan Water Supply, Sewerage and Drainage Act, 1909-1977, of intention of the Board to undertake the provision and construction of the following works, namely:—

City of Stirling and Shire of Swan.

Widgee Road Branch Drain—Sections 6, 7 and 8.  
**Description and Locality of Proposed Works:**

- (a) Provision comprises the takeover by constitution as a Metropolitan Main Drain, that portion of the Widgee Road Branch Drain located within the Shire of Swan Town Planning Scheme No. 7, in the district of Malaga, and generally between Alexander Drive and McGilvray Avenue, Widgee Road and the Northern Perimeter Controlled Access Highway Reserve, as shown on plan M.W.B. 15219. The drain was constructed by contractors under in-

structions from consulting engineers and to the overall satisfaction of the Metropolitan Water Board.

The drain generally consists of:—

approximately 1 870 metres of reinforced concrete piped gravity drain of varying diameter from 375 mm to 750 mm, approximately 92 metres of twin 375 mm diameter mild steel pressure main, two open earth compensating basins and a pump station; all complete with necessary brick and concrete structures, manholes and other apparatus connected therewith.

- (b) The construction of approximately 1 380 metres of temporary shallow open earth drain to function as an outlet for that section of the Widgee Road Branch Drain described above.

The drain is to be located in the district of Malaga; in the eastern extremity of the Shire of Swan Town Planning Scheme No. 7; Controlled Access Road Reserve; Malaga Road, and in the Metropolitan Regional Planning Authority land, lots 10, 11 and 1 to 5 Widgee Road. Majority of drain length being sited parallel to Widgee Road and approximately 60 metres North of Widgee Road, as shown on plan M.W.B. 15219.

The Purpose for which the Proposed Works are to be Provided and Constructed:

For the disposal of surplus water within the catchment area served by the Widgee Road Branch Drain sections 6, 7 and 8.

The Times and Place at which the Plan May be Inspected:

At the office of the Board, Dumas House, corner of Kings Park Road and Havelock Street, West Perth, for one month on and after the 28th day of April, 1978, between the hours of 9.30 a.m. and 3.30 p.m.

F. ARMSTRONG,  
General Manager.

#### Note.

Sections 19, 21 and 22 of the Metropolitan Water Supply Sewerage and Drainage Act, 1909-1977 provide that any local authority or person interested may lodge a written objection with the Board against the construction or provision of the proposed works, within one month after the date of publication of the above notice.

After the period for receipt of objections has expired, and the objections, if any, have been met by amendment of the proposal or are, in the general public interest, not sufficient to cause the proposals to be amended, the Governor may make an order, a notice of which is published in the *Government Gazette*, authorising the Board to carry out the construction or provision of the proposed works.

#### SHIRE OF BOULDER.

##### STATEMENT OF RECEIPTS AND PAYMENTS FOR YEAR ENDED 30th JUNE, 1977.

Receipts.		\$
Rates	554 702.12	
Payments in Lieu of Rates	250.00	
Licenses	3 914.75	
Government Grants and Recoups	462 121.67	
Statutory Road Grants	206 314.00	
Income from Property	22 968.07	
Sanitation Charges	70 197.44	
Fines and Penalties	1 620.61	
Cemetery Receipts	1 219.65	
Other Fees	17 044.36	
Other Revenue	125 014.89	
Contribution to Works	601.25	
Private Works	41 392.59	
<b>Total Receipts</b>	<b>\$1 507 370.40</b>	

Payments.		\$
Administration—Staff	114 954.11	
Administration—Members	8 625.76	
Debt Services	231 069.02	
Public Works and Services—		
Sewerage Construction and Maintenance	12 567.48	
Road Construction and Maintenance	305 282.39	
Street Lighting	21 092.48	
Parks, Gardens and Recreation Grounds	110 924.21	
Buildings, Construction and Maintenance	86 011.60	
Caravan Park Improvements and Maintenance	14 052.43	
		549 930.59
Town Planning Control	10 186.10	
Library Operating Expenses	81 950.54	
Health Services	46 195.72	
Sanitation	73 449.21	
Bush Fire Control	7 007.58	
Traffic Control	2 107.91	
Building Control	14 733.61	
Cemetery Expenditure	2 163.76	
Public Works Overheads—Overallocated	Cr. 5 143.88	
Plant, Machinery and Tools—Purchases	70 622.87	
Plant Operation Costs—Underallocated	1 892.33	
Materials Purchased—Overallocated	Cr. 348.11	
Donations and Grants	40 699.87	
Other Works and Services	18 777.13	
Private Works	39 628.89	
Water Conservation	39 131.59	
Transfer to Plant Replacement Reserve	7 897.44	
Transfer to Long Service Leave Reserves	18 081.00	
All Other Expenditure	8 954.29	
Aboriginal and Unemployment Relief Grants	6 563.43	
<b>Total Payments</b>	<b>\$1 389 130.76</b>	

#### SUMMARY.

	\$
Debit Balance 1/7/76	122 539.78
Payments 1976-77 as per Statement	1 389 130.76
	1 511 670.54
Receipts 1976-77 as per Statement	1 507 370.40
Debit Balance 30th June, 1977	\$4 300.14

#### BALANCE SHEET AS AT 30th JUNE, 1977.

Assets.		\$
Current Assets—		
Sundry Debtors	198 131.20	
Stock	7 956.23	
Non-current Assets—		
Trust Fund Bank Balance	27 738.70	
Loan Funds Bank Balance	4 460.01	
Metal Crushing Plant Reserve Fund	4 358.95	
Plant Reserve Fund	7 897.44	
Housing Reserve Fund	17 729.09	
Long Service Leave Reserve Funds	14 918.47	
Sinking Fund	1 920.00	
Deferred Assets	118 716.15	
Fixed Assets (at cost less depreciation)	3 090 701.79	
Metal Crushing Plant Investment	48 473.05	
<b>Total Assets</b>	<b>\$3 543 001.08</b>	

#### Liabilities.

	\$
Current Liabilities	78 193.00
Non-current Liabilities—	
Trust Fund	27 738.70
Reserve Funds	44 903.95
Deferred Liabilities—Loan Liability	1 960 385.76
	\$2 111 221.41
<b>Total Liabilities</b>	<b>\$ 2 111 221.41</b>
Municipal Accumulation Account (Surplus) ... \$1 431 779.67	
<b>Total Assets</b>	<b>\$ 3 543 001.08</b>
<b>Total Liabilities</b>	<b>\$ 2 111 221.41</b>

Contingent Liability (approximately) \$2 936 387.01 of which \$1 150.21 is payable by Treasury Department; \$424.36 by Town of Kalgoorlie, and \$9 923.56 by Kalgoorlie Lake View Pty. Ltd.

METAL TRADING CONCERN.

REVENUE ACCOUNT FOR YEAR ENDED 30th JUNE, 1977.

	\$
Metal Sales .....	60 892.49
Stock on Hand 30/6/77 .....	15 735.12
Transferred from Net Revenue Account .....	48 301.55
	\$124 929.16
	\$
Stock on Hand 1/7/76 .....	31 445.75
Administration .....	12 310.78
Operation Costs .....	55 511.71
Raw Material .....	8 242.56
Quarrying Costs .....	75.00
Amortisation—Upgrading Report .....	672.36
Depreciation .....	16 671.00
	\$124 929.16

We certify that the figures and particulars contained in the Annual Statements are correct.

D. C. DAWS,  
President.  
R. G. HADLOW,  
Shire Clerk.

I certify having examined the books and accounts of the Shire of Boulder, also compared the statements of receipts and payments, adjustment accounts, and balance sheet, also supporting statements, numbered forms 6 to 8A (both inclusive) and found same to be correct in accordance with the books, accounts and documents produced.

W. Z. SENDZIMIR,  
Government Inspector of Municipalities.

SHIRE OF CARNAMAH.

Municipal Fund.

STATEMENT OF RECEIPTS AND PAYMENTS FOR THE YEAR ENDED, 30th JUNE, 1977.

Receipts.		\$
Rates .....		162 351
Licenses .....		695
Government Grants M.R.D. ....		110 292
Eneabba Town Streets .....		31 028
Local Authority Assistance .....		4 450
C.A.R. Fund .....		31 975
Income from Property .....		22 408
Sanitation .....		8 769
Cemetery .....		850
Plant and Sundry Sales .....		9 200
Fines and Penalties .....		25
Vermin Services .....		1
Unemployment Relief Grant .....		26 500
Grants Commission .....		41 500
All Other Revenue .....		216 320
		\$666 364

Payments.		\$
Administration:		
Staff Section .....		61 567
Members Section .....		3 218
Debt Service .....		90 061
Public Works and Service:		
Road Construction .....		93 557
Road Maintenance .....		54 077
Eneabba Town Streets .....		25 533
Street Lighting .....		2 706
Parks and Recreation Reserves .....		23 534
Buildings Construction .....		13 299
Buildings Maintenance .....		20 733
Furniture and Equipment .....		6 166
Water Supplies .....		3 869
Health Scheme .....		5 568
Sanitation .....		9 589
Bushfire Control .....		2 470
Cemetery .....		2 377
Operation Costs .....		1 241
Plant, Tools, etc. ....		12 692
Material Stocks (Cr.) .....		1 376
Donations and Grants .....		648
Other Works and Services .....		649
Unemployment Relief Grant .....		20 835
All Other Payments .....		122 638
		\$575 651

SUMMARY.

	\$
Debit Balance as at 1/7/1976 .....	30 088
Payments .....	575 651
	605 739
Receipts .....	666 364
	\$60 625
Credit Balance as at 30/6/1977 .....	\$60 625

BALANCE SHEET AS AT JUNE 30, 1977.

Assets.		\$
Current Assets:		
Cr. Balance at Bank .....		60 625
Refunds .....		32
Sundry Debtors .....		10 164
Stock .....		2 468
Non-Current Assets:		
Trust Fund Bank .....		979
Loan Capital Bank .....		8 293
Reserve Fund Bank .....		2 726
Deposits .....		5
Drums .....		661
Refunds—Trust .....		6
Deferred Assets .....		33 071
Fixed Assets .....		455 469
		\$574 499

Liabilities.

Current Liabilities:		\$
Sundry Creditors .....		15 914
Pre-Payments .....		2 127
Non-Current Liabilities:		
Library Deposits—Trust .....		18
Deposits—Trust .....		3
License Suspense:		
Trust .....		2
Reserve Fund L.S.L. ....		2 726
Trust Suspense .....		223
Unclaimed moneys (Trust) .....		108
C.R.C. 13+ Club .....		625
Deferred Liabilities:		
Loan Liability .....		326 136
Special Overdraft A/C .....		532
		\$348 414

SUMMARY.

	\$
Total Assets .....	574 499
Total Liabilities .....	348 414
Municipal Accumulation (Surplus) .....	\$226 085

TRADING FUND—DRIVE-IN THEATRE.

STATEMENTS OF RECEIPTS AND PAYMENTS FOR THE YEAR ENDED JUNE 30, 1977.

Receipts.		\$
Gate Takings .....		7 527
Advertising .....		60
Cash Advance .....		40
Dr. Balance 30/6/77 .....		16 023
		\$23 650
Payments.		\$
Dr. Balance 1/7/76 .....		6 312
Wages .....		6 088
Cash Advance .....		40
Film Hire .....		6 888
Maintenance .....		3 822
Ftg., Staty., etc. ....		500
		\$23 650

BALANCE SHEET.

TRADING FUND—DRIVE-IN THEATRE.

Assets.		\$
Fixed Assets:		
Plant and Equipment .....		3 346
Buildings .....		4 980
		\$8 236
Liabilities.		\$
Current Liabilities:		
Dr. Balance at Bank .....		16 023
Sundry Creditors .....		952
Deferred Liabilities:		
Interest on Loan .....		1 443
Capital Advance .....		10 000
		28 418
Less Net Loss .....		20 182
		\$8 236

We hereby certify that the figures and particulars contained in the Annual Statements are correct.

F. C. G. LUCAS,  
President.  
R. S. DUTCH,  
Shire Clerk.

## SHIRE OF TOODYAY.

STATEMENT OF RECEIPTS AND PAYMENTS  
FOR THE YEAR ENDED 30th JUNE, 1977.

Receipts.		\$
Rates .. .. .	79 525.62	
Licenses .. .. .	53 128.32	
Government Grants .. .. .	112 395.48	
Statutory Grants .. .. .	46 657.00	
Income from Property .. .. .	25 471.59	
Health and Sanitation .. .. .	12 245.34	
Water Supply .. .. .	—	
Fines and Penalties .. .. .	388.60	
Cemetery Receipts .. .. .	767.20	
Vermin .. .. .	32.40	
All Other Revenue .. .. .	111 851.77	
	<u>\$442 463.32</u>	

Payments.		\$
Administration:		
Staff Section .. .. .	30 381.96	
Members Section .. .. .	2 303.70	
Debt Service .. .. .	37 484.05	
Works and Service .. .. .	155 688.14	
Parks, Gardens and Recreation Grounds .. .. .	10 871.93	
Buildings Construction and Maintenance .. .. .	95 191.84	
Health and Sanitation .. .. .	18 937.30	
Vermin .. .. .	—	
Traffic .. .. .	1 481.15	
Bushfire Control .. .. .	1 132.62	
Cemetery .. .. .	1 992.34	
Purchase of Plant .. .. .	18 321.92	
Public Works Overheads Over Allocated .. .. .	—	
Plant Operation Costs Over Allocated .. .. .	Dr. 914.14	
Materials Purchased Not Allocated .. .. .	Dr. 148.51	
Statutory Grants Payments .. .. .	46 105.42	
Donations and Grants .. .. .	1 522.83	
Other Works and Services .. .. .	12 218.55	
All Other Expenditure .. .. .	4 141.00	
	<u>\$436 712.10</u>	

## SUMMARY.

Credit Balance 1/7/75 .. .. .	26 977.90
Receipts as per Statement .. .. .	442 463.32
	<u>449 441.22</u>
Payments as per Statement .. .. .	436 712.10
Credit Balance 30/6/77 .. .. .	<u>\$12 729.12</u>

## BALANCE SHEET AS AT 30th JUNE, 1977.

Assets.		\$
Current Assets .. .. .	27 194.13	
Non-current Assets .. .. .	43 882.29	
Deferred Assets .. .. .	5 549.47	
Fixed Assets .. .. .	500 609.03	
	<u>\$577 234.92</u>	
Liabilities.		\$
Current Liabilities .. .. .	23 800.14	
Non-current Liabilities .. .. .	26 637.50	
Deferred Liabilities .. .. .	3 997.02	
Loan Liabilities .. .. .	261 529.29	
	<u>\$315 963.95</u>	
Total Assets .. .. .	577 234.92	
Total Liabilities .. .. .	315 963.95	
Municipal Accumulation Account Surplus .. .. .	<u>\$261 270.97</u>	

We hereby certify that the figures and particulars above are correct.

I. V. MURRAY,  
President.  
B. F. HARRIS,  
Shire Clerk.

I have examined the books and accounts for the Shire of Toodyay for the year ended 30th June, 1977, and certify that the annual statement mentioned above corresponds with the books of account, vouchers and documents submitted for audit and in my opinion are correct subject to my report.

K. ROBERTSON,  
Inspector of Municipalities.

## SHIRE OF WILUNA.

STATEMENT OF RECEIPTS AND PAYMENTS  
FOR YEAR ENDED 30th JUNE, 1977.

Receipts.		\$
Rates .. .. .	32 514.85	
Licenses .. .. .	16.50	
Government Grants .. .. .	182 476.57	
CRTF Grant .. .. .	4 732.00	
Income from Property .. .. .	7 791.25	
Sanitation Charges .. .. .	1 617.00	
Cemetery Receipts .. .. .	165.00	
Vermin Receipts .. .. .	3 026.99	
Sale of Plant .. .. .	52 000.00	
Contribution to Debt Service .. .. .	4 648.63	
Other Revenue .. .. .	9 988.70	
Refunds .. .. .	9 973.24	
	<u>\$308 950.73</u>	

Payments.		\$	\$
Administration—			
Staff Section .. .. .	28 792.05		
Less Allocation to Works and Services .. .. .	9 149.10		
			19 642.95
Members Section .. .. .			802.96
Debt Service .. .. .			25 229.23
Public Works and Services .. .. .			66 901.52
Special Works Project D.A.A. .. .. .			5 475.05
Buildings—			
Construction and Equipment .. .. .			50.00
Maintenance .. .. .			4 586.62
Health Services .. .. .			49.00
Sanitations .. .. .			2 508.74
Dog Control .. .. .			11.45
Vermin Services .. .. .			12 483.40
Bush Fire Control .. .. .			10 196.41
Cemeteries .. .. .			760.01
Public Works Overheads .. .. .	6 989.47		
Less Allocated to Works .. .. .	6 989.47		
			75 765.96
Plant, Machinery and Tools .. .. .			32 238.25
Plant Operating Costs .. .. .			32 238.25
Less Allocated to Works .. .. .			—
Materials Purchases .. .. .			368.69
Transfer to Loan Fund .. .. .			3.00
Other Works and Services .. .. .			11 155.20
Refunds .. .. .			10 275.75
			<u>\$246 263.94</u>

## SUMMARY.

Credit Balance 1/7/76 .. .. .	40 992.59
Receipts .. .. .	308 950.73
	<u>349 943.32</u>
Payments .. .. .	246 263.94
Credit Balance 30/6/77 .. .. .	<u>\$103 679.38</u>

## BALANCE SHEET AS AT 30th JUNE, 1977.

Assets.		\$
Current Assets .. .. .	128 150.23	
Non-current Assets .. .. .	156.48	
Fixed Assets .. .. .	246 830.57	
	<u>\$375 137.28</u>	
Liabilities.		\$
Current Liabilities .. .. .	5 966.84	
Non-current Liabilities .. .. .	68.28	
Deferred Liabilities .. .. .	114 207.16	
	<u>\$120 242.28</u>	
SUMMARY.		\$
Total Assets .. .. .	375 137.28	
Total Liabilities .. .. .	120 242.28	
Municipal Accumulation .. .. .	<u>\$254 895.00</u>	

## TRADING FUND—ELECTRICITY UNDERTAKING.

STATEMENT OF RECEIPTS AND PAYMENTS  
FOR YEAR ENDED 30th JUNE, 1977.

Receipts.		\$
Balance 1/7/76 .. .. .	12 510.25	
Receipts .. .. .	6 912.66	
	<u>\$19 422.91</u>	
Payments.		\$
Payments .. .. .	4 552.82	
Balance 30/6/77 .. .. .	14 870.09	
	<u>\$19 422.91</u>	

## BALANCE SHEET AS AT 30th JUNE, 1977.

Assets.		\$
Current Assets	.....	14 885.80
Deferred Assets	.....	36 253.46
		\$51 139.26
Liabilities.		\$
Fixed Liabilities	.....	50 139.27
Capital Reserve Account	.....	999.99
		\$51 139.26

G. M. LUKIN,  
President.  
W. J. LAPHAM,  
Shire Clerk.

I have examined the books of accounts for the Shire of Wiluna for the year ended 30th June, 1977, and certify that the annual statements mentioned above correspond with the books of accounts, vouchers and documents submitted for audit and in my opinion are correct subject to my report.

M. J. BREMAN,  
Government Inspector of Municipalities.

## SHIRE OF BELMONT.

It is hereby notified for public information that Keith William Pleitner has been appointed as Assistant Poundkeeper/Security and By-laws

Officer for the Shire of Belmont from 17th April, 1978, for the purpose of assisting in the control of dogs and the supervision of Council's By-laws and as such has been appointed;

- (a) Authorised Officer under the Dog Act, the Local Government Act, 1960-77.
- (b) Authorised person under section 665B of the Local Government Act, 1960-77.
- (c) Poundkeeper under section 450 of the Local Government Act, 1960-77.
- (d) Authorised Officer for the purpose of control of any of the By-laws of the Council.

G. SWINTON BRAY,  
Shire Clerk.

## SHIRE OF PERENJORI.

It is notified for general information that Terrance Francis Meek is appointed Building Surveyor for the Shire of Perenjori as from the 20th March, 1978.

M. G. CRAIG,  
Shire Clerk.

## LOCAL GOVERNMENT ACT, 1960-1977

Shire of York

## SALE OF LAND FOR RATES

(Section 584)

NOTICE is hereby given that default in the payment of rates for a period of not less than three years having occurred, the Shire of York acting under the powers conferred by subdivision C of Division 6 of Part XXV of the Local Government Act, 1960-1977, will offer for sale by Public Auction, at the York Town Hall, Avon Terrace, York on Friday the 26th day of May, 1978 at 2.30 p.m., the pieces of land described in the schedule hereto.

L. O. DELAHAUNTY,  
Shire Clerk.

## SCHEDULE

Description of Land and Lot or Location Number	Title Reference	Area	Street/Road	Description of any Improvements	Name of Registered Proprietor	Name of Other Persons appearing to have an interest	Rates		Other Charges Due on the land
							Out-standing		
							\$	\$	
Avon Location V Lot 21	Vol. 20 Fol. 388	986 m <sup>2</sup>	Maxwell ....	Nil	Alfred Frederick Durlacher	Nil ....	92.98		Nil
York Suburban Lot S 262 Lot 163	Vol. 269 Fol. 120	1 037 m <sup>2</sup>	Cowan ....	Nil	Rebecca Endersby	Public Works Department	80.07		89.00 (water)
York Suburban Lot S 119	Vol. 166 Fol. 122	4 047 m <sup>2</sup>	Newcastle	Nil	John Riley ....	Public Works Department	79.91		137.00 (water)
York Town Lot 306 ....	Vol. 9 Fol. 11	3 971 m <sup>2</sup>	Brunswick	Nil	William Ouston	Public Works Department	104.85		79.30 (water)
Part Avon Location t	Mem. Book 9/199	2 023 m <sup>2</sup>	Bland ....	Nil	Eva Chipper ....	Nil	183.36		Nil
Part Avon Location V	Vol. 848 Fol. 11	665 m <sup>2</sup>	Bland ....	Nil	Emma Amelia Giles	Public Works Department	50.00		93.00 (water)
Part Avon Location t	Mem. Book 17/322	3 794 m <sup>2</sup>	Bason ....	Nil	Gladys May Mincham	Public Works Department Shire of York	42.00		44.20 (water) 45.26 (demolition)

## LOCAL GOVERNMENT ACT, 1960-1976

Municipality of the Shire of Mukinbudin

## SALE OF LAND FOR RATES

NOTICE is hereby given that default in payment for rates for a period of not less than three (3) years having accrued, the Shire of Mukinbudin, acting under the powers conferred by subdivision C of Division 6 of Part XXV of the Local Government Act, 1960-1976, will offer for sale by Public Auction, at the Office of the Council, Shadbolt Street, Mukinbudin, on Friday, 18th August, 1978, at 3.00 p.m., the piece of land specified in the Schedule hereto.

A. K. EARL,  
Shire Clerk.

## SCHEDULE

Names of Registered Owners and also of all other persons having an Estate or Interest in the Land	Amount of Rates owing	Description of land	Vol.	Folio
William Albert Carrod	\$1 053.84	Avon Loc. 25462	239	106A

## SHIRE OF SERPENTINE JARRAHDALÉ.

Honorary Litter Inspectors.

IT is hereby notified for public information that the following appointments of Honorary Litter Inspectors are made under section 665A of the Local Government Act, 1960-1977, as from 17th April, 1978, for the Shire of Serpentine Jarrahdale:—

Mr. A. M. Lewis.  
Mr. A. Gordin.  
Mr. P. Kargotich.  
Mr. R. Baker.

By Order of the Council,

R. J. BAKER,  
Shire Clerk.

## SHIRE OF WEST PILBARA.

Onslow.

IT is hereby notified for general information that Mr. S. W. Rees has been appointed Acting Shire Clerk to the West Pilbara Shire Council from 2nd to 19th May, 1978.

H. W. CLARK,  
Shire President.

## LOCAL GOVERNMENT ACT, 1960-1977.

City of Perth.

Temporary Closures of Streets.

NOTICE is hereby given that in accordance with the provisions of section 334 of the Local Government Act, 1960-1977, the Council proposes to seek the approval of His Excellency the Governor to temporarily close the streets shown below which are no longer in public use:—

- Portions of Beltana and Glenelg Streets, as shown on Main Roads Department Drawing No. 7725-97.
- Portion of Vincent Street, just west of Hann Street, as shown on Main Roads Department Drawing No. 7725-96.

The request for closure has been made by the Main Roads Department and the temporary closure will be effective until the Department is given Control of Access over the sections of road concerned.

Any person who desires to object to either of the proposals may deliver written grounds of his objection to the Council within thirty-five days of the date of publication of this notice.

By Order of the Council,

G. O. EDWARDS,  
Town Clerk.

## DOG ACT, 1976.

Shire of Gnowangerup.

Dog Catcher.

I hereby certify that Richard Graeme Wall has been appointed as dog catcher for the Shire of Gnowangerup with full powers under the auspices of the Dog Act, 1976, from Saturday, 29th April, 1978, until further notice.

R. J. SIMS,  
Shire Clerk.

## LOCAL GOVERNMENT ACT, 1960-1977.

Town of Kalgoorlie.

Notice of Intention to Borrow.

Proposed Loan (No. 105) of \$40 000

PURSUANT to section 610 of the Local Government Act, 1960-1977, the Council of the Municipality of the Town of Kalgoorlie hereby gives notice that it proposes to borrow moneys by the sale of a debenture on the following terms and for the following purpose: \$40 000 for a period of fifteen (15) years repayable at the office of the State Government Insurance Office, Perth, in thirty equal half-yearly repayments of principal and interest. Purpose: Erection of spectator stand at Sir Richard Moore Sport Centre.

Plans, specifications and estimates of cost, as required by section 609 of the Act, are available for inspection at the office of the Council during normal office hours for a period of thirty-five (35) days from the publication of this notice.

Dated this 18th day of April, 1978.

M. R. FINLAYSON,  
Mayor.

D. R. MORRISON,  
Town Clerk.

## LOCAL GOVERNMENT ACT, 1960-1977.

Shire of Cuballing.

Notice of Intention to Borrow.

Proposed Loan (No. 39) of \$3 000.

PURSUANT to section 610 of the Local Government Act, 1960-1977, the Cuballing Shire Council hereby gives notice that it proposes to borrow money by sale of debentures on the following terms and for the following purpose: \$3 000 for a period of 10 years repayable at the office of the Council by 20 equal half-yearly instalments of principal and interest. Purpose: Resealing of Netball Courts.



Plans, specifications and estimates of costs as required by section 609 of the Act are open for inspection at the office of the Council for 35 days after publication of this notice.

Repayments of principal and interest will be met by the Cuballing Netball Club and therefore will not be a charge against the ratepayers.

L. G. GROUT,  
President.  
T. W. BRADSHAW,  
Shire Clerk.

LOCAL GOVERNMENT ACT, 1960-1977.

Shire of Nannup.

Notice of Intention to Borrow.

Proposed Loan (No. 24) of \$27 000.

PURSUANT to sections 609 and 610 of the Local Government Act, 1960-1977, the Council of the municipality of the Shire of Nannup hereby gives notice that it proposes to borrow money by the sale of a debenture or debentures on the following term and for the following purpose: \$27 000 for a period of seven years at the current rate of interest, repayable at the office of the Council, Adam Street, Nannup, by fourteen half-yearly instalments of principal and interest. Purpose: To purchase one only Caterpillar 910 wheeled loader. Lending body Commercial Bank of Australia Ltd.

Estimates and statements as required by section 609 are open for inspection by ratepayers at the office of the Council during office hours for a period of 35 days after publication of this notice.

Dated this 20th day of April, 1978.

J. M. McKITTRICK,  
President.  
D. F. BOULTER,  
Shire Clerk.

LOCAL GOVERNMENT ACT, 1960-1977.

Shire of Pingelly.

Notice of Intention to Borrow.

Proposed Loan (No. 75) of \$6 000.

PURSUANT to section 610 of the Local Government Act, 1960-1977, the Council of the Shire of Pingelly hereby gives notice of its intention to borrow money, by the sale of debentures, on the following terms and for the following purpose: \$6 000 for a period of fifteen (15) years at ruling interest rates, repayable at the office of the Council, Pingelly, in thirty (30) equal half-yearly instalments of principal and interest. Purpose: Installation of air conditioning with associated works, in the Council office building.

Specifications and estimates of costs and a statement required by section 609 of the Act are open for inspection at the Office of the Council, during normal business hours, for a period of thirty-five (35) days after publication of this notice.

Dated this 26th day of April, 1978.

A. J. EVA,  
President.  
K. J. TILBROOK,  
Shire Clerk.

LOCAL GOVERNMENT ACT, 1960-1977.

City of Stirling.

Loans.

Department of Local Government,  
Perth, 26th April, 1978.

LG. ST-3-8.

IT is hereby notified for public information that His Excellency the Governor has approved of the construction of bowling greens and clubhouse

facilities for the Maylands Bowling and Recreation Club Inc. and the construction of tennis courts and clubhouse facilities for the Maylands Tennis Club on portions of Reserve 9323 being declared as works and undertakings for which money may be borrowed under the provisions of Part XXVI of the Local Government Act, 1960-1977, by the Stirling City Council.

R. C. PAUST,  
Secretary for Local Government.

LOCAL GOVERNMENT ACT, 1960-1977.

City of Stirling.

Lease of Land.

Department of Local Government,  
Perth, 26th April, 1978.

LG ST-4-4A.

IT is hereby notified for public information that His Excellency the Governor has directed, under the provisions of section 267 of the Local Government Act, 1960-1977, that the Stirling City Council may lease portion of Reserve 9323 to the Maylands Bowling and Recreation Club Inc. for a period of 21 years without calling public tenders.

R. C. PAUST,  
Secretary for Local Government.

LOCAL GOVERNMENT ACT, 1960-1977.

City of Stirling.

Closure of Private Street.

Department of Local Government,  
Perth, 8th June, 1977.

LG. ST-4-8B.

NOTICE is hereby given in pursuance of the provisions of section 297A of the Local Government Act, 1960-1977, that His Excellency the Governor has approved of the resolution passed by the Stirling City Council that the private street described as being portion of Swan Location 1257 and being part of the land coloured brown and marked R.O.W. on Plan 3697 and being part of the land comprised in Certificate of Title Volume 654, Folio 26, be closed and the land contained therein be allocated to adjoining Lots 103 and 104 Grace Street and 139 and 140 Hinderwell Street, as shown in the Schedule hereunder.

R. C. PAUST,  
Secretary for Local Government.

Schedule.

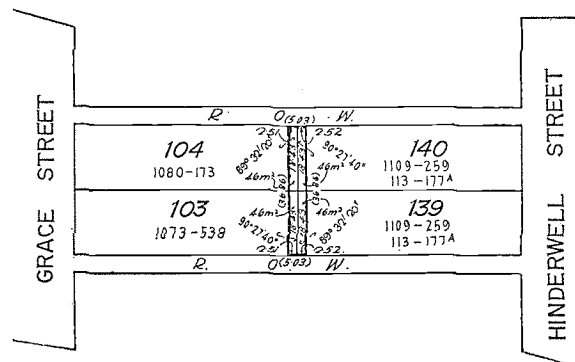

CLOTHES and FABRICS (LABELLING AND SALES)  
ACT, 1973-1977.

Department of Labour and Industry,  
Perth, 12th April, 1978.

HIS Excellency the Governor in Executive Council acting under the provisions of the Clothes and Fabrics (Labelling and Sales) Act, 1973-1977 has been pleased to make the regulations set forth in the schedule below.

H. A. JONES,  
Under Secretary for Labour and Industry.

Schedule.

REGULATIONS.

1. In these regulations the Clothes and Fabrics (Labelling and Sales) Act (Children's night clothes) Regulations, 1974 published in the *Government Gazette* on the 24th May, 1974 and amended by a notice so published on the 27th January, 1978 are referred to as the principal regulations.

2. Regulation 6 of the principal regulations is amended by revoking sub-regulation (2).

FACTORIES AND SHOPS ACT, 1963-1976.

Department of Labour and Industry,  
26th April, 1978.

Late Night Shopping.

IT is hereby notified with approval of the Minister for Labour and Industry, Mr. W. Grayden, and pursuant to section 84 of the Factories and Shops Act, 1963-1976, that any shop subject to the provisions of sections 85, 89, 90 and 91 of that Act is authorised, subject to any Award, addition to the hours specified in those sections to open during the hours of six o'clock in the afternoon and nine o'clock in the afternoon on the Thursday in each week of the week commencing on May 1, 1978, unless that day is a public holiday or public half holiday.

Provided that the above authority may be varied, to meet the need of the locality, to an alternative week night in any country town for which application is received by the Retail Trade Advisory and Control Committee.

H. A. JONES,  
Chairman,  
Retail Trade Advisory  
and Control Committee.

exercise of the power in this behalf conferred upon me by Regulation 5A of the Compulsory Fruit Fly Baiting Regulations, do hereby appoint Maxwell Clifford Armstrong, Padbury Road, Bridgetown, as a member of the Bridgetown Fruit Fly Baiting Scheme Committee to fill the vacancy caused by the resignation of C. H. Moore.

(Sgd.) R. C. OLD,  
Minister for Agriculture.

MURDOCH UNIVERSITY ACT, 1973-1976.

Office of the Minister for Education,  
28th April, 1978.

HIS Excellency the Governor, acting with the advice and consent of Executive Council and pursuant to sections 12 (1) and 14 of the Murdoch University Act, has been pleased to appoint Marilyn Anne Anthony of 14 Duncraig Road, Duncraig, to be the member selected from persons who are not members of either House of Parliament, nominated by the Leader of the Opposition for the remainder of the three year term of Marion Jefferson which expires on the 24th July, 1979.

P. V. JONES,  
Minister for Education.

PLANT DISEASES ACT, 1914-1974.

Department of Agriculture,  
South Perth, 21st April, 1978.

Agric. File 71/67.

I, the undersigned Minister for Agriculture, being the Minister charged with the administration of the Plant Diseases Act, 1914-1974, acting in the

STATE TENDER BOARD OF WESTERN AUSTRALIA

*Tenders for Government Supplies*

Date of Advertising	Schedule No.	Supplies Required	Date of Closing
1978			1978
April 7	209A/1978	Filter Floor Nozzles and Underdrainage System for Jandakot Water Treatment Works—M.W.B.	May 4
April 7	210A/1978	Fluoride Chemical (1 year period)—M.W.B.	May 4
April 7	221A/1978	Submersible Borehole Type Water Supply Pump Sets for Mirrabooka Artesian Bore No. 1A—M.W.B.	May 4
April 14	227A/1978	Reinforced Concrete (Pressure) Pipes—100 mm to 290 mm Nominal Diam. (1 year period)—M.W.B.	May 4
April 14	228A/1978	Machine Tool Equipment (1 or 2 year period)	May 4
April 14	229A/1978	V.H.F. Radio Equipment—P.W.D.	May 4
April 14	232A/1978	100 mm to 200 mm Cast Iron Pipes (1 year period)—M.W.B.	May 4
April 14	233A/1978	Weedicides (Ord Irrigation Area) (1 year period)	May 4
April 14	234A/1978	Firewood to Government Institutions at Perth, Fremantle, Midland, Gosnells, and Serpentine Main Dam (1 year period)	May 4
April 14	237A/1978	Mobile 3.5 m <sup>3</sup> /min. Air Compressor (1 only)—Department of Mines	May 4
April 14	239A/1978	Coffins (1 year period)—Community Welfare Department	May 4

STATE TENDER BOARD OF WESTERN AUSTRALIA—*continued**Tenders for Government Supplies—continued*

Date of Advertising	Schedule No.	Supplies Required	Date of Closing
1978			1978
April 14	240A/1978	Sheeting—Cotton; 50% Polyester 50% Cotton; Pillow Cotton; Loomstate Sheeting 50% Polyester 50% Cotton; Huckaback 61 cm—Govt. Stores. Dept.	May 4
April 21	246A/1978	Four Wheel Tractors (1 off to 7 off)—M.R.D.	May 4
April 21	245A/1978	Submersible Sewage Pumping Sets (2 only) for Claremont Pumping Station No. 7, Hackett Road—Re-organisation 1978	May 11
April 21	247A/1978	Magnetic Flowmeters for Jandakot Water Treatment Plant—M.W.B.	May 11
April 28	264A/1978	Tyres and Tubes (1 or 2 year period)	May 11
April 21	251A/1978	Haemodialysis Concentrate (1 year period)—Royal Perth Hospital and Sir Charles Gairdner Hospital	May 18
April 28	257A/1978	Tobacco for Swanbourne Hospital (1 year period)	May 18
April 28	258A/1978	Plastic Petri Dishes 9.0 cm dia. Gamma Sterilised (approx. 1 400 000) (1 year period)—State Health Laboratory Services	May 18
April 28	259A/1978	Lime Putty to Mirrabooka and Wanneroo Treatment Plants (1 year period)—M.W.B.	May 18
April 28	260A/1978	20 mm Nominal Dia. Stop Cocks—Approx. 24 500 (from date of acceptance to 30/9/79)—M.W.B.	May 18
April 28	263A/1978	Medical X-Ray Films and Developers (1 year period)—R.P.H.	May 18
April 28	270A/1978	Chlorine Dosing Equipment for Jandakot Water Treatment Plant—M.W.B.	May 18
April 28	261A/1978	Variable Speed Filter Backwash Pumps (2 only) for Jandakot Water Treatment Works—M.W.B.	May 25
April 28	262A/1978	Car and Wagon Wheels (500 only) and Wagon Axles (50 only)—W.A.G.R.	May 25
April 28	268A/1978	Oil Immersed Power Transformers (1 000 kVA—2 only: 500 kVA—6 only)—P.W.D.	May 25
April 28	269A/1978	Clear Water Pumping Sets (3 only) for Jandakot Water Treatment Works—M.W.B.	May 25

*For Sale by Tender*

Date of Advertising	Schedule No.	For Sale	Date of Closing
1978			1978
April 14	231A/1978	1975 Holden Station Sedan (UQR 706) at Wyndham	May 4
April 21	241A/1978	1968 Falcon Utility (UQA 977): 1969 Falcon Utility (UQF 218) at Gngangara	May 4
April 21	244A/1978	1942 Chevrolet 4 x 4 Jib Crane (UQD 825) at Mundaring Weir	May 4
April 21	248A/1978	Chrysler 9.5 h.p. Outboard Motor at East Perth	May 4
April 21	249A/1978	Wacker Plate Compactors (MRD 501, MRD 514) at East Perth	May 4
April 21	252A/1978	Various Vehicles—Sedans (11 only): Auto Sedans (2 only): Utilities (6 only): Station Sedans (4 only): Panel Vans (5 only): Trucks (3 only): Van (1 only): Cab and Chassis (1 only): Bus (1 only): 4 Wheel Drive (1 only) at various metropolitan locations	May 4
April 21	253A/1978	Holman Trailair 60 Portable Air Compressor (MRD 520) at East Perth	May 4
April 21	255A/1978	Keogh Towed Road Broom (UQV 328) at East Perth	May 4
April 14	236A/1978	1974 Landrover Utility (XGH 499) (Gearbox U/S) at Port Hedland	May 11
April 21	242A/1978	Various Vehicles—4 Wheel Drive (1 only): Sedans (2 only): Tractor (1 only): Grader (1 only): 5 Ton Truck (1 only) at Manjimup	May 11
April 21	243A/1978	Honda 750 cc Motor Cycles (20 only) at East Fremantle	May 11
April 21	250A/1978	Howard Tractor (MWB No. STP 15): 32 Volt Lighting Plant—Trailer Mounted (UQU 473): Repco Wheel Alignment Equipment at Shenton Park	May 11
April 21	254A/1978	FJ45 Landcruiser (MRD 835) at Kununurra	May 11
April 28	256A/1978	Wisconsin Engines (3 only) at Carlisle	May 11
April 28	265A/1978	Battery Charger (MRD 523) at East Perth	May 11
April 28	266A/1978	1975 Holden Belmont Sedans (UQR 834: UQR 837) at Kalgoorlie	May 18
April 28	267A/1978	1975 Dodge Utility (UQR 602) and Holden HJ Station Sedan (UQS 157) at Wyndham	May 25

Tenders addressed to the Chairman, State Tender Board, 74 Murray Street, Perth, will be received for the abovementioned schedules until 10 a.m. on the dates of closing.

Tenders must be properly endorsed on envelopes otherwise they are liable to rejection.

Tender forms and full particulars may be obtained on application at the Tender Board Office, 74 Murray Street, Perth and at points of inspection.

No Tender necessarily accepted.

B. E. CORBOY,  
Chairman, Tender Board

## ACCEPTANCE OF TENDERS

Schedule No.	Contractor	Particulars	Department Concerned	Rate
73A/78	Various	Supply—Kitchen equipment as specified	P.W.D.	Details on application
89A/78	Various	Supply—Milk, pasteurised as specified	Various	Details on application
94A/78	Wabco Dist. Aust.	Supply—One (1) only crawler dozer as specified	M.R.D.	For the sum of \$41 262.00
102A/78	Various	Supply—Groceries as specified	Various	Details on application
122A/78	Wigmores Tractors	Supply—Tractor shovel as specified	M.R.D.	For the sum of \$40 872.00
50A/78	N. Y. Mansour	Purchase and removal Holden station sedan 1975 model (UQS 239) at South Hedland	P.W.D.	For the sum of \$1 650.00
132A/78	Various	Purchase and removal various lighting Plants at Derby	P.W.D.	Details on application
144A/78	P. S. Hendrey	Purchase and removal stock saddles two (2) only at Maylands	Police Dept.	Details on application
148A/78	F. G. & R. J. Farr	Purchase and removal Chamberlain tractor super 90 at East Perth	M.R.D.	For the sum of \$2 800.00
63A/78	R. K. Wilkin	Purchase and removal Ford utility (NSW HTS 944) at Pannawonica	Police Dept.	For the sum of \$20.00
173A/78	G. D. Halton	Purchase and removal Holden panel van (UQR 726) at Geraldton	P.W.D.	For the sum of \$1 400.00
174A/78	T. McIntyre	Purchase and removal Holden station sedan (UQS 621) at Port Hedland	P.W.D.	For the sum of \$2 111.00
181A/78	William Wood Motors	Purchase and removal Dodge utility (UQS 965) at Forrestfield	Agric.	For the sum of \$1 711.00

## CANCELLATION OF CONTRACT

181A/78	Jandakot Motors	Purchase and removal Dodge utility (UQS 965) at Forrestfield	Agric Dept.
---------	-----------------	--	-------------

GOVERNMENT PRINTING OFFICE OF W.A.  
TENDERS FOR GOVERNMENT PRINTING

Tenders are invited for the supply of the undermentioned stores.  
Tenders close at Wembley, at 10.00 a.m. on 8th May, 1978.

Tender No.	Particulars of Stores
XS 5026	15 000 Continuous Forms. Size 11 x 8 in.
XS 5028	200 Books of 50 in triplicate. Size 225 x 133 mm.
XS 5029	500 Vinyl Binder Covers. Size 353 x 465 mm. Flat size.
XS 5030	500 Books of 50 in triplicate. Size A5.
XS 5038	50 Pads of 100 leaves. Size A4.
XS 5039	20 000 Return Address envelopes. Size 8½ x 3½ in.
XS 5040	100 000 Return Address envelopes. Size 164 x 109 mm.
XS 5041	20 000 Return Address envelopes. Size 7½ x 4 in.
XT 2724	400 Pads in triplicate. Size 130 x 110 mm.
XS 5042	1 000 Pads in triplicate. Size A4.
XT 2725	1 000 Books of 26 leaves. Size 342 x 260 mm.
XT 2727	50 Books of 50 in triplicate. Size 114 x 164 mm.
XS 5043	1 000 Books of 50 in triplicate. Size 230 x 120 mm.
XT 2729	2 000 overlapping invoices. Size 4½ x 14 in.
XT 2728	10 000 1 Part Continuous cheques. Size 89 x 266.
XS 5045	200 000 Window faced envelopes. Size 165 x 92 mm.

## SPECIAL NOTE—STOCK:

Tenderers are requested to specify—

1. Country of origin.
2. Brand or make of material.
3. In this contract preference may be given to W.A. or other Australian made stocks in accordance with Government Policy.

## ACCEPTANCE OF TENDERS

Tender No.	Particulars of Stores	Successful Tenderer	Amount
XT 2690	300 Books of 50 in duplicate Form 55/50/2050	Swan Print	\$ 276
XS 2709	20 000 1 Part Continuous	Barclay & Sharland	479

WILLIAM C. BROWN,  
Government Printer.

## COMPANIES ACT, 1961-1975.

Amelco (W.A.) Pty. Limited  
(in Voluntary Liquidation).

Notice of General Meeting.

NOTICE is hereby given that a General Meeting of the members of the company in pursuance of section 272 of the Companies Act, will be held at Peat, Marwick Mitchell & Co., 31st Level, Australia Square, Sydney, at 9.30 a.m. on 29th May, 1978, for the purpose of:—

- (1) Having an account showing how the winding up has been conducted and the property of the company disposed of laid before them.
- (2) Hearing any explanation given by the Liquidator.
- (3) Determining by resolution the manner in which the books and papers of the company shall be disposed of.

Dated at Sydney this 5th day of April, 1978.

A. R. M. MacINTOSH,  
Liquidator.

That the Company be wound up voluntarily and that Bernard Putnin be appointed liquidator for the purpose of winding up in view of the inability of the Company by reason of its liabilities to continue its business.

- (2) In the event of the contributories in the general meeting having resolved that the company go into voluntary liquidation to nominate a liquidator or if the members have nominated a liquidator to consider the confirmation of his appointment.
- (3) If thought fit to appoint a Committee of Inspection pursuant to section 262 of the W.A. Companies Act, 1961-1975.
- (4) To fix the remuneration of the proposed liquidator or to delegate such power to the Committee of Inspection if appointed.
- (5) Any other business.

Dated this 20th day of April, 1978.

V. VITASOVIC,  
Director.

(Putnin Marsden & Byers, Public Accountants,  
11 Emerald Terrace, West Perth, W.A. 6000.)

## COMPANIES ACT, 1961-1975.

(Section 254.)

Voluntary Winding-up.

New Holdings Pty. Ltd.

TAKE notice that on the 14th April, 1978, the members of the above company passed the following resolution:—

That this company be voluntarily wound up and that William Albert Thornton, Chartered Accountant, of 66 Thomas Street, West Perth, be appointed liquidator.

R. R. H. DORAN,  
Chairman.

(Thornton Pallot & Associates, Chartered Accountants, P.O. Box 46, West Perth 6005.)

## COMPANIES ACT, 1961-1975.

(Section 254.)

Voluntary Winding-up.

R.K.R. Investments Pty. Ltd.

TAKE notice that on the 14th April, 1978, the members of the above company passed the following resolution:—

That this company be voluntarily wound up and that William Albert Thornton, Chartered Accountant, of 66 Thomas Street West Perth, be appointed liquidator.

R. R. H. DORAN,  
Chairman.

(Thornton Pallot & Associates, Chartered Accountants, P.O. Box 46, West Perth 6005.)

## COMPANIES ACT, 1961-1975.

Notice of Meeting of Creditors.

G. & V. Constructions Pty Ltd.

NOTICE is hereby given that a meeting of creditors of G. & V. Constructions Pty Limited will be held at the offices of Putnin Marsden & Byers, Public Accountants, 11 Emerald Terrace, West Perth, W.A., on Friday, the 19th day of May, 1978, at 11.00 o'clock in the forenoon.

Agenda:

- (1) To receive a report from a Director of the company nominated by general meeting of members to be held at 11 Emerald Terrace, West Perth, W.A., on Friday, May 19, 1978, at 10.30 a.m.

## COMPANIES ACT, 1961-1975.

Baker & Barnett Pty. Ltd. (in Liquidation).

(Section 272 (1).)

Notice of Final Meeting of Members and Creditors.

NOTICE is hereby given that pursuant to the provisions of section 272 (1) of the Companies Act, 1961-1975, a meeting of members of Baker & Barnett Pty. Ltd. (in Liquidation) and of the Creditors of that company will be held on Friday, 26th May, 1978, at 10.30 a.m. at the offices of Allan Bradshaw & Associates, 282-284 Newcastle Street, Perth, for the purpose of laying before the meeting an account showing how the winding up has been conducted and the property of the company has been disposed of and giving any explanation of the account.

Dated at Perth this 20th day of April, 1978.

ALLAN W. BRADSHAW,  
Liquidator.

(Allan Bradshaw & Associates, 282-284 Newcastle Street, Perth.)

## COMPANIES ACT, 1961-1975.

Notice of Intention to Declare a Third and Final Dividend.

Baker & Barnett Pty. Ltd. (in Liquidation).

NOTICE is hereby given to Creditors that I, Allan William Bradshaw, Liquidator of Baker & Barnett Pty. Ltd. (in Liquidation) intend to declare a Third and Final Dividend in this matter on Friday, 26th May, 1978.

Creditors must prove their claim on or before the 15th May, 1978. Creditors failing to prove their debts by that date shall be excluded from any distribution.

Dated at Perth this 20th day of April, 1978.

ALLAN W. BRADSHAW,  
Liquidator.

(Allan Bradshaw & Associates, 282-284 Newcastle Street, Perth.)

## COMPANIES ACT, 1961-1975.

Supreme Court (Companies) Rules, 1963.

Advertisement for Creditors to Prove their Claims.

Span Homes Pty Ltd (in Liquidation).

THE creditors of the abovenamed company are hereby advised that I have fixed Friday, the 12th of May, 1978, as the certain day on or before which day the creditors of the company are to prove their debts or claims and to establish any title they may have to priority under section 292 of the Companies Act, 1961-1975, or be excluded from the benefit of any distribution made before those debts are proved, or, as the case may be, from objecting to the distribution.

Creditors claims are to be submitted on a Proof of Debt form only, which should set out their names and addresses and the particulars of their debts or claims and the names and addresses of their solicitors, if any, and be forwarded to the liquidator of the above company, Dudley Norman Allan, Chartered Accountant, 10th Floor, T & G Building, 37 St. George's Terrace, Perth, by the above date.

Creditors who have already lodged a proof, need not lodge another.

Dated this 21st day of April, 1978.

D. N. ALLAN,  
Liquidator.

## COMPANIES ACT, 1961-1975.

(Section 260 (2).)

Notice of Meeting of Creditors.

Bill Watts (Engineers) Pty Ltd, 15 Drake Street, Osborne Park.

NOTICE is hereby given that pursuant to section 260 (2) of the Companies Act, 1961-1975, a meeting of creditors of Bill Watts (Engineers) Pty Ltd. will be held at Allendale Square, Suite 2, 31st Floor, 65 St. George's Terrace, Perth 6000, on Wednesday, 10th May, 1978, at 10.30 a.m. to consider a proposed special resolution:—

That the company be wound up voluntarily and that Messrs. Rodney Michael Evans and Maurice Hodgson Lyford be and are now appointed Joint & Several Liquidators of the Company.

Dated at Perth this 21st day of April, 1978.

W. WATTS,  
Director.

(Melsom Wilson & Partners, 11th Floor, T & G Building, 37 St. George's Terrace, Perth, W.A. 6000.)

## COMPANIES ACT, 1961-1975.

(Section 272.)

Notice of Final Meeting of Members.

Hill Holdings Pty. Ltd. (in Liquidation.)

NOTICE is hereby given that, pursuant to the provisions of section 272 of the Companies Act, 1961-1975 a meeting of the members of Hill Holdings Pty. Ltd. will be held on Monday the 12th day of June, 1978, at 11.00 a.m. at the offices of Hungerfords, 16th Floor, 37 St. George's Terrace, Perth, for the purposes of laying before the meeting an account showing how the winding up was conducted and the property of the company disposed of and of giving any explanations of the account.

Dated at Perth this 21st day of April, 1978.

R. S. NORGARD,  
R. W. BROWN,  
Joint Liquidators.

(Hungerfords Chartered Accountants, 16th Floor, 37 St. George's Terrace, Perth, W.A. 6000.)

## COMPANIES ACT, 1961-1975.

Supreme Court (Companies) Rules, 1963.

Advertisement for Creditors to Prove their Claims.

Lutine Marine and General Insurance Co. Pty. Ltd. (in Liquidation).

THE creditors of the abovenamed company are hereby advised that I have fixed the 12th day of May, 1978, as the certain day on or before which day the creditors of the company are to prove their debts or claims and to establish any title they may have to priority under section 292 of the Companies Act, 1961-1975, or be excluded from the benefit of any distribution made before those debts are proved, or, as the case may be, from objecting to the distribution.

Creditors claims are to be submitted on a Proof of Debt form only, which should set out their names and addresses and the particulars of their debts or claims and the names and addresses of their solicitors, if any, and be forwarded to the liquidator of the above company, Dudley Norman Allan, Chartered Accountant, 10th Floor, T & G Building, 37 St. George's Terrace, Perth, by the above date.

Creditors who have already lodged a proof, need not lodge another.

Dated this 24th day of April, 1978.

D. N. ALLAN,  
Liquidator.

## COMPANIES ACT, 1961-1975.

Notice of Resolution.

Ord Securities Pty. Ltd.

AT an extraordinary general meeting of the members of Ord Securities Pty. Ltd. duly convened and held at 33 Ord Street, West Perth, on the 18th day of April, 1978, the Special Resolution set out below was to be passed:—

1. That the company be placed in voluntary liquidation and for this reason the Liquidator be empowered to distribute the assets of the company in specie.
2. That Neville John Owen of 28 Outram street, West Perth, Solicitors, being eligible and having consented to act in writing be appointed Liquidator of the Company and that his remuneration be fixed at professional rates applicable plus out of pocket expenditure.

Dated this 24th day of April, 1978.

N. J. OWEN,  
Liquidator.

(Messrs. Bryant & Owen, Solicitors of 28 Outram Street, West Perth.)

## COMPANIES ACT, 1961-1975.

(Section 272.)

Nigel Satterley Pty. Ltd. (In Liquidation).

NOTICE is hereby given that the Final General Meeting of the Company and the Creditors will be held at the office of A. Millman, Chartered Accountant, 18 Emerald Terrace, West Perth on Tuesday 30th May, 1978, at 11.30 a.m.

Agenda:

1. To receive the Liquidator's Report on the conduct of the winding up.
2. To approve the Liquidator's fees and expenses.
3. To grant authority to the Liquidator to destroy the books and papers of the Company within three months after the date of dissolution of the Company.

Dated this 27th day of April, 1978.

A. MILLMAN,  
Liquidator.

## COMPANIES ACT, 1961-1975

(Section 272.)

Satterley Investments Pty. Ltd. (In Liquidation).

NOTICE is hereby given that the Final General Meeting of the Company and the Creditors will be held at the office of A. Millman, chartered Accountant, 18 Emerald Terrace, West Perth on Tuesday 30th May, 1978, at 11.00 a.m.

## Agenda:

1. To receive the Liquidator's Report on the conduct of the winding up.
2. To approve the Liquidator's fees and expenses.
3. To grant authority to the Liquidator to destroy the books and papers of the Company within three months after the date of dissolution of the Company.

Dated this 27th April, 1978.

A. MILLMAN,  
Liquidator.

IN THE SUPREME COURT OF  
WESTERN AUSTRALIA.

1978, Company No. 19.

In the matter of the Companies Act, 1961-1975 and in the matter of Delta Distributors Pty. Ltd. and in the matter of a Petition presented the 3rd day of April, 1978.

NOTICE is hereby given that a Petition for the winding up of the abovenamed Company by the Supreme Court was, on the 3rd day of April, 1978, presented by the Deputy Commissioner of Taxation for the State of Western Australia, and that the said Petition is directed to be heard before the Court sitting at the Supreme Court, Perth at the hour of 10.30 o'clock in the forenoon on the 22nd day of May, 1978; and any creditor or contributory of the said Company desiring to support or oppose the making of an order on the said Petition may appear at the time of hearing by himself or his counsel for that purpose; and a copy of the Petition will be furnished to any creditor or contributory of the said Company requiring the same by the undersigned on payment of the regulated charge for the same.

The Petitioner's address is The Australian Taxation Office, Commonwealth Government Centre, 1-3 St. George's Terrace, Perth in the said State.

The Petitioner's Solicitor is Alan R. Neaves, Commonwealth Crown Solicitor of 9th Floor, Lombard House, 251 Adelaide Terrace, Perth aforesaid.

ALAN R. NEAVES,  
Commonwealth Crown Solicitor and  
Solicitor for the Petitioner.

Note: Any person who intends to appear on the hearing of the said Petition must serve on or send by post to the abovenamed Petitioner's Solicitor notice in writing of his intention so to do. The notice must state the name and address of the person, or, if a firm, the name and address of the firm, and must be signed by the person or firm, or his or their Solicitor (if any) and must be served, or, if posted, must be sent by post in sufficient time to reach the abovenamed, not later than four o'clock in the afternoon of Friday the 19th day of May, 1978.

## TRUSTEES ACT, 1962.

## Notice to Creditors and Claimants.

CREDITORS and other persons having claims (to which section 63 of the Trustees Act, 1962, relates) in respect of the Estates of the undermentioned deceased persons are required by the Perpetual Executors, Trustees and Agency Company (W.A.) Limited of 89 St. George's Terrace, Perth, to send particulars of their claims to the Company by the

undermentioned date after which date the said Company may convey or distribute the assets having regard only to the claims of which the Company then has notice.

Claims for the following expire 2nd June, 1978.  
Hastings, John Richard, late of 229 Corinthian Road, Riverton, Water Borer and Reticulator. Died 17th January, 1978.

Skelton, Julia Lewin, late of Lake View Lodge, 5 Britannia Road, Mount Lawley, Spinster. Died 8th February, 1978.

Smethurst, Lillias, late of 5A Ripplewood Avenue, Thornlie, Widow. Died 4th March, 1978.

Socmas, Spiridon, otherwise known as Socmas Spiro, late of 71 Baden Street, Joondanna, Railway Wagon Examiner. Died 22nd February, 1978.

Strachan, Ruby Irene Rochfort, late of Como Nursing Home, Talbot Avenue, Como, formerly of Flat 9, 44 Mill Point Road, South Perth, Widow. Died 19th January, 1978.

Dated at Perth this 24th day of April, 1978.

The Perpetual Executors, Trustees and Agency Company (W.A.) Limited.

B. A. BUTCHER,  
General Manager.

## PUBLIC TRUSTEE ACT, 1941-1975.

NOTICE is hereby given that pursuant to section 14 of the Public Trustee Act, 1941-1975, the Public Trustee has elected to administer the estates of the undermentioned deceased persons.

P. W. MCGINNITY,  
Public Trustee,  
665 Hay Street, Perth.

Name of Deceased; Occupation; Address;  
Date of Death; Date Election filed.

Bayliss, Alice Matilda; Married Woman; Yokine; 9/11/77; 7/4/78.

Collas, William Henry; Retired Labourer; Perth; 24/12/77; 7/4/78.

Halbert, Thomas Graham; Retired Business Proprietor; Nedlands; 11/12/60; 7/4/78.

Godley, Frank; Invalid Pensioner; Claremont; 1/2/78; 7/4/78.

Watts, Alfred Hilton; Paper Seller; Perth; 12/1/78; 7/4/78.

Knox, Hubert James; Retired Debt Collector; Embleton; 22/1/78; 7/4/78.

Weeks, Frederick George; Retired Prospector; Norseman; 15/10/77; 7/4/78.

Buchanan, Ernest; Retired P.M.G. Department Employee; Nollamara; 24/2/78; 7/4/78.

Julian, Arthur; Retired Cabinet Maker; Perth; 7/1/78; 7/4/78.

Keay, Hector Charles; Retired Electrical Inspector; North Perth; 11/2/78; 7/4/78.

Leeds, Elsie Gertrude; Married Woman; Wilson; 15/2/78; 7/4/78.

Palmer, Elizabeth Harriet; Widow; Joondanna; 21/2/78; 7/4/78.

Rose, George Spencer; Retired Electrician; Karawara; 23/2/78; 7/4/78.

Trotter, Alexander; Truck Driver; Riverside Gardens; 7/10/77; 7/4/78.

Normington, Boulton; Retired Railway Employee; Bassendean; 12/10/77; 7/4/78.

Burns, Thomas Frazer; Retired Labourer; Bate-man; 23/11/77; 7/4/78.

## TRUSTEES ACT, 1962.

## Notice to Creditors and Claimants.

CREDITORS and other persons having claims (to which section 63 of the Trustees Act relates) in respect of the Estates of the undermentioned deceased persons are required to send particulars of their claims to me on or before the 29th day of May, 1978, after which date I may convey or distribute the assets, having regard only to the claims of which I then have notice.

Dated this 20th day of April, 1978.

P. W. MCGINNITY,  
Public Trustee,  
565 Hay Street, Perth.

Name; Address and Occupation; Date of Death.

Bennell, Carnera; 492 William Street, Perth, Labourer; 5/8/76.

Brewer, Cecilie Mabele; 91 Manning Street, Scarborough, Widow; 27/3/78.

Brockman, Henry Spicer Prinsep; 199 Stock Road, Palmyra, Retired Clerk; 9/3/78.

Brown, Margaret Antionette; 130 Petra Street, Bicton, Spinster; 19/2/78.

Conway, Edward; State Battery Darlot, W.A., Labourer; 28/1/78.

Corlett, William Arthur; formerly of 3 Wilga Street, Maddington; late of Warrabri Mission, Northern Territory, Cabinet Maker; 6/12/76.

Fulthorp, Alice; Riverview Residence, Pendleton Street, Collie, Widow; 9/2/78.

Geensen Schelte Anthonie; 1 Grenada Place, Safety Bay, Retired School Master; 16/9/77.

Gibson, Dianne; c/o Kailis Gulf Fisheries, Learmonth, Spinster; 13/10/77.

Gilmour, Gordon Granville; 134 Wharf Street, Cannington, Gas Meter Repairer; 3/4/78.

Grant, Keith McKenzie; Kenetic Marble Mine, Manutarra, via Onslow, Station Manager; 14/8/77.

Hay, Margaret Reynolds; 4 Grand Promenade, Bayswater, Spinster; 30/3/78.

Hughan, Leonard David; Quininup Mill, via Mandurah, Truck Driver; 4/4/78.

Kandler, Herbert Gunther; Caravan Park, Karatha; Boiler Maker; 8/11/77.

Lauritsen, Reginald Ellis; Mt. Mulgine, via Perenjori, Miner; 5/2/76.

Lidberia, Ida; Derby, Widow; 24/1/78.

Lindsay, John; 15 Braxan Street, Glen Forrest, Retired School Teacher; 18/3/78.

Linney, Stanley Albert; 176 Coode Street, Bedford, Retired Bus Driver; 3/3/78.

Marsh, Daniel Frederick; Single Mens Quarters, Mt. Newman Mining Co, Port Hedland, Maintenance Worker; 16/3/78.

Merritt, Leslie; Mount Goldsworthy, W.A., Carpenter; 30/11/77.

Russell, Ronald Walter; 27 Lantana Way, Kelm-scott, Stores Supervisor; 27/11/77.

Searle, Roland Maxwell; 1 Strickland Street, Mt. Claremont, Caretaker; 3/4/78.

Simpson, Clara Ellen; formerly of Leake Street, Belmont; late of Guildford Nursing Home, 63 Helena Street, Guildford, Spinster; 4/4/78;

Weston, George Samuel; Nazareth House, Hilton, Retired Motor Salesman; 6/8/77.

Williams, John Stamford; 12 Ormond Road, Mt. Barker, Retired Shire Employee; 13/1/78.

Wilson, John Henry; 238 Shepperton Road, East Victoria Park, Retired General Hand; 3/12/77.

## REPORT OF THE HONORARY ROYAL COMMISSION OF INQUIRY INTO THE TREATMENT OF ALCOHOL AND DRUG DEPENDENTS IN WESTERN AUSTRALIA, 1973.

(Hon. R. J. L. Williams, M. L. C., Chairman.)

## Prices—

Counter Sales—\$1.50

Mailed—\$1.90

### GOVERNMENT GAZETTE

## NOTICE TO SUBSCRIBERS

**COPY DEADLINE:** All copy for publication must be in the hands of the Government Printer by 3 p.m. on the WEDNESDAY before publication.

WILLIAM C. BROWN,  
Government Printer.

### SPECIAL NOTICE.

Concerning "Government Gazette" notices for publication lodged at the Government Printer's Wembley Office—notice must be lodged with "Parliamentary Papers" Salvado Road, Wembley prior to 3.00 p.m. on the Wednesday before publication.

WILLIAM C. BROWN J.P.  
Government Printer.

### CONTENTS.

	Page
Agriculture, Department of	1294
Bush Fires Act	1280
Chief Secretary's Department	1277
Clothes and Fabric Labelling Act	1294
Companies Act	1297-9
Crown Law Department	1277
Deceased Persons' Estates	1300
Dog Act	1292
Factories and Shops	1294
Finance Brokers Control Act	1271
Health Department	1278
Land Agents Act	1269-71
Lands Department	1278-80
Local Government Department	1291-4
Metropolitan Region Planning	1285
Metropolitan Water Supply, etc.	1286-8
Mines Department	1276-7
Municipalities	1288-91
Murdoch University Act	1294
Notices of Intention to Resume Land	1285-6
Plant Diseases Act	1294
Police Department	1278
Premier's Department	1269
Public Service Board	1272-7
Public Trustee	1299
Public Works Department	1282-6
Resumptions	1285
Supreme Court Act	1278
Tender Board	1294
Tenders Accepted	1296
Tenders for Government Printing	1296
Tenders Invited	1282-4
Town Planning	1280-2
Trustees Act	1299-1300