

Government Gazette

OF

WESTERN AUSTRALIA

(Published by Authority at 3.30 p.m.)

No. 24]

PERTH : FRIDAY, 3 APRIL

[1981

NOTICE TO SUBSCRIBERS.

“GOVERNMENT GAZETTE” EASTER HOLIDAYS.

IT is hereby notified for public information that the “Government Gazette” for Easter week will be published on **THURSDAY, 16 APRIL 1981**, in lieu of Good Friday.

All notices for publication must be in the hands of the Government Printer before 3 p.m. on **TUESDAY, 14 APRIL 1981**.

WILLIAM C. BROWN,
Government Printer.

(3) declare that the office of councillor for the South Ward which is abolished by effect of this Order shall be that office which on 23 May 1981 will become vacant by effluxion of time; and

(4) direct that an election be held on 23 May 1981 for the election of a person to the additional office of councillor created by this Order for the Coastal Ward.

J. E. A. PRITCHARD,
Acting Clerk of the Council.

AT a meeting of the Executive Council held in the Executive Council Chambers at Perth this 1st day of April, 1981, the following Order in Council was authorised to be issued.

Local Government Act 1960.
ORDER IN COUNCIL.

LG:DN-1-8.

WHEREAS in the Local Government Act 1960 (as amended) it is provided—

- (i) by section 10 that the Governor may, by Order, declare the number of offices of councillor of a municipality and for a ward of a municipality;
- (ii) by section 20 that the Governor may, by Order determine matters relating to the representation of electors on the council of a municipality:

Now therefore His Excellency the Governor acting with the advice and consent of the Executive Council pursuant to the provisions of sections 10 and 20 of the Local Government Act 1960, does hereby:—

- (1) declare that the number of offices of councillor of the municipality of the Shire of Dandaragan shall be 9;
- (2) declare that after 23 May 1981 the number of offices of councillor for the wards of the Shire of Dandaragan shall be as follows:—

Coastal Ward—3
South Ward—2
Central Ward—2
North Ward—2;

Western Australia.

FINANCE BROKERS CONTROL ACT 1975.

(Sections 24 and 27.)

Application for Finance Brokers Licence
by Individual.

To: The Registrar, Finance Brokers Supervisory Board: I, **PETER JOHN TAYLOR** of 8 Chesney Street, Morley 6062, hereby apply for a Finance Brokers Licence under the Finance Brokers Control Act 1975. My address for service of notices in respect of this application is 7th Floor, 105 St. George's Terrace, Perth.

Dated this 24th day of March, 1981.

(Signed) **P. J. TAYLOR.**

Appointment of Hearing.

I hereby appoint the 6th day of May, 1981, at 9.00 o'clock in the forenoon as the time for hearing the foregoing application at the Offices of the Finance Brokers Supervisory Board, 184 St. George's Terrace, Perth.

C. A. FITZGERALD,
Registrar,
Finance Brokers Supervisory Board.

Objection to the granting of this licence shall be in the approved form and may be served on the applicant and the Registrar at any time prior to seven days before the date appointed for the hearing.

Western Australia.
FINANCE BROKERS CONTROL ACT 1975.
(Sections 24 and 27.)

Application for Finance Brokers Licence
by Individual.

To: The Registrar, Finance Brokers Supervisory Board:
I, RANDOLPH WILLIAM WIERINGA of 77 The
Esplanade, Mount Pleasant, W.A. 6153, hereby apply
for a Finance Brokers Licence under the Finance
Brokers Control Act 1975. My address for service
of notices in respect of this application is 77 The Esplan-
ade, Mount Pleasant, W.A. 6153.

Dated this 10th day of March, 1981.

(Signed) RANDOLPH WILLIAM WIERINGA.

Appointment of Hearing.

I hereby appoint 6 May 1981 at 9.00 o'clock in the
forenoon as the time for hearing the foregoing appli-
cation at the Offices of the Finance Brokers Supervisory
Board, 184 St. George's Terrace, Perth.

C. A. FITZGERALD,
Registrar,
Finance Brokers Supervisory Board.

Objection to the granting of this licence shall be in
the approved form and may be served on the appli-
cant and the Registrar at any time prior to seven
days before the date appointed for the hearing.

Crown Law Department,
Perth, 3 April 1981.

IT is hereby notified for public information that His
Excellency the Governor in Executive Council has:—

Approved of the following appointments to the Com-
mission of the Peace for the State of Western
Australia:—

Donald Robert Fisher of "Glen Muick", Hines Hill.
Richard Henry Jenkins of 21 Fitzpatrick Way,
Padbury and S. W. Hart & Co. Pty. Ltd.
112 Pilbara Street, Welshpool.

R. M. CHRISTIE,
Under Secretary for Law.

Chief Secretary's Department,
Perth, 25 March 1981.

THE Hon. Chief Secretary has approved the appoint-
ment of the following persons as Commissioners for
Declarations under the Declarations and Attestations
Act 1913-1972:—

Bullingham, Gilbert Lloyd; Brentwood.
Clark, David John; Kardinya.
Cole, Ernest James; Melville.
Davey, Andrew Hilton; Duncraig.
Day, Elspeth Margaret; Balga.
Fincher, William Ronald; Scarborough.
Hall, John Desmond; Riverton.
Holman, Harvey Sydney; Duncraig.

Oxenburgh, Marian; Wembley.
Redden, Vincent Patrick; Karrinyup.
Ridge, Margaret Joan; Greenwood.
Taylor, Edward Graham; Katanning.
Wilson, Ian Francis; Geraldton.
Ayres, Frank Disney Adey; Redcliffe.
Bradshaw, Gillian; Duncraig.
Burman, Neil Timothy Charles; City Beach.
Clarson, David Charles; Armadale.
Gomes, Quentin Francis Xavier; Bullcreek.
Harris, Pasker Kent Wynn; Forrestfield.
Haynes, Raymond Arthur; Kondinin.
Lawrence, Bernard George; Kewdale.
Lemon, Ronald Arthur; Broome.
Nedkoff, Louie; Duncraig.
Newman, David John; East Victoria Park.
Phillips, Russell David; Noranda.
Price, Henry Thomas Stuart; Mount Claremont.
Sexton, John Daryl; Como.

K. G. SHIMMON,
Director.

HEALTH ACT 1911-1979.

Municipality of the Shire of Wickepin.

PURSUANT to the provisions of section 57 of the
Health Act 1911-1979 the Shire of Wickepin gives notice
it intends to construct a sewerage scheme in Wickepin
Townsite as permitted by section 54 of that Act and
that in accordance with section 55 of that Act the
application, general plan and description of the pro-
posed scheme have been forwarded to the Commissioner
of Health, for approval.

A copy of the general plan and description may be
inspected at the Office of the Shire of Wickepin during
normal business hours.

Objections to the proposed scheme will be received
within one month after the publication of this notice
in the *Government Gazette*, as provided by section 58.

W. I. WEIR,
Shire Clerk.

CORRIGENDUM.

HEALTH ACT 1911 (AS AMENDED).

City of Cockburn.

By-laws Relating to Stables.

THE following correction is made to the notice of
Amendments to Stable By-laws on page 392 of *Govern-
ment Gazette* No. 7 of 23 January 1981.

Signature Group—

Delete "A. R. ARMAREGO".

Insert "A. J. ARMAREGO".

J. C. McNULTY,
Commissioner of Public Health
and Medical Services.

HEALTH ACT 1911 (AS AMENDED).

Fremantle City Council.

PHD 589/65; Ex. Co. 0959.

WHEREAS under the provisions of the Health Act 1911 (as amended), a local
authority may amend, repeal or alter by-laws so made: Now, therefore, the City of
Fremantle being a local authority within the meaning of the Act and having made
by-laws relating to the removal of house and trade refuse as printed in the *Government
Gazette* of 16 June 1970, doth hereby make the following amendment:—

Part 9 subsection (D) is amended by deleting the words forty five dollars (\$45.00)
in the second line and replacing with fifty dollars (\$50.00).

Passed by the Council of the City of Fremantle at the ordinary meeting of the
Council held on the 15th day of December 1980.

W. A. McKENZIE,
Mayor.
S. W. PARKS,
Town Clerk.

Approved by His Excellency the Governor in Executive Council this 18th day of
March, 1981.

J. E. A. PRITCHARD,
Acting Clerk of the Council.

HOSPITALS ACT 1927-1980.

Department of Health
and Medical Services,
Perth 3 April 1981.

PL 1.9.

HIS Excellency the Governor in Executive Council has been pleased to appoint under the provisions of the Hospitals Act 1927-1980 Mr. G. Gutteridge as a member of the James T. Pollard Convalescent Hospital Board for the period ending 30 September 1981 *vice* Mr. J. A. Spence resigned.

W. D. ROBERTS,
Director,
Hospital and Allied Services.

POLICE ACT 1892-1902.

THE following unclaimed stolen and found property will be sold by Public Auction at the Property Tracing Section, Police Complex, Clarkson Road, Maylands, on Tuesday 14 April 1981 at 9.00 a.m.

Conditions of Sale.

1. The highest bidder shall be the purchaser.
2. The Vendor shall have the right to bid by the Auctioneer or the Vendor's Agent for any lot offered.
3. The Auctioneer may, without giving any reason therefore, refuse to accept the bid of any person or persons and may decline the offer for any lot or withdraw any lot or lots from the sale.
4. Should any dispute arise as to any bid, the relevant lot or lots may at the option of the Auctioneer be put up again and resold.
5. No allowance or refunds will be made nor will any buyer be permitted to reject any lot on the ground that it is not correctly described in the Catalogue; the said lots are to be taken with all faults (if any) and will be at the buyer's risk on the fall of the hammer.
6. All goods which have been paid for in full must be removed by the purchaser at the purchaser's expense by the close of the sale.
7. Time shall be the essence of the sale of any lot.
8. Whilst every care has been taken in the compilation of this Catalogue the Auctioneers and/or Vendors accept NO RESPONSIBILITY for any misdescription and make no warranty whatsoever.
Measurements and quantities shown are approximate and intended only as a guide to prospective purchasers.
9. Payment strictly on fall of hammer.

FOUND PROPERTY 2/81.

- 80/108—Y/m lady's Cynryn watch, jerry can and some petrol, umbrella, film, 5 x purses, 7 x y/m bracelets, w/m ring with whitestone, w/m pendant, y/m lady's Citizen watch and strap, Sanyo clock radio, 2 x pairs speakers, 1 x Pioneer car cassette radio, 1 x National radio, 1 x battery shaver, 3 keys, sunglasses, book, 1 x pair ear studs, umbrella, leather bag, child's purse, 4 x pairs pantyhose, 1 pair trousers, spectacle case, top, peeler masker, hat, jumper, 4 x w/m trophies, 2 x cricket ball trophies, 1 x reel wire, handbag, purse, sunglasses, keys, clothing, wheel chair, 2 x umbrellas, brooch, 3 x cardigans, light meter, sunglasses, w/m bracelet, y/m lady's Orling watch and band, cigarette lighter, 1 pair jeans, w/m gent's Seiko watch and band, 1 x No. 9 iron gold club, umbrella.
- 80/109—Purse and odd items, school bag and books.
- 80/110—Child/s plastic car set and game "Buggy Race".
- 80/111—4 x LP records.
- 80/112—Carrybag, jersey, hat, handkerchief.
- 80/114—Tool box and assorted tools.
- 80/115A—Handbag and contents.
- 80/116—1 pair sunglasses, 2 x wallets, torch, 2 pairs glasses, w/m bracelet, 4 x stubbies beer, Hanimette camera, handbag.

- 80/117—Y/m Orotan purse, foreign coin, 4 used stamps, pendant.
- 80/118—Sundry items ex. Myer.
- 80/119—Steel Craft stroller, Sanyo radio, book, key case.
- 80/120—Y/m bracelet, handbag, purse.
- 80/121—Sundry items ex. Myer.
- 80/122—Truck tyre and rim 1000 x 20.
- 80/123—Y/m earring, cheese cloth top.
- 80/124—W/m pendant fine silver 9998 x 10 g.
- 80/125—Gas bottle, radio aerial.
- 80/128—W/m lady's Felicia w/w, leather band.
- 80/129—Polaroid 100 camera, y/m ring with 4 white stones, 1 x pen.
- 80/130—1 x lawn mower grass catcher.
- 80/131—Duffel bag and clothing, toiletries, square harmonica, 2 cups, canister, book, 2 x umbrellas, handbag, glasses and contents, 1 pair sandals, handbag and cosmetics, purse, torch, pocket knife.
- 80/132—Wallet.
- 80/133—Sundry items ex. W.A. University.
- 80/134—1 x blanket.
- 80/135—1 x clothes bag and clothing.
- 80/136—1 x warning light.
- 80/137—Sundry items ex. Mt. Lawley Teachers College including 3 watches.
- 80/138—Sundry items ex. Mt. Lawley Teachers College.
- 80/139—1 x 12 in. child's push cycle with trainer wheels, wallet, purse, y/m pendant, w/m ladies Citizen w/w, 1 x stroller, case and clothing, 5 books, 3 tea towels.
- 80/140—Travel clock, alarm clock, AWA radio, small quantity groceries, 3 x knives, purse and mirror.
- 80/141—Vinyl bag and knife, handbag.
- 80/142—Books, purse, pencil case.
- 80/143—2 x y/m rings.
- 80/144—Case and clothing.
- 80/145—Tarpaulin.
- 80/146—Tyre lever.
- 80/147—Purse with strap, 4 x blankets, pillow, quilt, 2 x eiderdowns.
- 80/148—Knife, length pipe, tomahawk, 1 x crescent spanner, keys in pouch, 1 x sheepskin cover, 5 x bottles beer.
- 80/149—2 x purses, pair spectacles, wallet.
- 80/151—W/m ladies Citizen w/w, w/m pendant, w/m pocket watch, w/m ladies w/w.
- 80/152—1 x jacket.
- 80/153—2 x items tools.
- 80/155—Philips radio.
- 80/156—W/m pendant and chain.
- 80/157—W/m gents Guda w/w.
- 80/158—Y/m watch and band, bag and 2 beach towels, 2 pairs shorts, 2 shirts, 4 plastic toys, bracelet chain.
- 80/159—2 x purses, toilet bag, clothing, razor, linen, blanket, dustbin, groceries, blouse, w/m mesh purse, suitcase and clothing.
- 80/160—Vinyl shoulder bag, ring with stone missing.
- 80/161—2 pairs boots.
- 80/162—Purse.
- 80/163—W/m gents w/w Chevron, y/m ladies w/w Felicia, w/m ladies w/w Algex, w/m gents w/w Timex.
- 80/164—W/m gents w/w Seiko.
- 80/165—Purse, pocket knife, keys, 2 jumpers, foreign money, carry bag, tomahawk, knife, gloves, umbrella, suitcase, beanbag. Philips TV set B and W old condition.
- 80/169—W/m gents ring with black stone, approx 5 gallons diesel in container, y/m wristlet chain, w/m necklace, clothing, handbag, 2 lipsticks.
- 80/170—Sundry items ex. Myers.
- 80/171—Keys in key wallet.

- 80/172—Purse, key.
- 80/178—1 pair shoes, cricket bat, horse halter, and lead strap, handbag, cardigan.
- 80/179—1 x 10 ft. foam canoe.
- 80/180—Windrush surfcat bag and sail.
- 80/181—2 x w/m Orotan purses, key, purse.
- 80/182—1 x bottle Tora Tequila.
- 80/183—Riding whip, 1 x pair glasses.
- 80/184—Sundry items ex. WAIT including 4 rings, 1 watch, 2 calculators, Sanyo radio.
- 80/185—1 x torch, 1 x vehicle rear window louvre.
- 80/186—Sundry items ex. Parlourcars.
- 80/187—Y/m ring with 16 small stones and 1 white stone, w/m gent's w/w Seiko, w/m gent's w/w Timex, y/m brooch with 4 coloured stones.
- 80/188—Y/m and w/m wristlet chain, bag with 2 towels and clothing, carry bag and clothing, 2 x knives.
- 80/189—Rim and tyre complete, clothing, foam mattress and cover, handbag and Orotan purse.
- 80/190—Torch and batteries.
- 80/192—Purse and cosmetics, 1 x 195/70 hr 14 tyre, mirror, suit coat and sundry items.
- 80/193—1 x bag insulation, 3 x bottles beer, 2 x wallets, radio, tape measure, 6 x items tools, spark plugs.
- 80/194—1 x box firearm cleaning tools, case and cassettes.
- 80/195—Wallet.
- 80/197—W/m gent's w/w Seiko, purse, chain.
- 80/198—2 x purses.
- 80/199—W/m Timex w/w, jerry can and petrol, 1 pair shoes, clothing, keys, 4 pieces aluminium.
- 80/200—Beach umbrella.
- 80/201—Purse, y/m lady's w/w Citizen, w/m gent's w/w Bulova, w/m gent's w/w Surena, cycle lock.
- 80/202—Purse, bag, assorted ropes, iron, pegs, groceries, carpet, 2 burner primus gas stove, hose, tent, 20 tent supports, cigarette lighter, National radio, 1 x 308 Holden top overhaul gasket set.
- 80/203—9 x stubbies beer, wet suit, y/m lady's w/w Felicia, w/m gent's w/w Citizen, tyre lever.
- 80/204—1 x jumper.
- 80/205—1 x pair boltcutters.
- 80/206—1 x cardigan.
- 80/388—7 ft. dinghy—damaged oar and rowlock, damaged fishing net 2½ in. mesh.
- 80/396—7 ft. dinghy, bondwood.
- 81/47—8 ft. dinghy, bondwood—damaged and damaged fishing net.
- STOLEN PROPERTY 2/81.
- 79/1089—Sheepskin seat cover, w/m Uniktime w/w, y/m ring, w/m ring with blue stone, w/m necklace with blue stone, CB radio hand-piece, power meter and matcher, canvas bag and quantity tools, tool box and drill bits.
- 79/1097—2 x Tinkerbell cosmetic packs.
- 79/1098—Clothing, 2 bangles, hair conditioner, sunglasses.
- 80/25—Electric clock, colour flash camera and flash unit, damaged Sharp radio-cassette player.
- 80/28—Car battery.
- 80/30—1 x Mag rim and tyre, 1 x 25 piece socket set, 1 x lambswool seat cover, 1 x bedspread, 2 x blankets, 3 items kitchen utensils, 7 x drinking mugs, 1 x adjustable wrench, 1 x school bag, 1 x hair cream, 1 x razor.
- 80/31—1 x National clock radio, 1 x damaged Jarvis Walker fishing rod.
- 80/33—Clothing.
- 80/34—Motor cycle helmet.
- 80/38—3 x pot plants, 2 x earthenware pipes, 2 x leadlight glass, 1 x sign, 1 x cap, 1 x coil, 1 x Sanyo radio-cassette player, 1 x ear phone, 1 x fountain pen and refill, 1 x cigarette lighter, 1 x pocket knife, 1 x metal pocket calendar, 2 x pairs shoes, clothing, wallet, y/m chain and birthsign.
- 80/39—Jumper, 5 x items bedclothes, sunglasses, 12 cassette tapes, 1 x calculator, pocket knife, 1 x Philips radio, 1 x case and speaker, 1 radio speaker, pipe and tobacco, 2 x Polaroid cameras, clothing.
- 80/42—Sleeping bag and clothing, plastic bin and clothing, AWA turntable, 2 x AWA speakers, clock radio, handbag, 2 x damaged radios, 42 LP records, 22 x 45 RPM records, 14 cassette tapes, 1 x ear phone, book, 2 x clocks damaged, keys, bag, 2 x pairs boots, 1 x radio, 2 x cassette holders, 1 x CB aerial, 1 x Pioneer car cassette player and amplifier, 2 x Clarion speakers, 1 x bedspread.
- 80/45—Hawk tune-up kit, 4 brake shoes, auto testing kit, 6 fan blades, mirror, ignition switch, torch, starter motor, Holden distributor, manifold, car badges, horn, coil, motor cycle battery.
- 80/46—2 x Oxy hoses, 5 oxy gauges, 1 x hand piece.
- 80/47—1 x box building pegs.
- 80/48—1 x box used clothing.
- 80/49—1 x Menzel pump, car jack, 7 x spot lights and 4 covers, tow bar tongue, service manual V8 Valiant, Ford hub cap.
- 80/50—Picnic set, carry bag, torch, football flag.
- 80/51—2 x ruck sacks.
- 80/52—2 x car batteries.
- 80/53—2 x fire extinguishers.
- 80/54—1 x box assorted used linen and clothes.
- 80/55—2 x 70/14 radial tyres, 1 x 78/14 tyre and rim, 2 x 70/14 mag rims and tyres, 1 x 14 in. rim.
- 80/56—1 x Sansui amplifier, 1 x Pioneer 8 track car player, 1 x car radio and 8 track player, 1 x National radio, 1 x Rambler radio, 1 x Kodak Instamatic camera, 1 x Canon camera, 3 x calculators, 1 x Philips mini cassette player, 2 x car radios, 1 x Philips radio, 2 x LP records, 1 x record case.
- 80/57—1 x tow hitch, 1 x aerial, 1 hammer, 1 x hydraulic jack, 1 x hand saw, 1 x Speco-Thomas floor shift conversion, 1 x jemmy bar, glove, 1 x riding whip.
- 80/59—1 x Sansui speaker.
- 80/60—3 x tool boxes, with assorted tools.
- 80/61—5 x umbrellas.
- 80/62—Camera case, car speaker, 1 x Capro 400 movie camera, National walkie-talkie radio, K-mart radio, 1 x Polaroid camera, 1 x Sanyo portable radiogram, 1 x Lucas 8 track player.
- 80/63—1 x case sundry used clothes, 1 x overnight case.
- 80/64—Toolbox and tools, tow bar, 3 x car louvres 1 x mesh sunvisor, 2 x car aerials.
- 80/65—1 x y/m digital w/w, 1 x warning lamp, 1 x fishing reel, 1 x trouble light, 1 x rudder, 1 speaker.
- 80/67—1 x Orotan purse.
- 80/67A—4 x items tools.
- 80/68—1 x Webber carburettor, 1 x generator, 1 x carburettor, 1 x cassette tape holder, 10 x cassette tapes, 1 x tool box and tools, 1 x radar snooper.
- 80/69—1 x 6 string Yamaha guitar and shoulder strap.
- 80/71—2 x fishing rods, 2 x fishing reels Dam, various items fishing gear.
- 80/73—1 x Philips radio.
- 80/75—1 x Tromba loud hailer.
- 80/77—1 x y/m with red and white stones, gents ring.
- 80/80—2 x sets cuff links, 1 x y/m expanding watch band.
- 80/84—1 x wooden and laminated container.
- 80/85—6 x car louvres, 1 x warning light.
- 80/86—2 x small pieces carpet, 1 x pair shoes.

- 80/89—1 x car louvre, 1 x adding machine.
 80/92—3 x knives, 1 x meat cleaver.
 80/94—1 x Casio calculator, 1 x hair brush, 2 x pens, 1 x letter opener, 1 x Kodak instamatic camera, 1 x Muir boat winch, quantity sundry items, 1 x pair earrings, 2 x y/m ear studs, 2 x w/m rings, quantity copper wire, school bag and assorted tools, tool box and assorted tools, Lightburn electric drill, hand drill and bits.
 80/95—Part first aid kit in box, clothing.
 80/100—Quantity used clothing, sleeping bag, JVC radio and cassette player, 1 pair shoes, wheel brace, bag, 2 pairs sunglasses, 3 brushes, set y/m bells, w/m gents w/w Gada.
 80/101—1 x 8 in. wheel and tyre, 6 x records, 1 x barometer, Australian flag, 9 x curtains, 1 x lampshade, 1 x National radio, 1 x jerry can and hose, quantity clothing, y/m cross and chain.
 80/104—Container and 21 cassette tapes, 2 x car speakers, 1 x knife, 1 pair glasses, w/w gents.
 80/106—1 x set jumper leads, 1 x Holden jack.
 80/107—Wallet.
 80/108—1 x Emu 7 x 50 Binoculars, 1 x y/m gents w/w Timex.
 80/111—Y/m wrist chain, fishing tackle box, 4 x cassette tapes, 1 x Pioneer car cassette player, 2 x Pioneer car speakers.
 80/112—1 x Sunbeam toasted sandwich maker, 1 x radio, 2 x set headphones, 1 x Sunbeam hair dryer, 1 x Copal electric clock, 1 x National radio, 1 x w/m bracelet.
 80/114—Toy, auto kit, 1 x Casio mini calculator, 1 x cassette tape, y/m gents w/w, keys, pocket knife, 1 x case, 1 x Kodak camera, w/m Casio gents w/w.
 80/115—1 x aluminium window frame, 12 lengths 4 in. x 2 in. timber.
 80/116—Wallet.
 80/117—1 x set of four Gabriel air adjustable shock absorbers.
 80/118—Oxy set, hoses and cutter, 2 x headlights, 4 x Holden hubcaps, 1 x car louvre.
 80/119—2 x metal car ramps.
 80/123—Purse, keys, 1 x 18 channel Sharp CB radio.
 80/124—1 x vehicle louvre, 36 cigarettes, 2 packets tobacco.
 80/125—2 x bumper jacks, 1 x part bumper jack.
 80/126—Bolt cutters, 2 x 2 way hand held radios, 2 torches, 5 items tools, jumper-leads, breath test machine, gloves.
 80/127—1 x GE electrical clock, 1 x spot light.
 80/128—21 items tools, sunglasses, torch, gloves, 3 x knives.
 80/130—National V T R Videscope machine.
 80/134—2 x pairs pliers, 1 x car aerial, gear lever knob, 1 brace and bit.
 80/136—Kodak camera, 2 x items tools, pipe, 1 x pair binoculars, air cleaner, pair jeans, 2 rolls film, cycle pump, 1 x Philips radio and cord, 6 cans spray paint, 3 pieces aluminium 90 x 60 cm, 1 car battery.
 80/137—10 x packets cigarettes.
 80/143—Tool box and assorted mechanic tools, 27 piece socket set.
 80/145—1 x packet playing cards, 1 x roll tape, 1 x Sharp calculator, 1 x pillow, 1 x knife, 1 x spanner, 1 x torch.
 80/146—Twin S U carburettors.
 80/148—6 x blankets, seat cover, crockery, chair, frying pan, Kodak camera, 2 x plastic chairs.
 80/149—1 x plant in plastic pot.
 80/150—1 x "brush-on" make up kit, 1 x 5 year diary.
 80/151—1 x large aluminium saucepan.
 80/152—Quantity motor vehicle parts Holden.
 80/153—1 x 20' garden hose.
 80/159—Y/m gents w/w Citron and band.
 80/165—Wallet, y/m Emperor w/w, w/m Lugran w/w, y/m Lucerne w/w, 1 x brooch, 2 x one pound notes.
 80/167—W/m gents w/w digital EEL.
 80/169—2 x fire extinguishers, 1 x cigarette lighter, 1 x Verix binoculars in case, 1 x flare, 1 x blanket.
 80/170—Numerous items jewellery including rings with stones, bracelets, necklaces.
 80/171—1 x car cassette player, 1 x car radio and cassette player, 1 x garden hose, 1 x garbage container, 1 x cane hanging basket, 1 x Vivitar camera.
 80/172—Suitcase and clothing, 12 x items tools, bag, padlock.
 80/177—1 x shirt, 1 x shawl, 1 x car louvre.
 80/178—Set farrier's tools in leather bag.
 80/180—Box assorted clothing, sundry items, 2 x chess draught sets, 2 x speakers, 2 x blankets, 5 x pillows, 1 x carpet square, 1 x rug, bedding, 1 x print in frame, 1 clock, 1 x TV aerial, 75 LP records, 1 x pair boots, 1 x Astor radio, 1 x electric fryer, 1 x GE iron, 1 x Air Master fan, 1 x ice bucket.
 80/181—2 x tool boxes and tools, 1 x case and tools.
 80/182—Y/m ring, tea towel, keys and key holder, brooch, cigarette lighter, w/m pendant.
 80/183—Quantity tools.
 80/187—1 x speaker, 1 x IDI car radio.
 80/188—4 x towels, 2 x combs, 1 x pair ear studs, 3 x bottles perfume.
 80/189—Quantity of tools, vehicle parts, oxy gauge, hose, hand piece, 7 x bottles wine, 15 x cassette tapes, electric fan, Sanyo cassette player, bag of tools, oxy hoses and hand-piece, gloves, esky.
 80/190—1 x box of 47 cassette tapes.
 80/191—2 x Bridgestone steel belted 60 x 10 in tyres on chrome rims, 1 x Pye B and W television, 1 x cash box, 2 x y/m chains.
 80/192—1 x pair sunglasses.
 80/193—10 x LP records, 1 x SP record.
 80/199—1 x gas bottle, box electrical connections, 1 x LP gas regulator and hose, 2 x sheep skin seat covers, 1 x bonnet scoop, 1 x pair boots, 1 x 12 volt battery, 1 x pair binoculars, 1 x Ford car radio, 1 x Wattmaster radio, cassette player, 82 cassette tapes, 4 x car speakers, tool box and tools, 1 x Skil electric drill and extension cord, 1 x spotlight.
 80/202—2 x mag rims fitted with Aquajet tyres ER70/14 and 10 x chrome wheel nuts.
 80/204—4 x bottles wine, 2 x bottles cocktail, 5 x cans spray paint, cassette box, 30 x cassette tapes, 1 x hydraulic jack, paint tubes, metal box, cigarette lighter, cassette player, radio, toilet items, 1 x foam cooler, camera, calculator, 10 cassette tapes, 3 x torches and batteries, 4 x blankets, clothing, bag, pipe, 2 x core plugs, wire tester, spanner, 1 x bottle brandy, 1 bottle gin.
 80/205—1 x Ricoh 35 camera and case, 2 x jerry cans, 1 x Tilley light, 1 x miner's lamp, 1 x grease gun, 1 x Primus stove, metal box and tools, 1 x spade, 1 x jack.
 80/206—7 x cassette tapes, 1 x wallet, 1 Kodak camera.
 80/208—1 x sports bag, 1 x box containing 12 items assorted jewellery, 1 x Sanyo radio-cassette player, 27 x cassette tapes, 1 x gent's w/w Citizen.
 80/209—Wallet, keys, pen.
 80/212—1 x single bed mattress.
 80/214—1 x school bag, 1 x Polaroid camera, clothing.
 80/215—1 x Sanyo radio.
 80/217—3 x foreign coins, 1 x Australian florin, 1 x Australian penny, 1 x Australian halfpenny.
 80/220—1 x packet tobacco, 1 x packet cigarettes, 1 x bicycle wheel, 3 x rubbish bins, 8 x cans soft drink, 1 x spanner.

- 80/221—1 x Sanyo CB radio, 1 x Thorn CB radio, 1 x torch, 1 x spanner, 1 x packet cigarettes, 2 x car radios, 1 x block and tackle, 1 x megaphone, paper towels.
- 80/222—1 x National radio-cassette player, 1 cassette tape.
- 80/223—1 x Super Snooper, 1 x Kodak camera, 1 x clock, 1 x tea towel, 1 x Citron w/w, 1 x set playing cards, macrami work, 1 x foreign bank note, 1 x calculator cover, 1 x shutter release, 3 x car louvres.
- 80/224—1 x AWA B and W television, 1 x Healing B and W television, both poor condition.
- 80/225—26 x cassette tapes.
- 80/230—2 x beer jugs, 2 x beer glasses, 21 x spark plugs.
- 80/232—Clothing.
- 80/233—1 x gent's w/m ring.
- 80/236—1 x pair louvres for vehicle, 2 x items tools, hose and container, 1 x shirt.
- 79/764—1 x bicycle.
- 80/702—Bicycle parts.
- 80/707—2 x bicycles.
- 80/708—1 x bicycle.
- 80/709—2 x bicycles.
- 80/723—1 x bicycle.
- 80/728—1 x bicycle.
- 80/730—1 x bicycle.
- 80/732—1 x bicycle.
- 80/743—1 x bicycle.
- 80/760—1 x bicycle, bicycle parts.
- 80/769A—1 x bicycle.
- 80/784—1 x bicycle.
- 80/789—1 x bicycle.
- 80/792—1 x bicycle.
- 80/808—7 x bicycles.
- 80/814—1 x bicycle.
- 80/821—5 x bicycles.
- 80/825—3 x bicycles.
- 80/831—3 x bicycles, 1 x bicycle frame.
- 80/857—1 x bicycle.
- 80/858—bicycle parts.
- 80/864—2 x bicycles, bicycle parts.
- 80/865—3 x bicycles.
- 80/871—1 x bicycle.
- 80/881—1 x bicycle.
- 80/882—bicycle parts.
- 80/885—1 x bicycle.
- 80/890—2 x bicycles.
- 80/910—2 x bicycles, bicycle parts.
- 80/914—2 x bicycles.
- 80/918—2 x bicycles, 1 x bicycle frame.
- 80/924—2 x bicycles.
- 80/939—4 x bicycles.
- 80/945—2 x bicycles.
- 80/957—3 x bicycles.
- 80/960—1 x bicycle.
- 80/976—1 x bicycle.
- 80/981—1 x bicycle.
- 80/999—1 x bicycle.
- 80/1005—2 x bicycles.
- 81/41—1 x bicycle.
- 81/50—1 x bicycle.
- 81/56—3 bicycles.
- 81/78—2 x bicycles.
- 81/95—1 x bicycle.
- 81/111—1 x bicycle.
- 80/977—Valiant sedan 1968—damaged.
- 80/978—Wolseley sedan 1954—damaged.
- 81/29—Holden van 1965—damaged.
- 81/88—Caravan, 3 berth, popup, aluminium 13 ft.
- 81/28—Motor cycle frame and front wheel.
- 80/736—1 x 8 ft. fibreglass sailing boat.
- 80/783—1 x 12 ft. two man kayak fibreglass—damaged.

CHILD WELFARE ACT 1947 (AS AMENDED).

Police Department,
Perth, 25 March 1981.

Ex. Co. No. 3512.

HIS Excellency, the Lieutenant Governor in Council, has approved the appointment of the Constitution of the Children's (Suspended Proceedings) Panel in accordance with section 71 (1) (b) of the Child Welfare Act, Amendment Act (No. 2) 1976.

Pursuant to the powers contained in section 71 (1) (b) of the above Act, it is hereby notified that the Commissioner of Police has authorised the following retired Police Officers:

James McCartney Woods,
Leslie Manuel Pages-Oliver,

to represent the Police as members of the Children's (Suspended Proceedings) Panel, to have effect as at the date of the *Government Gazette*.

F. W. R. BALCOMBE,
Assistant Commissioner (Crime).

TRANSFER OF LAND ACT 1893.

Application C17205.

TAKE notice that Heinz Josef Krahling of Toodyay, Farmer, made application to be registered under the Act as proprietor of an estate in fee simple in possession in the land situated at Julimar Road, Toodyay, being:

That portion of Avon Location 463 containing 6.569 hectares which is not comprised in diagram 57073.

All persons other than the applicant claiming any estate right title or interest in the above land and desiring to object to the application are required to lodge in this office on or before 18 May 1981 a caveat forbidding the land being brought under the operation of the Act.

T. C. McDONOUGH,
Registrar of Titles,
Office of Titles, Perth.

LAND ACT 1933.

Land Release.

Department of Lands and Surveys,
Perth, 3 April 1981.

Corres. No. 2524/79, V.2.

APPLICATIONS are invited under section 45A of the Land Act 1933 for the purchase in fee simple of the Cervantes lots shown in the Schedule for "Residential and Storage Purposes Associated with the Fishing Industry" at the purchase prices shown in the said schedule and subject to the following conditions:—

- (a) The purchaser shall erect on the lot purchased a residence to comply with Local Authority by-laws within four (4) years from the due date of the first instalment. If this condition has not been complied with in the time prescribed, the land may be absolutely forfeited together with all purchase money and fees that may have been paid. However, freehold title to the land may be applied for when a residence has been erected to "top plate height" stage, and is not less than 50% completed to the satisfaction of the Minister for Lands.

On payment of the first instalment of purchase money a license will be available, upon which a mortgage can be registered. A Crown Grant (freehold) will not issue until the purchaser has complied with the building condition. A holder of a licence may apply to the Minister for Lands for permission to transfer a licence.

- (b) A deposit of 10% of the purchase price is payable on application and the balance of purchase money shall be paid within twenty-four months of the date of approval of application by eight (8) equal quarterly instalments on the first days of January, April, July and October in each year. The first instalment of purchase money shall become due and payable on the first day of the quarter next

following the date of approval of application, the Crown Grant fee being payable with the last instalment of purchase money; Provided that amounts paid during the twelve months commencing on the first day of the quarter next following the date of approval of application shall be interest free but all monies outstanding after that period shall be subject to interest at a rate of 10% per annum calculated at quarterly rests on the balance outstanding at the end of the previous quarter. Such interest shall be due and payable with the prescribed instalment. Nothing shall prevent the balance of purchase money and fees being paid at an earlier date should the purchaser so desire but a Crown Grant shall not issue until the conditions under which the lots were made available for sale have been fulfilled.

- (c) The applicant shall be a *bona fide* fisherman and be the holder of a current Professional Fisherman's License and should this condition not be satisfied the License may be forfeited.
- (d) A limit of one lot per person, husband and wife being deemed to be one for the purpose of this condition.
- (e) The applicant is responsible for arrangement of power with the State Energy Commission.

Applications, accompanied by a deposit of 10% of the purchase price must be lodged at the Department of Lands and Surveys, Perth on or before Wednesday 6 May, 1981 together with a copy of Fishing and Boat Licenses and completed Land Board questionnaire.

All applications lodged on or before the closing date will be treated as having been received on that date, and if there are more applications than one for any lot the application to be granted will be decided by the Land Board.

Schedule.

Lot; Street; Area; Purchase Price; Deposit.

238; Catalonia; 1 416 m ² ; \$5 500; \$550.
239; Catalonia; 809 m ² ; \$4 000; \$400.
240; Catalonia; 809 m ² ; \$4 000; \$400.
241; Catalonia; 809 m ² ; \$4 000; \$400.
242; Catalonia; 809 m ² ; \$4 000; \$400.
243; Catalonia; 809 m ² ; \$4 000; \$400.
244; Catalonia; 809 m ² ; \$4 000; \$400.
619; Aragon; 964 m ² ; \$5 000; \$500.
620; Aragon; 982 m ² ; \$5 000; \$500.
621; Brown; 1 262 m ² ; \$7 000; \$700.
622; Brown; 1 214 m ² ; \$7 000; \$700.
623; Brown; 1 214 m ² ; \$7 000; \$700.
624; Brown; 1 214 m ² ; \$7 000; \$700.
625; Brown; 1 214 m ² ; \$7 000; \$700.
626; Brown; 1 214 m ² ; \$7 000; \$700.
627; Brown; 1 214 m ² ; \$7 000; \$700.
628; Brown; 1 214 m ² ; \$7 000; \$700.
629; Toledo; 809 m ² ; \$6 000; \$600.
630; Toledo; 809 m ² ; \$6 000; \$600.
631; Toledo; 791 m ² ; \$6 250; \$625.
632; Toledo; 1 078 m ² ; \$6 750; \$675.
633; Toledo; 1 093 m ² ; \$6 500; \$650.
634; Brown; 1 214 m ² ; \$7 000; \$700.
635; Brown; 1 296 m ² ; \$7 000; \$700.
636; Brown; 1 376 m ² ; \$7 000; \$700.
637; Brown; 1 417 m ² ; \$7 000; \$700.
638; Brown; 1 416 m ² ; \$7 000; \$700.
639; Brown; 1 416 m ² ; \$7 000; \$700.
640; Brown; 1 416 m ² ; \$7 000; \$700.
641; Green; 944 m ² ; \$6 250; \$625.
642; Green; 944 m ² ; \$6 250; \$625.
643; Green; 926 m ² ; \$6 500; \$650.

(Plans Cervantes 04.24, 04.25 & 05.25 (Brown, Aragon, Toledo, Green and Catalonia Streets).)

B. L. O'HALLORAN,
Under Secretary for Lands.

APPLICATION FOR LEASING.

Department of Lands and Surveys,
Perth, 3 April 1981.

Corres. No. 386/72.

APPLICATIONS are invited under section 117 of the Land Act 1933 for the leasing of Wannoo Lot 4 containing an area of 1.078 1 hectares for the purpose of "Caravan Park" for a term of 21 years at a rental of \$200.00 per annum.

Intending applicants shall submit with their application an outline plan drawn to scale, showing development proposed within two years from the date of approval of the application.

The Minister for Lands reserves the right to refuse any application on the grounds that no development plans were submitted with such application or that the proposed development is inadequate or unsuitable.

Neither the Government nor the Local Authority shall be responsible for providing additional services to the site.

On completion of a Caravan Park in accordance with the Caravan Park Model by-laws to the satisfaction of the Minister for Lands the lessee may surrender his lease in order that the land may be made available in freehold. In this regard it is advised that the lessee should not anticipate freehold title before providing full details of completed development for departmental examination and approval. The price for the land shall be \$2 500.00 and shall remain valid for a period of 3 years from the date of this notice.

The land is made available for leasing subject to the following conditions:—

- (1) The land shall not be used for any purpose other than Caravan Park without the prior approval in writing of the Minister for Lands.
- (2) The rent shall be subject to reappraisal at the end of the third year and each successive three year period thereafter.
- (3) The lessee shall not without the previous consent in writing of the Minister for Lands assign, transfer, mortgage, sublet or part with the possession of the demised land.
- (4) The land shall be occupied and used by the lessee for the purpose specified within nine (9) months of the commencement of the lease and thereafter will be continuously so used to the satisfaction of the Minister.
- (5) The lessee shall commence construction within nine (9) months and thereafter continue construction and complete and operate the works within two (2) years from the date of the commencement of the lease.
- (6) All buildings, erections, paving, drainage and other works shall be to the approval of the Local Authority and the lessee shall perform, discharge and execute all requisitions and works unto the demised land as are or may be required by any local or public authority operating under any statute by-law or regulation.
- (7) Development must be in accordance with the Caravan Park Model By-laws under the Local Government Act and to the satisfaction of the Shire of Shark Bay.
- (8) The lessee shall maintain existing and future improvements to the satisfaction of the Minister for Lands.
- (9) The lessee shall indemnify the Minister against all claims for damage to property or persons arising from the use of the land.
- (10) The Minister or his representative may enter the land for inspection at any reasonable time.
- (11) Compensation shall not be payable to the lessee in respect of any improvements effected by him on the demised land and remaining thereon at the expiration or earlier determination of the lease.
- (12) It shall be lawful for the lessee at any time within the three calendar months immediately following the expiration of the term or earlier determination of the lease, to take down, remove and carry away any buildings, structures, improvements and plant the property of the lessee.

- (13) On determination of the lease, the lessee shall fill in, consolidate and level off any unevenness, excavation or hole caused by him during the term of the lease or by removal of his improvements and shall leave the demised land in a clean, neat and tidy condition to the satisfaction of the Minister for Lands and shall remove any or all waste matter as required by the Minister.

A person in the employ of the State must apply through the Under Secretary for Lands for the Governors permission to hold this land. Written approval of the Permanent Head concerned should accompany such application.

Applications must be lodged at the Department of Lands and Surveys, Perth, on or before Wednesday, 6 May 1981 accompanied by a deposit of \$130.00 together with the required plan and completed Land Board Questionnaire.

All applications lodged on or before that date will be treated as having been received on the closing date, and if there are more applications than one for the lot, the application to be granted will be decided by the Land Board.

(Plan Yaringa 1:250 000.)

B. L. O'HALLORAN,
Under Secretary for Lands.

TOWN PLANNING AND DEVELOPMENT ACT 1928 (AS AMENDED).

Notice that a Town Planning Scheme Amendment has been Prepared and is Available for Inspection.

City of Canning Town Planning Scheme
No. 16—Amendment No. 216.

T.P.B. 853/2/16/18, Pt. 216.

NOTICE is hereby given that the Council of the City of Canning in pursuance of its powers under the Town Planning and Development Act 1928 (as amended) has prepared a Town Planning Scheme amendment for the purpose of rezoning Lots 560, 561 and 572 Canning Loc 2, Nos. 1080-82, Albany Highway (to Norman Street) Welshpool from "GR4" to "GR5 and Highway—Access Not Controlled".

All plans and documents setting out and explaining the amendment have been deposited at Council Offices, 1317 Albany Highway, Cannington and will be open for inspection without charge during the hours of 9.00 a.m. to 4.00 p.m. on all days of the week except Saturdays, Sundays and Public Holidays until and including 8 May 1981.

The plans and documents have also been deposited at the office of the Town Planning Department, Perth and will similarly be open for inspection for the same period between the hours of 10 a.m. and 4 p.m.

Any person who desires to make a submission on the amendment should make the submission in writing in the form prescribed by the regulations and lodge it with the Town Clerk, Canning City Council, 1317 Albany Highway, Cannington 6107 on or before 8 May 1981.

N. I. DAWKINS,
Town Clerk.

TOWN PLANNING AND DEVELOPMENT ACT 1928 (AS AMENDED).

Advertisement of Approved Town Planning
Scheme Amendment.

City of Canning Town Planning Scheme
No. 16—Amendment No. 222.

T.P.B. 853/2/16/18, Pt. 222.

IT is hereby notified for public information, in accordance with section 7 of the Town Planning and Development Act 1928 (as amended) that the Minister for Urban Development and Town Planning approved the City of Canning Town Planning Scheme Amendment on 20 March 1981 for the purpose of amending the Scheme Text by deleting existing Clause 20A (2) and by substituting the following new Clause 20A (2):—

- (2) The permission given by the Council pursuant to this clause shall be for a period not extending beyond twelve months from the date upon which, as decided by the Council, the land is close enough to essential services to be capable of development for its zoned use.

E. CLARK,
Mayor.
N. I. DAWKINS,
Town Clerk.

TOWN PLANNING AND DEVELOPMENT ACT 1928 (AS AMENDED).

Advertisement of Approved Town Planning
Scheme Amendment.

City of Cockburn District Zoning Scheme
No. 1—Amendment Nos. 97 and 103.

T.P.B. 853/2/23/5, Pts. 97 and 103.

IT is hereby notified for public information, in accordance with section 7 of the Town Planning and Development Act 1928 (as amended) that the Minister for Urban Development and Town Planning approved the City of Cockburn Town Planning Scheme Amendment on 20 March 1981 for the purpose of:—

Amendment No. 97: Rezoning portion of Cockburn Sound Location 334 Yangebup from "Residential and Rural" to "Multi Residential" and portions of Jandakot Agricultural Area Lot 299 Yangebup from "Residential" to "Multi Residential" as depicted on the amending plan 12.89 adopted by Council on 9 April 1980 and approved by the Minister for Urban Development and Town Planning.

Amendment No. 103: Rezoning Lots 91, 92 and 93 Cockburn Sound Location 10 Rockingham Road, Hamilton Hill from "Residential Zone" to "Office Zone" as depicted on plan 12.95.

D. F. MIGUEL,
Mayor.
R. W. BROWN,
Acting Town Clerk.

TOWN PLANNING AND DEVELOPMENT ACT 1928 (AS AMENDED).

Advertisement of
Approved Town Planning Scheme Amendment.

City of Gosnells Town Planning Scheme No. 1—
Amendment No. 145.

T.P.B. 853/2/25/1, Pt. 145.

IT is hereby notified for public information, in accordance with section 7 of the Town Planning and Development Act 1928 (as amended) that the Minister for Urban Development and Town Planning approved the City of Gosnells Town Planning Scheme Amendment on 23 March 1981 for the purpose of rezoning Lots 21-24 corner of Attfield and Blackburn Streets, Maddington from "Residential A" to "Offices".

R. D. HARRIS,
Mayor.
G. WHITELEY,
Town Clerk.

TOWN PLANNING AND DEVELOPMENT ACT 1928 (AS AMENDED).

Advertisement of
Approved Town Planning Scheme Amendment.

City of Nedlands Town Planning Scheme No. 1—
Amendment No. 87.

T.P.B. 853/2/8/1, Pt. 87.

IT is hereby notified for public information, in accordance with section 7 of the Town Planning and Development Act 1928 (as amended) that the Minister for Urban Development and Town Planning approved the City of Nedlands Town Planning Scheme Amendment on 20 March 1981 for the purpose of rezoning Lots 1 and 2 Lisle Street (corner Beecham

Road) from "Residential A" to "Residential B" and adding a new clause to the Scheme Text after Clause 3.9

3.10 On Lots 1 and 2 Lisle Street the provision of the table relating to the side setback for a Residential "B" zone (Clause 3.2) is reduced to 1.5 metres.

The only permitted use on this site is Aged Persons Homes.

D. C. CRUICKSHANK,
Mayor.

N. G. LEACH,
Town Clerk.

TOWN PLANNING AND DEVELOPMENT ACT
1928 (AS AMENDED).

Notice that a Town Planning Scheme Amendment has been Prepared and is Available for Inspection.

City of South Perth Town Planning Scheme No. 2
—Amendment No. 39.

T.P.B. 853/2/11/2, Pt. 39.

NOTICE is hereby given that the Council of the City of South Perth in pursuance of its powers under the Town Planning and Development Act 1928 (as amended) has prepared a Town Planning Scheme amendment for the purpose of rezoning Lot 217 corner of Canning Highway and Lockhart Street from "Special Service Station Zone" to "Commercial 'G' Zone".

All plans and documents setting out and explaining the amendment have been deposited at Council Offices, Sandgate Street, South Perth and will be open for inspection without charge during the hours of 8.45 a.m. to 4.00 p.m. on all days of the week except Saturdays, Sundays and Public Holidays until and including 8 May 1981.

The plans and documents have also been deposited at the office of the Town Planning Department, Perth and will similarly be open for inspection for the same period between the hours of 10 a.m. and 4 p.m.

Any person who desires to make a submission on the amendment should make the submission in writing in the form prescribed by the regulations and lodge it with the Town Clerk, South Perth City Council, Sandgate Street, South Perth on or before 8 May 1981.

P. A. BENNETTS,
Town Clerk.

TOWN PLANNING AND DEVELOPMENT
ACT 1928 (AS AMENDED).

Advertisement of Approved Town Planning
Scheme Amendment.

Town of Armadale Town Planning
Scheme No. 1—Amendment No. 150.

T.P.B. 853/2/22/1, Pt. 150.

IT is hereby notified for public information, in accordance with section 7 of the Town Planning and Development Act 1928 (as amended) that the Minister for Urban Development and Town Planning approved the Town of Armadale Town Planning Scheme Amendment on 20 March 1981 for the purpose of rezoning Lot 224 Ypres Road, Kelmscott from "Single Residential SR3" to "Special Use—Veterinary Consulting Rooms" and including the Sub-classification 15.1 "Special Use—Veterinary Consulting Rooms" within Part III Clause 3.2 of the Scheme Text and within the Legend Sheet of the Scheme Maps.

I. K. BLACKBURN,
Mayor.

A. E. RASMUSSEN,
Town Clerk.

TOWN PLANNING AND DEVELOPMENT ACT
1928 (AS AMENDED).

Advertisement of
Approved Town Planning Scheme Amendment.
Town of Cottesloe Town Planning Scheme—
Amendment No. 12.

T.P.B. 853/2/3/4, Pt. 12.

IT is hereby notified for public information, in accordance with section 7 of the Town Planning and Development Act 1928 (as amended) that the Minister for Urban Development and Town Planning approved the Town of Cottesloe Town Planning Scheme Amendment on 23 March 1981 for the purpose of rezoning Part of Lot 8 and Lots 9, 10 and 11 being portion of Swan Location 349, corner of Stirling Highway and Jarrad Street, Cottesloe from "Service Station" to "Town Centre" as depicted on the amending plan adopted by Council on 23 July 1980 and approved by the Minister for Urban Development and Town Planning.

J. ANDERSON,
Mayor.

R. PEDDIE,
Town Clerk.

TOWN PLANNING AND DEVELOPMENT
ACT 1928 (AS AMENDED).

Advertisement of Approved Town Planning
Scheme Amendment.

Shire of Bayswater Town Planning
Scheme No. 13—Amendment No. 85.

T.P.B. 853/2/14/16, Pt. 85.

IT is hereby notified for public information, in accordance with section 7 of the Town Planning and Development Act 1928 (as amended) that the Minister for Urban Development and Town Planning approved the Shire of Bayswater Town Planning Scheme Amendment on 25 March 1981 for the purpose of rezoning Lots 71, 36, 35, 34, 33, 32 between Widgee Road and Benara Road and Lots 78, 1, 2, 3, 4, 5, 6 Pt 7 between Benara Road and Deschamp Road, North Morley from "Rural" to "Residential, Multi-Residential GR4, Business, Public Buildings, Public Open Space, and Drainage" in accordance with Shire of Bayswater Town Planning Scheme No. 17—Benara West Development Scheme and as depicted on the amending plan adopted by Council on 8 August 1979 and approved by the Minister for Urban Development and Town Planning.

N. E. DAVIS,
President.

K. B. LANG,
Shire Clerk.

TOWN PLANNING AND DEVELOPMENT
ACT 1928 (AS AMENDED).

Advertisement of Approved Town Planning
Scheme Amendment.

Shire of Esperance Town Planning
Scheme No. 16—Amendment No. 49.

T.P.B. 853/11/6/11, Pt. 49.

IT is hereby notified for public information, in accordance with section 7 of the Town Planning and Development Act 1928 (as amended) that the Minister for Urban Development and Town Planning approved the Shire of Esperance Town Planning Scheme Amendment on 25 March 1981 for the purpose of amending Clause 3.6 of the Scheme Text by deleting the words "on the Scheme Map and".

M. J. ANDRE,
President.

E. L. CHOWN,
Shire Clerk.

TOWN PLANNING AND DEVELOPMENT
ACT 1928 (AS AMENDED).

Notice that a Town Planning Scheme Amendment has been Prepared and is Available for Inspection.

Shire of Esperance Town Planning Scheme
No. 16—Amendment No. 52.

T.P.B. 853/11/6/11, Pt. 52.

NOTICE is hereby given that the Esperance Shire Council in pursuance of its powers under the Town Planning and Development Act 1928 (as amended) has prepared a Town Planning Scheme amendment for the purpose of rezoning Lot 110 Location 50, corner of Pink Lake Road and Milner Streets from "Special Use—Funeral Parlour" to "Shopping and Central Business" and amending the Schedule of Special Use Zones accordingly.

All plans and documents setting out and explaining the amendment have been deposited at Council Offices, Windich Street, Esperance and will be open for inspection without charge during the hours of 10.00 a.m. to 4.00 p.m. on all days of the week except Saturdays, Sundays and Public Holidays until and including 1 May 1981.

The plans and documents have also been deposited at the office of the Town Planning Department, Perth and will similarly be open for inspection for the same period between the hours of 10 a.m. and 4 p.m.

Any person who desires to make a submission on the amendment should make the submission in writing in the form prescribed by the regulations and lodge it with the Shire Clerk, Esperance Shire Council, P.O. Box 507, Esperance 6450 on or before 1 May 1981.

E. L. CHOWN,
Shire Clerk.

TOWN PLANNING AND DEVELOPMENT
ACT 1928 (AS AMENDED).

Advertisement of Approved Town Planning
Scheme Amendment.

Shire of Serpentine-Jarrahdale Town Planning Scheme
No. 1—Amendment No. 27.

T.P.B. 853/2/29/1, Pt. 27.

IT is hereby notified for public information, in accordance with section 7 of the Town Planning and Development Act 1928 (as amended) that the Minister for Urban Development and Town Planning approved the Shire of Serpentine-Jarrahdale Town Planning Scheme Amendment on 20 March 1981 for the purpose of amending the Special Provisions of the Scheme Text by altering the uses permitted in Special Rural Zone Areas 1, 2, 3, 4 and 6. The full text of the Amendment is set out in the Schedule annexed hereto.

H. C. KENTISH,
President.

L. E. MANN,
Shire Clerk.

Schedule.

Town Planning and Development Act 1928
(as Amended).

Shire of Serpentine-Jarrahdale Town Planning Scheme
No. 1—Amendment No. 27.

THE Serpentine-Jarrahdale Shire Council under and by virtue of the powers conferred upon it in that behalf by the Town Planning and Development Act 1928 (as amended) and the Metropolitan Region Town Planning Scheme Act 1959 (as amended), hereby amends the above Town Planning Scheme by:—

- (1) Changing the Special Provisions referring to Special Rural Zone Areas 1, 2, 3 and 6 by deleting from Clause 2, subclause (c), and inserting the new subclauses (c) and (d) as follows:—

- (i) (c) The following uses are not permitted unless approval is given by Council

(AA) Rural Use.

- (ii) (d) All other uses not mentioned in (a), (b) and (c) are not permitted (x).

- (2) Changing the Special Provisions referring to Special Rural Zone Area No. 6 as follows:—

- (i) By deleting the uses "Rural" and "Stables" from subclause 2 (b).

- (3) Changing the Special Provisions referring to Special Rural Zone Area No. 4 by deleting from Clause 2, subclause (b) and inserting new subclauses (b) (c) and (d) as follows:—

- (i) (b) The following uses are not permitted unless approval is given by Council

(AA) Rural Use (excluding Stables).

- (ii) (c) The following uses are not permitted unless the special approval is granted by the Council "SP"—

Duplex
Home Occupation
Private Recreation.

- (iii) (d) All other uses not mentioned in (a), (b) and (c) are not permitted (x).

TOWN PLANNING AND DEVELOPMENT
ACT 1928 (AS AMENDED).

Notice that a Town Planning Scheme Amendment has been Prepared and is Available for Inspection.

Shire of Swan Town Planning Scheme
No. 1—Amendment Nos. 94 and 98.

T.P.B. 853/2/21/1, Pts. 94 and 98.

NOTICE is hereby given that the Swan Shire Council in pursuance of its powers under the Town Planning and Development Act 1928 (as amended) has prepared a Town Planning Scheme amendment for the purpose of:—

Amendment No. 94—Rezoning Pt. Lots 67, 68 and 69 East Street, Guildford from "Residential" to "Special Site—Craftsmans Village" and including the area in Appendix C of the Scheme Text.

Amendment No. 98—Redefining the extent of the Midland Central Business District to accord with several recent Town Planning Studies which have related to the Midland Sub-Regional Centre.

All plans and documents setting out and explaining the amendment have been deposited at Council Offices, Great Northern Highway Middle Swan and will be open for inspection without charge during the hours of 9.00 a.m. to 4.30 p.m. on all days of the week except Saturdays, Sundays and Public Holidays until and including 3 July 1981 (Amendment No. 94) and 24 April 1981 (Amendment No. 98).

The plans and documents have also been deposited at the office of the Town Planning Department, Perth and will similarly be open for inspection for the same period between the hours of 10 a.m. and 4 p.m.

Any person who desires to make a submission on the amendment should make the submission in writing in the form prescribed by the regulations and lodge it with the Shire Clerk, Swan Shire Council, P.O. Box 196, Midland 6056 on or before 3 July 1981 (Amendment No. 94) and 24 April 1981 (Amendment No. 98).

R. S. BLIGHT,
Acting Shire Clerk.

TOWN PLANNING AND DEVELOPMENT ACT
1928 (AS AMENDED).

Advertisement of Approved Town Planning Scheme.

City of Melville Town Planning Scheme No. 4.
Melville City Centre Guided Development Scheme.

T.P.B. 853/2/17/11.

IT is hereby notified for public information, in accordance with section 7 of the Town Planning and Development Act, 1928 (as amended) that the Minister for Urban Development and Town Planning approved the City of Melville Town Planning Scheme No. 4—Melville City Centre Guided Development Scheme on the 20th January, 1981—the Scheme Text of which is published as a Schedule annexed hereto.

J. F. HOWSON,
Mayor.

R. H. FARDON,
Town Clerk.

Schedule.

City of Melville.

Town Planning Scheme No. 4.

Melville City Centre Guided Development Scheme.

THE City of Melville under and by virtue of the powers conferred upon it in that behalf by the Town Planning and Development Act, 1928 (as amended), hereby makes the following Town Planning Scheme.

Contents.

	Clause No.
Citation	1
Responsible Authority	2
Interpretation	3
Maps ..	4
Scheme Area	5
General Objects	6
Zoning	7
Subdivision ..	8-10
Realignment of Davy Street	11-14
Pedestrian Accessways	15-17
Roads Adjacent to Civic Centre	18
Sewerage, Drainage and Water Supply Works	19-20
Civic Square ..	21
Other Works	22
Public Open Space ..	23-24
Development	25-26
Building Height and Form ..	27-28
Exterior Design of Buildings	29
Landscaping	30
Parking	31
Signs ..	32
Access to Almondbury Road	33
Pedestrian Crossing in Marmion Street	34
Staging of Development	35-36
Scheme Costs	37
Payment of Scheme Costs ..	38-42
Estimate of Scheme Costs ..	43
Arbitration	44
Powers and Authorities of Council	45-47
Claims for Compensation	48
Betterment	49
Cessation of Scheme	50

Citation.

1. This Town Planning Scheme may be cited as City of Melville Town Planning Scheme No. 4—Melville City Centre Guided Development Scheme.

Responsible Authority.

2. The authority responsible for enforcing the observance of this Scheme is the City of Melville.

Interpretation.

3. (1) In this Scheme unless the context otherwise requires:—

“Act” means the Town Planning and Development Act, 1928;

“Board” means the Town Planning Board of Western Australia;

“clause” means a clause of the Scheme;

“completion of development” in relation to land means the date of practical completion of the development certified by an architect or designer or the date upon which a building or structure comprising or forming part of the development is occupied or used, whichever is the earlier;

“Council” means the City of Melville;

“final approval of the Board” in relation to the subdivision or amalgamation of land means the approval of the Board to a plan or diagram of survey depicting the lot or lots created or to be created by the subdivision or amalgamation of the land after all (if any) conditions imposed by the Board have been carried out;

“Scheme” means this Town Planning Scheme;

“Scheme Area” means the area defined in Clause 5;

“Scheme Costs” means the costs described in Clause 37;

“Stage of Development” means stage of development depicted on the Staging Map;

“sub-clause” means a sub-clause of the clause in which the term is used.

(2) Unless otherwise provided herein or unless the context otherwise requires words and expressions not defined in sub-clause (1) have the meanings respectively assigned to them by the Act.

(3) Headings are for reference purposes only and shall not affect the construction of this Scheme Text.

Maps.

4. The following maps are attached to and form part of the Scheme—

(1) Land Use Map.

(2) Scheme Maps:—

(a) Concept Plan.

(b) Building Layout and Form Map.

(c) Building Use Map.

(d) Landscape Map.

(e) Pedestrian System Map.

(f) Staging Map.

(g) Subdivision Guide Map.

Scheme Area.

5. The Scheme applies to the whole of the land contained within the inner edge of a broken black line on the Land Use Map.

General Objects.

6. The general objects of the Scheme are:—

(a) to facilitate and encourage the progressive subdivision and development of the land within the Scheme Area for commercial, public and recreational purposes;

(b) to control the development and use of land and buildings within the Scheme Area in accordance with the Scheme Maps;

(c) to control the form, colour, texture, bulk and exterior design of buildings within the Scheme Area in order to ensure architectural compatibility with the existing Civic Centre and Shopping Centre buildings therein;

(d) to protect the amenity of the residential area on the northern side of Almondbury Road;

- (e) to provide a pedestrian system throughout the Scheme Area free of vehicles;
- (f) to provide, develop and maintain landscaped areas throughout the Scheme Area;
- (g) to control advertisement signs in the Scheme Area;
- (h) to rationalise the road system adjacent to the Civic Centre;
- (i) to make provision for other matters which are necessary or incidental to town planning;
- (j) to improve and secure the amenity, health and convenience of the Scheme Area;
- (k) to make provision for the apportionment of Scheme Costs amongst owners in an equitable manner.

Zoning.

7. It is intended that the land within the Scheme Area will be zoned in a manner whereby the uses shown on the Building Use Map will be permitted with the approval of the Council.

Subdivision.

8. As and when owners of land within the Scheme Area subdivide or amalgamate their land the subdivision or amalgamation shall be according to a plan which will be capable of forming part of the overall plan of subdivision for the Scheme Area shown on the Subdivision Guide Map.

9. The Council may with the consent of the Town Planning Board permit departures from the design shown on the Subdivision Guide Map if it considers the proposed subdivisional design to be of a similar standard to that shown but no departure from the design shown on the Subdivision Guide Map shall be permitted if in the opinion of the Council it would impede the subdivision of the Scheme Area as a whole.

10. An owner of land who desires to subdivide or amalgamate his land either alone or in conjunction with another owner or owners shall submit to the Council and to the Board a plan of subdivision or amalgamation in conformity with the Subdivision Guide Map with such modifications as are permitted by the Council under Clause 9 hereof.

Realignment of Davy Street.

11. (1) The portion of Davy Street shown on the Subdivision Guide Map as the portion to be closed shall be closed as the development of the land proceeds and as that portion is no longer required.

(2) When the portion of Davy Street referred to in sub-clause (1) has been closed the land comprised in that portion shall be used for the purpose shown on the Scheme Maps and shall (if appropriate) be vested in the owner of the adjoining land for that purpose free of cost if the owner has made the land required for the realignment of Davy Street available or has agreed to do so in a manner satisfactory to the Council.

12. The owner of the land comprising the realignment of Davy Street shown on the Scheme Maps, having signified to the Council its willingness to do so, shall when subdividing, amalgamating or developing his land make the land required for the realignment of Davy Street available for that purpose and shall pay the costs of relocation of water, sewerage, drainage, electricity, telephone and other services and the costs of the construction and drainage of that street.

13. The Council may from time to time as and when it thinks fit acquire by purchase, exchange or resumption or partly by one method and partly by another the whole or any portion of the land required for the realignment of Davy Street and may construct and drain Davy Street thereon and may recover from the owner liable therefor all compensation and other costs consequent upon the acquisition of the land and all costs of construction and drainage of the road.

14. If the owner referred to in Clause 12 subdivides, amalgamates or develops his land and he or his predecessors in title have claimed or been paid compensation by reason of the resumption by the Council of the land required for the realignment of Davy Street he shall

before the final approval by the Town Planning Board to his plan of subdivision or amalgamation or the approval of the Council to the development, as the case may be, release the Council from the compensation claimed or repay to the Council the amount of compensation paid by it to him or his predecessors in title as the case may be.

Pedestrian Accessways.

15. The Pedestrian System Map shows the proposed pedestrian accessways within the Scheme Area.

16. Each owner shall when developing his land make land available for the pedestrian accessways and prior to the completion of the development construct and drain the pedestrian accessways within the land owned by him shown on the Pedestrian System Map at his expense and to the satisfaction of the Council.

17. The Council may construct and drain any pedestrian accessways and acquire the land necessary for that purpose and if the Council does so prior to the subdivision, amalgamation or development of the lands adjoining the pedestrian accessway the costs of the construction and drainage of the pedestrian accessway and all compensation and other costs consequent upon the acquisition of the land shall be paid to the Council by each owner of land in accordance with the foregoing provisions upon the final approval of the Town Planning Board to the subdivision or amalgamation of his land, upon the approval of the Council to the development or after having been served with not less than three months notice from the Council calling upon him to make such payment whichever first happens.

Roads Adjacent to Civic Centre.

18. (1) The Council shall redesign the roads adjacent to the Civic Centre in accordance with the Concept Plan and carry out all necessary works in order that those roads will be constructed and improved accordingly.

(2) The Council shall pay the costs of carrying out the works referred to in sub-clause (1).

Sewerage, Drainage and Water Supply Works.

19. (1) All sewerage works, drainage works and water supply works necessary for the proper drainage of the Scheme Area and the connection of the land therein to drains, to a sewer and to water mains shall at the appropriate times be carried out by or at the cost of the owner of the land served by those works.

(2) Each owner shall also pay the cost of the connection within his lot to the sewerage service.

20. The Council may acquire any land it considers necessary for sewerage, water supply or drainage services, may set aside land for drainage sumps, compensating basins and other works and carry out or arrange for sewerage, drainage and water supply works to be carried out.

Civic Square.

21. The owner of Lot 15 on Plan 9417 shall at his own expense carry out and complete the construction, drainage and landscaping of a Civic Square adjacent to the Civic Centre as shown on the Concept Plan prior to the expiration of the first stage of development or within such further time as the Council approves in writing and to the reasonable satisfaction of the Council.

Other Works.

22. In addition to the foregoing the following works or those that the Council considers necessary, shall be carried out—

- (a) the construction of public lavatories contiguous to and associated with the proposed buildings shown on the Concept Plan;
- (b) the provision of underground electric power-lines.

Public Open Space.

23. It is intended that the portion of public open space shown on the Subdivision Guide Map will be cancelled and the land vested in the Council as the owner of Lot 13 the subject of Diagram 36592 and used for the purpose shown on the Building Use Map.

24. It is intended that the land shown as Public Open Space on the Subdivision Guide Map which is owned by the Council will be reserved for Public Open Space.

Development.

25. (1) Subject to sub-clause (2) when carrying out any development thereon each owner of land within the Scheme Area shall comply with the requirements and provisions of Clauses 26 to 33.

(2) The Council may permit departures from the provisions of the Scheme if it considers the proposed development to be of a similar standard to that required by the Scheme but no departure shall be permitted if in the opinion of the Council it would impede the subdivision or development of the Scheme Area as a whole.

26. (1) The Building Use Map indicates an acceptable method of development of the Scheme Area.

(2) A person shall not carry out any development on land within the Scheme Area unless the development is for the use and purpose shown on the Building Use Map.

Building Height and Form.

27. A person shall not without the written approval of the Council erect a building on land within the Scheme Area having a number of storeys which exceeds the number of storeys shown on the Building Layout and Form Map.

28. A person shall not without the written approval of the Council erect or commence to erect a building on land within the Scheme Area unless the layout, design and dimensions of the building conform to those shown on the Building Layout and Form Map.

Exterior Design of Buildings.

29. A person shall not erect or commence to erect a building on land within the Scheme Area unless in addition to any other approval required by law, plans and details of the design, the form, colour and texture of the building have been submitted to and approved by the Council and having regard to the compatibility of the proposed building with the existing shopping centre and Civic Centre in the Scheme Area and the preservation of local amenities, the Council may grant or refuse approval.

Landscaping.

30. A person who carries out any development on land within the Scheme Area shall within three months after the completion of the development:—

- (a) carry out and complete landscaping substantially in accordance with the Landscape Map;
- (b) cause the colour and form of the landscaping to be in harmony with and enhance the building on or to be erected on the site;
- (c) cause the landscaping to be designed by a qualified landscape architect or other person acceptable to Council and to be carried out and completed in accordance with that design.

Parking.

31. A person who carries out any development on land within the Scheme Area shall cause all car parking areas shown on the Concept Plan within the site to be constructed, paved, drained and marked within three months after the completion of the development substantially in accordance with that Plan.

Signs.

32. A person shall not without the prior approval of the Council erect or maintain an advertisement, advertising hoarding, illuminated sign or other advertising device or erection or other disfigurement on any land or building within the Scheme Area other than a sign that complies with the by-laws of the Council for the time being in force indicating the trading name of the occupier and the nature of the business carried on upon the land or an advertisement, advertising hoarding, illuminated sign or other advertising device or erection or other disfigurement lawfully erected prior to the coming into operation of the Scheme.

Access to Almondbury Road.

33. No vehicular access to or egress from Lot 15 on Plan 9417 from or to Almondbury Road is permitted.

Pedestrian Crossing on Marmion Street.

34. The owner of part of Lot 6 on Plan 7157 shall, in addition to the foregoing requirements, when carrying out any development thereon or prior to the final approval of the Board to a subdivision or amalgamation thereof, whichever is the earlier, construct or cause to be constructed a pedestrian crossing on Marmion Street in a position and to specifications approved by the Council but at the same level as that street or, if the Council so agrees, pay to the Council the estimated costs thereof.

Staging of Development.

35. (1) It is proposed that the development shall be carried out in the three stages depicted on the Staging Map;

(2) The dates for commencement and completion of each of those stages are estimates only and any owner of land in the Scheme Area may apply, from time to time to the Council for its consent to the extension of those dates or any of them and the Council shall not withhold that consent if the owner demonstrates that there are reasonable grounds for the extension sought;

(3) If any dispute arises as to whether there are reasonable grounds for an extension under sub-clause (2) of this clause that dispute shall be referred to arbitration under Clause 44 of the Scheme.

36. Without limiting the generality of Clause 45, the Council may enter into agreements with owners of land within the Scheme Area in order to ensure the progressive development of land within the Scheme Area in accordance with the Staging Map.

Scheme Costs.

37. (1) The costs or estimated costs of the following items are the Scheme Costs:—

- (a) the costs of preparation and administration of the Scheme including an amount to reimburse the Council for all overhead, supervision and management costs it may incur in the preparation and implementation of the Scheme and including all legal costs, planning costs, payments to planning consultants, engineering consultants and other professional consultants and valuation costs;
- (b) the costs (if any) to the Council of carrying out the works mentioned in Clauses 13, 17, 19, 20 and 22;
- (c) all compensation payable and all costs and expenses of determining and settling compensation.
- (d) all interest accruing from time to time on moneys borrowed by the Council for the purposes of the Scheme with the exception of moneys borrowed for the purposes of Clause 18;
- (e) all other costs and expenses which the Council is required to meet in order to implement and complete the Scheme.

(2) The Council shall maintain full and complete records of all Scheme Costs.

(3) The Council shall deliver to each owner of land within the Scheme Area at least once in each period of three months during the first stage of development and annually thereafter a full and complete statement of costs attributable to the Scheme and shall if reasonably required by an owner provide reasons for the inclusion of any items as Scheme costs.

(4) The inclusion of any item within Scheme costs and the detailed costing thereof shall where any dispute arises between owners and the Council be referred to arbitration and pursuant to Clause 44 hereof.

Payment of Scheme Costs.

38. The Council may apportion the Scheme Costs among owners of land (other than the Council) in the proportions that it considers fair and equitable having regard to the benefit derived by them respectively from the carrying out of the works to which each particular item of Scheme Costs relates, but if the Council considers that the whole or substantially the whole of the benefit is derived by one owner it may require that owner to pay the whole of the Scheme Costs of any one or more items.

39. The Council shall give written notice to each owner of the amount of Scheme Costs payable by him and the manner in which the Scheme Costs have been apportioned amongst the owners of land within the Scheme Area.

40. An owner may object to the apportionment of the Scheme Costs within thirty days after the service of the notice referred to in Clause 39 hereof.

41. If one or more owners object to the apportionment of the Scheme Costs and the Council and all of the owners of land within the Scheme Area are unable to agree upon the manner of apportionment thereof the question shall be submitted to arbitration in manner hereinafter provided and at the arbitration hearing each owner may appear personally or by counsel and make submissions to the arbitrator.

42. The amount of Scheme Costs due by each owner is payable within sixty days after the service of the notice referred to in Clause 39 hereof notwithstanding any objection to the apportionment of Scheme Costs but if according to the award of the arbitrator following a submission to arbitration it appears that an owner has paid more than his due proportion of Scheme Costs the Council shall refund the amount of the excess to that owner within fourteen days after the date of the award, but without interest.

Estimate of Scheme Costs.

43. (1) If any of the items of Scheme Costs have not been paid or ascertained at the time of the giving of a notice by the Council they may be estimated by the Council.

(2) An estimate may be revised from time to time.

Arbitration.

44. Any dispute or difference which by the terms of this Scheme may be determined by arbitration may be referred to the arbitration of a single arbitrator in manner provided by the Arbitration Act, 1895, or any statutory modification thereof for the time being in force and if the parties fail to agree upon a single arbitrator he may be nominated by the President for the time being of the Law Society of Western Australia whose nomination is final.

Powers and Authorities of Council.

45. (1) In carrying out the provisions of the Scheme the Council has the following powers and authorities:—

- (a) to enter and inspect any land within the Scheme Area;
- (b) to make arrangements with the owners or occupiers of any land within the Scheme Area;
- (c) to enter into agreements with purchasers or prospective purchasers or prospective occupiers of land within the Scheme Area;
- (d) to enter into agreements with the Crown and any department of the State with reference to the carrying out of any of the objects or works of the Scheme;
- (e) subject to sub-clause (2) if an owner of land does not proceed with the subdivision or development of the land in accordance with the Scheme or by reason of the nature of the land he is unable to subdivide or develop it and his failure to do so will in the opinion of the Council unduly delay the subdivision and development of the Scheme Area, after having given not less than twelve months' written notice of its intention to do so to the owner

to resume or purchase the land or any part or parts thereof and proceed with the subdivision or development of the land in accordance with the provisions of the Scheme as the case may be, and in so doing the Council may enter into agreements with adjoining owners as to the sharing of costs and as to ownership of lots part of which are outside the land resumed by the Council;

- (f) to dispose of any lots to which it becomes entitled whether under paragraph (e) or otherwise upon any terms and conditions it thinks fit and without limiting the generality of the foregoing to sell the lots singly or in groups and on the condition that buildings of a specified character with specified parking or other facilities shall within a limited period be constructed thereon or that the land and buildings be used for a specified purpose;
- (g) to extend the time within which payments are to be made to the Council and agree to the securing of such payments;
- (h) to transfer any land owned by it or acquired by it pursuant to the Scheme as compensation and to enter into agreements relative to the determination and settling of compensation;
- (i) to transfer any land acquired by the Council under Clause 11(2) to the owner of the adjoining land upon any terms and conditions it thinks fit;
- (j) to postpone the implementation of the Scheme for any period the Council thinks fit.

(2) If the Council exercises its powers under paragraph (e) of sub-clause (1) it has all the powers of an owner in the subdivision, development and disposal of the land resumed or purchased but the following provisions apply:—

- (a) if land has been resumed and if the owner has not been paid compensation by reason of the resumption, the Council before selling the land so subdivided and developed shall offer the new lots wholly within the subdivision and the benefit of any agreement with adjoining owners to the original owner upon his paying to the Council all costs and expenses consequent upon the resumption subdivision or development of the said land and upon his releasing the Council from all claims for compensation in respect of such resumption and development;
- (b) the offer shall be made in writing and if not accepted within twenty eight days of the service thereof the Council may proceed with the sale of the subdivided lots;
- (c) all moneys received by it from the sale shall be applied first in payment of all costs and expenses consequent upon the subdivision and secondly in payment of all compensation in respect of the resumption of the said land and the balance (if any) of the moneys may be retained by the Council and the Council shall make good any deficit;
- (d) if the offer mentioned in paragraph (a) hereof is not accepted the Council may retain all or any part of the land but if it does so it is responsible to pay the costs of subdivision of the land and compensation for its resumption as are then unpaid.

46. The Council may exercise the powers conferred by Section 13 of the Act:—

- (a) to purchase any land from any person who may be willing to sell the same; or
- (b) with the consent of the Governor, to take compulsorily, under and subject to the Public Works Act, 1902, (but subject to sub-section (2) of section 13 of the Act), any land comprised in the Scheme and whether situate within or without the boundaries of the district of the Council.

47. One month's written notice is hereby prescribed as the notice to be given pursuant to Section 10 of the Act before the Council exercises the powers conferred by that Section:—

- (a) to remove, pull down or alter any building or other work in the Scheme Area, which has been commenced or continued after the gazettal date and which is such as to contravene the Scheme, and in the erection or carrying out of which any provision of the Scheme has not been complied with;
- (b) to execute any work which it is the duty of any person to execute under the Scheme, in any case where it appears to the Council that delay in the execution of the work would prejudice the efficient operation of the Scheme;

and any expenses incurred by the Council under that section may be recovered from the person in default in a court of competent jurisdiction.

Claims for Compensation.

48. The time within which a person may make a claim for compensation pursuant to section 11 of the Act is six (6) months after the date when notice of the approval of this Scheme is published in the manner prescribed in the regulations made under the Act.

Betterment.

49. Claims made by the Council pursuant to section 11 (2) of the Act shall be made within twelve months of the completion of the work or the section of the work by reason of which the land in which the claim is made is increased in value.

Cessation of Scheme.

50. The Scheme ceases to operate with respect to each stage of development on and upon which the Council certifies in writing that that stage of development has been carried out and completed in accordance with the Scheme.

Adopted by resolution of the Council of the City of Melville at the Ordinary meeting of the Council held on the 23rd day of October, 1979.

J. F. HOWSON, Mayor.
R. H. FARDON, Town Clerk.

Adopted for final approval by resolution of the Council of the City of Melville at the Ordinary meeting of the Council held on the 8th day of July, 1980, and the Seal of the Municipality was pursuant to that resolution hereunto affixed in the presence of:—

J. F. HOWSON, Mayor.
R. H. FARDON, Town Clerk.

Recommended/Submitted for final approval:
DAVID CARR,
Chairman of the Town Planning Board.

Dated this 20th day of January, 1981.

Final approval granted:
JUNE CRAIG,
Minister for Town Planning.
Dated this 20th day of January, 1981.

METROPOLITAN REGION SCHEME.

Notice of Resolution.

File No. 812-2-30-30; Amendment No. 354/27.

NOTICE is hereby given in accordance with the provisions of Clause 27 of the Metropolitan Region Scheme that the Metropolitan Region Planning Authority on 25 March 1981 by resolution of the Authority, transferred from the Urban Deferred Zone to the Urban Zone, that area shown stippled on the plan in the Schedule hereto.

R. E. PETERS,
Acting Secretary,
Metropolitan Region
Planning Authority.

Schedule.

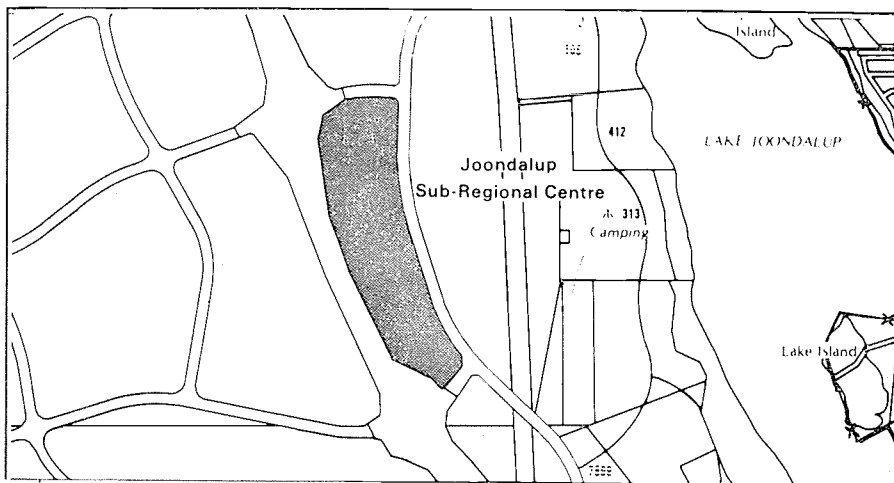

METROPOLITAN REGION SCHEME.

Notice of Resolution.

File No. 812/2/30/29; Amendment No. 353/27.

NOTICE is hereby given in accordance with the provisions of Clause 27 of the Metropolitan Region Scheme that the Metropolitan Region Planning Authority on 25 March 1981, by resolution of the Authority, transferred from the Urban Deferred Zone to the Urban Zone, that area shown stippled on the plan in the Schedule hereto.

R. E. PETERS,
Acting Secretary,
Metropolitan Region
Planning Authority.

Schedule.

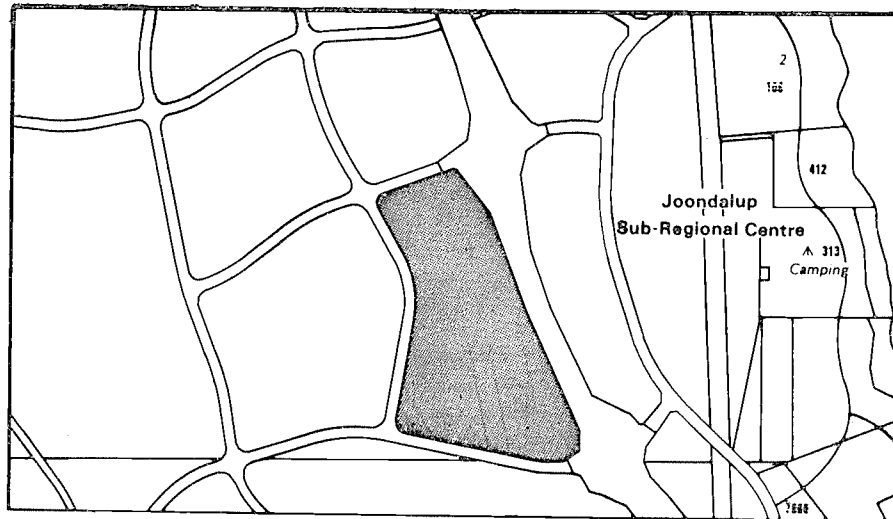
APPENDIX A
REPORT No. H0US/575
 URBAN ZONE
PART OF METROPOLITAN
REGION SCHEME MAP No. 7

PUBLIC WORKS DEPARTMENT.

Tenders, closing at West Perth, at 2.30 p.m. on the dates mentioned hereunder, are invited for the following projects. Tenders are to be addressed to the Minister (either for Works or for Water Resources as indicated on the tender document),

C/- Contract Office
Public Works Department,
Dumas House,
2 Havelock Street,
West Perth. Western Australia 6005,

and are to be endorsed as being a tender for the relevant project.

The highest, lowest, or any tender will not necessarily be accepted.

Contract No.	Project	Closing Date	Tender Documents now available at
22600	Broome Regional Prison New Cell Block and Alterations to Building	7/4/81	P.W.D., West Perth P.W.D., A.D., South Hedland Clerk of Courts, Broome
22603	Carnarvon—Special School—Additions	7/4/81	P.W.D., West Perth P.W.D., A.D., Carnarvon
22605	Pingelly Sewerage Reticulation Area No. 6—Gravity Sewers Schedule of Rates Contract	7/4/81	P.W.D., West Perth
22606	Kununurra P.W.D. Offices Air Conditioning	14/4/81	P.W.D., West Perth P.W.D., A.D., South Hedland P.W.D., A.D., Kununurra
22607	Karnet Rehabilitation Centre—Mechanical Services	7/4/81	P.W.D., West Perth
22608	West Pilbara Water Supply 30 m Radio Mast on Burrup Peninsula	14/4/81	P.W.D., West Perth
22609*	Royal Perth Hospital—North Block Structure—Phase 3	7/4/81	P.W.D., West Perth
22610†	Royal Perth Hospital Shenton Park Annex Hydrotherapy Pool	7/4/81	P.W.D., West Perth
22612	North Albany High School Stage 1—Earthworks	7/4/81	P.W.D., West Perth P.W.D., A.D., Albany
22614	Registration of Tenderers for Queen Elizabeth II Medical Centre Public Health Laboratories J Block Extensions Mechanical Services J36.1	7/4/81	P.W.D., West Perth
22615	Busselton—Lease Portion of Sewerage Treatment Works Site Reserve 35766	7/4/81	P.W.D., West Perth
22616	Fitzroy Crossing Primary School—Air Conditioning Installation Building Work	28/4/81	P.W.D., West Perth P.W.D., A.D. South Hedland Police Station Fitzroy Crossing

PUBLIC WORKS DEPARTMENT—*continued.*

Contract No.	Project	Closing Date	Tender Documents now available at
22617 ...	Albany Regional Prison Mechanical Ventilation Services ...	14/4/81	P.W.D., A.D. Derby P.W.D., West Perth
22618 ...	Fitzroy Crossing Primary School Upgrading Mechanical Services	28/4/81	P.W.D., A.D. Albany P.W.D., A.D. Bunbury P.W.D., West Perth
22619 ...	Albany Technical College Automotive Workshop—Additions— Electrical Installation	7/4/81	P.W.D., A.D. South Hedland P.W.D., A.D., Derby P.W.D., West Perth
22620 ...	Shenton Park-Royal Perth Rehabilitation Hospital—Hydro- therapy Pool—Electrical Installation	14/4/81	P.W.D., A.D. Albany P.W.D., West Perth
22621 ...	Wembley Government Printing Office Factory Ceiling Replace- ment	14/4/81	P.W.D., West Perth
22622 ...	Boulder—Special School—Repairs and Renovations—(External and Internal)	14/4/81	P.W.D., West Perth P.W.D., A.D. Kalgoorlie
22623 ...	Dumbleyung—District High School—Fire Restoration 1981 ...	14/4/81	P.W.D., West Perth P.W.D., A.D. Narrogin
22624 ...	General Cleaning Contract Mineral House, 66 Adelaide Terrace, Perth	14/4/81	P.W.D., West Perth
22625 ...	Geraldton Regional Water Supply—Geraldton-Tarcoola High Level Area—2 250 m ³ Reinforced Concrete Elevated Tank	28/4/81	P.W.D., West Perth P.W.D., Eng. Division, Ger- aldton
22626 ...	Karratha Depot—Dismantling, Transportation from Pt. Sam- son and re-erection of Storage Shed at Karratha Depot	28/4/81	P.W.D., West Perth P.W.D., Engineering Division Karratha
22627 ...	Port Hedland Hospital Alterations and Additions to X-Ray Department	28/4/81	P.W.D., West Perth P.W.D., A.D. Pt. Hedland P.W.D., A.D., Geraldton
22628 ...	Kojonup District High School—Upgrade	28/4/81	P.W.D., West Perth P.W.D., A.D., Albany Police Station, Kojonup
22629 ...	Balga Senior High School—Gymnasium Erection	14/4/81	P.W.D., West Perth
22630 ...	Balga Senior High School—Gymnasium Multi-Purpose Floor- ing to Gymnasium (N.S.C.)	14/4/81	P.W.D., West Perth
22631 ...	Canning Vale—Registration of Tenderers for Metropolitan Prison Complex Supply and Installation of Security Doors	14/4/81	P.W.D., West Perth
22632 ...	Sale of Portion North Fremantle Town Lot 18 being Lot 7 on Plan 1297 Certificate of Title 1050 Folio 318 Burns Street	28/4/81	P.W.D., West Perth
22633 ...	Leonora Town Water Supply—Construction of 225 m ³ Re- inforced Concrete Circular Roofed Tank	28/4/81	P.W.D., West Perth
22634 ...	Millars Well—Primary School—Storm Shutters (N.S.C.) ...	28/4/81	P.W.D., West Perth P.W.D., A.D., Karratha
22635 ...	Kalgoorlie Regional Hospital—Stage II Redevelopment—Steam Main Installation	28/4/81	P.W.D., West Perth P.W.D., A.D., Kalgoorlie
22596 ...	Boulder Primary School Alterations and Additions—Recall ...	28/4/81	P.W.D., West Perth P.W.D., A.D., Kalgoorlie P.W.D., A.D. Northam
22636 ...	R.P.H.—Shenton Park Annex Hydrotherapy Pool—Mechanical Services	28/4/81	P.W.D., West Perth
22637 ...	Newdegate Research Station New 25 kVA Diesel Alternator Set	28/4/81	P.W.D., West Perth P.W.D., A.D., Narrogin
22638 ...	Woodman's Point Camp (Munster)—Department for Youth, Sport and Recreation—Kitchen Dining Additions 1981	28/4/81	P.W.D., West Perth
22639 ...	Katanning Hospital—Remodelling and Repairs and Renovations to Permanent Care Unit Recall	28/4/81	P.W.D., West Perth P.W.D., A.D., Bunbury P.W.D., A.D., Albany Clerk of Courts Katanning
ADQ2613	Dalwallinu District High School Additions to Administration Offices Supply and Lay Carpet	14/4/81	P.W.D., A.D., Furniture Office, 2nd Floor Dumas House, 2 Havelock Street, West Perth 6005 P.W.D., A.D., 26 Gordon Street, Northam 6401
ADQ2614	Busselton Senior High School Community Recreation Centre Supply and Lay Carpet	14/4/81	P.W.D., A.D., Furniture Office, Dumas House, Room 223, 2 Havelock Street, West Perth 6005 P.W.D., A.D., 11 Stirling Street, Bunbury 6230
ADQ2615	Balga Senior High School Library Resource Centre Supply and Lay Carpet	14/4/81	P.W.D., A.D., Furniture Office, Dumas House, Room 223 2 Havelock Street, West Perth 6005
ADQ2616	Balcatta Senior High School Poincare Street Supply and Lay Carpet	28/4/81	P.W.D., A.D., Furniture Office, Dumas House, 2 Havelock Street West Perth 6005
ADQ2617	Hainsworth Primary School Harford Way, Girrawheen Supply and Lay Carpet	28/4/81	P.W.D., A.D., Furniture Office, Dumas House Room 223 2 Havelock Street West Perth 6005

* Deposit for documents—\$100.

† Deposit for documents—\$75.

PUBLIC WORKS DEPARTMENT—*continued.*

ACCEPTANCE OF TENDERS

Contract No.	Project	Contractor	Amount
			\$
22570	Bunbury Dental Clinic—Mechanical Services	Sterling Refrigeration and Air Conditioning	34 991
22588	Albany Technical College Automotive Workshop Additions	Wauters Enterprises	181 200
22580	Exmouth District High School—Air Conditioning	Kelvin Industries Ltd	80 223
22571	Hampton Senior High School Community Recreation Centre—Electrical Installation	W. & G. Janissen	37 518
22550	Perth—District Court Building—PABX Installation	Ericsson Communications	148 888

K. T. CADEE,
Acting Under Secretary for Works.

M.R.D. 42/55-F

Main Roads Act 1930–1977; Public Works Act 1902–1974

NOTICE OF INTENTION TO TAKE OR RESUME LAND

THE Minister for Works hereby gives notice, in accordance with the provisions of Section 17(2) of the Public Works Act 1902–1974, that it is intended to take or resume under Section 17(1) of that Act the pieces or parcels of land described in the Schedule hereto and being all in the Augusta District, for the purpose of the following public works namely, widening the Bunbury-Augusta Road, and that the said pieces or parcels of land are marked off on OP 14905 which may be inspected at the office of the Commissioner of Main Roads, Waterloo Crescent, East Perth.

SCHEDULE

No.	Owner or Reputed Owner	Occupier or Reputed Occupier	Description	Area (approx.)
1.	Terrence John Adams, Rokrol Pty Ltd and Sirene Investments Pty Ltd	T. J. Adams, Rokrol Pty Ltd and Sirene Investments Pty Ltd	Portion of Sussex Location 1343 and being Lot 6 the subject of Diagram 56061 (Certificate of Title Volume 1546 Folio 772)	433 m ²
2.	Raymond John Ellis and Donald Anthony Ellis	Hon. Minister for Works (Purchaser vide Caveat B914741)	Portion of Sussex Location 934 (Certificate of Title Volume 1397 Folio 423)	6 991 m ²
3.	Victor Harrison Hill	Hon. Minister for Works (Purchaser vide Caveat B715641)	Portion of Sussex Location 1343 and being Lot 4 on Diagram 41637 (Certificate of Title Volume 1324 Folio 885)	722 m ²
4.	Gertrude Jane Holland	G. J. Holland	Portion of Sussex Location 1343 and being part of Lot 2 on Diagram 37629 (Certificate of Title Volume 1546 Folio 773)	7 m ²

This notice supersedes Items 1, 2 and 4 of the Notice of Intention to Resume published on Page 3646 of the *Government Gazette* dated October 24, 1980.

Dated this 1st day of April, 1981.

D. R. WARNER,
Secretary, Main Roads.

M.R.D. 42/165-A

Main Roads Act 1930–1977; Public Works Act 1902–1974

NOTICE OF INTENTION TO TAKE OR RESUME LAND

THE Minister for Works hereby gives notice, in accordance with the provisions of Section 17(2) of the Public Works Act 1902–1974, that it is intended to take or resume under Section 17(1) of that Act the pieces or parcels of land described in the Schedule hereto and being all in the Carnamah and Coorow District, for the purpose of the following public works namely, Brand Highway Controlled Access Road (realignment south of Eneabba Townsite) and that the said pieces or parcels of land are marked off on Plan M.R.D. W.A. 7321–45 which may be inspected at the office of the Commissioner of Main Roads, Waterloo Crescent, East Perth.

SCHEDULE

No.	Owner or Reputed Owner	Occupier or Reputed Occupier	Description	Area (approx.)
1.	Minoo Khodadad Fozdar & Marjorie Lov Fozdar	M. K. & M. L. Fozdar	Portion of Crown Lease 269/1970 in the District of Victoria	36·956 ha

Dated this 3rd day of April, 1981.

D. R. WARNER,
Secretary, Main Roads.

METROPOLITAN WATER SUPPLY, SEWERAGE AND DRAINAGE BOARD.

Metropolitan Sewerage.

Notice of Intention.

M.W.B. 676216/80; (S04.090).

NOTICE is hereby given, pursuant to section 20 of the Metropolitan Water Supply, Sewerage, and Drainage Act 1909-1980 of the intention of the Board to undertake the construction of the following works, namely:—

City of Stirling.

Sewerage Reticulation Area 7A Balcatta.

Description and Locality of Proposed Works:

The construction of:—

- (a) A brick and concrete pumping station and a reinforced concrete well together with a three hundred millimetre diameter rising main and all other apparatus connected therewith.
(b) Three hundred and five millimetre, two hundred and thirty millimetre, one hundred and fifty millimetre and one hundred millimetre diameter reticulation pipe sewers together with manholes and all other apparatus connected therewith.

The above works and localities are shown on plan M.W.B. 17545, a copy of which is published herewith.

The Purpose for which the Proposed Works are to be Constructed:

For the disposal of wastewater and to connect premises to the main sewer.

The Times and Place at which the Plan may be Inspected:

At the office of the Board, Metropolitan Water Centre, 629 Newcastle Street, Leederville, for one month on and after the 3rd day of April, 1981, between the hours of 9.30 a.m. and 3.30 p.m.

H. J. GLOVER, Commissioner.

NOTE:

Sections 19, 21 and 22 of the Metropolitan Water Supply, Sewerage, and Drainage Act 1909-1980 provide that any local authority or person interested may lodge a written objection with the Board against the construction or provision of the proposed works, within one month after the date of publication of the above notice.

After the period for receipt of objections has expired, and the objections, if any, have been met by amendment of the proposal or are, in the general public interest, not sufficient to cause the proposals to be amended, the Governor may make an order, a notice of which is published in the Government Gazette, authorising the Board to carry out the construction or provision of the proposed works.

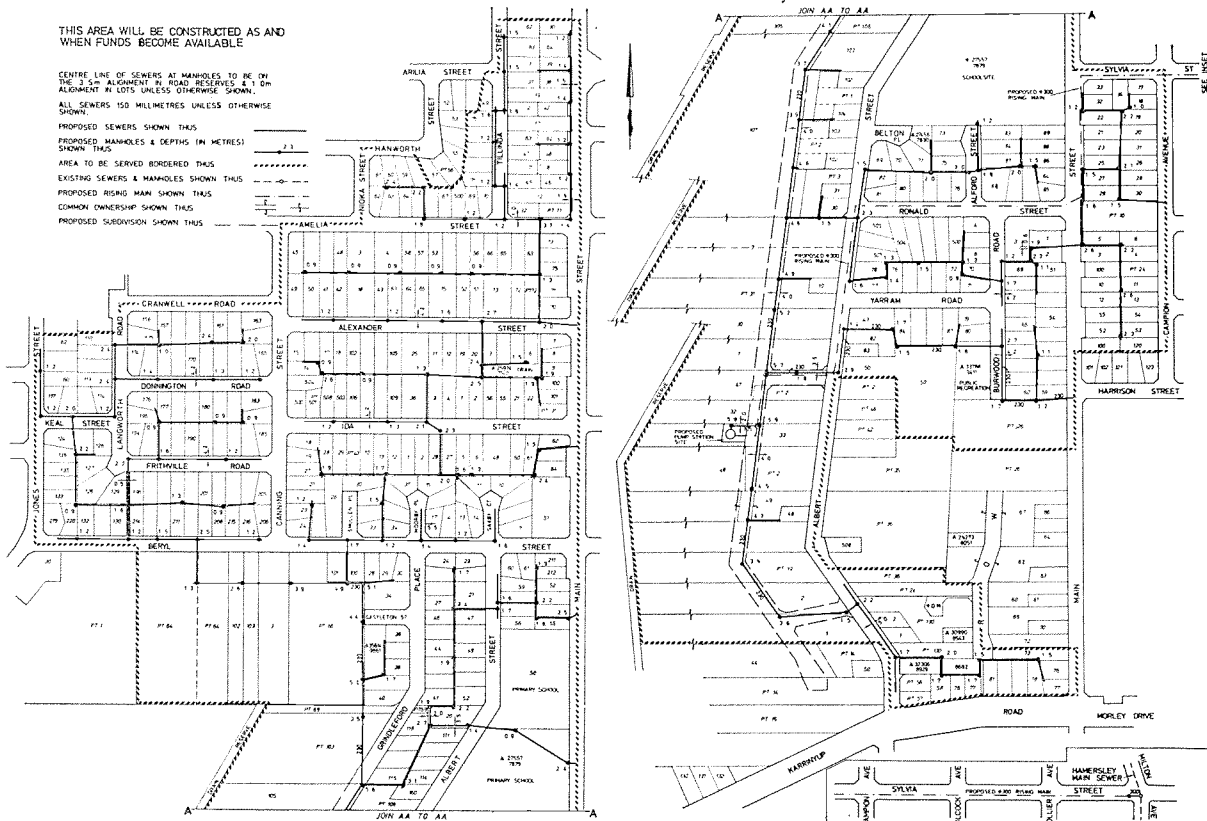

SHIRE OF BAYSWATER.

STATEMENT OF RECEIPTS AND PAYMENTS FOR THE YEAR ENDED 30 JUNE 1980.

Receipts.		\$
Rates	2 412 033.44	
Licences	36 103.97	
Government Grants and Recoups	856 625.96	
Income from Property	212 233.01	
Sanitation Charges	446 936.94	
Town Planning	34 812.00	
Fines and Penalties	5 103.30	
Contributions to Works	145 703.47	
All Other Revenue	135 877.59	
All Other Receipts	56 136.40	
Suspense Accounts	158 568.56	
Bank Transfers	397 214.25	
	<u>\$4 897 348.89</u>	

Payments.		\$
Administration—		
Staff Section	331 549.43	
Membership Section	28 254.37	
Debt Service	802 623.93	
Public Works and Services—		
Streets, Roads and Bridges	984 098.69	
Parks and Reserves Development	104 471.41	
Parks and Reserves Maintenance	660 641.37	
Building Construction and Equipment	64 863.07	
Building Maintenance	96 003.95	
Other Public Works and Services	257 734.22	
Town Planning	118 294.90	
Health Services	470 468.96	
Library	89 933.32	
Community Recreation	18 515.94	
Civil Emergency Service	1 665.90	
Traffic Control	26 737.90	
Building Control	67 846.47	
Public Works Overheads	97 541.06	
Furniture and Equipment	8 639.16	
Plant, Machinery and Tools	101 927.32	
Plant Operation Costs	25 946.01	
Materials	31 511.62	
Donations and Grants	106 051.79	
Suspense Accounts	208 427.54	
Differential Rate Area	14 021.00	
Transfer to Reserves	78 573.01	
Bank Transfers	397 214.25	
	<u>\$5 193 556.59</u>	

SUMMARY.

Balance at 1/7/79	Cr.	194 846.51
Receipts to 30/6/80		4 897 348.89
		<u>5 092 195.40</u>
Less Payments to 30/6/80		5 193 556.59
	Dr.	<u>\$101 361.19</u>

BALANCE SHEET AS AT 30 JUNE 1980.

Assets.		\$
Current Assets	118 735.37	
Non-current Assets	1 011 737.94	
Deferred Assets	1 585 833.15	
Fixed Assets	3 562 912.61	
	<u>\$6 279 219.07</u>	
Liabilities.		\$
Current Liabilities	139 924.81	
Non-current Liabilities	527 825.88	
Deferred Liabilities	4 998 126.31	
	<u>\$5 665 877.00</u>	

SUMMARY.

Total Assets	6 279 219.07
Total Liabilities	5 665 877.00
Municipal Accumulation Surplus	<u>\$613 342.07</u>

We hereby certify that the particulars and figures as shown are correct.

N. E. DAVIS,
President.

K. B. LANG,
Shire Clerk.

I have examined the books of account and applied audit checks to the financial transactions of the Shire of Bayswater for the year ended 30 June 1980.

The accompanying financial statements are, in my opinion, properly drawn up in accordance with the Local Government Act Accounting Directions so as to give a true and fair view of the state of affairs of the Shire of Bayswater at 30 June 1980, subject to the qualifications contained in my separate report.

E. B. PEGG,
Government Inspector of Municipalities.

SHIRE OF MURRAY.
STATEMENT OF RECEIPTS AND PAYMENTS FOR THE YEAR ENDED 30 JUNE 1980.

Receipts.		\$
Rates	401 735.09	
Licences	10 502.64	
Government Grants	469 415.59	
Contribution to Works and Private Works	130 038.54	
Income from Property	26 621.23	
Sanitation	40 054.21	
Town Planning	1 260.00	
Cemetery	1 021.00	
Library Services	15.36	
Other Services	1 319.39	
Fines and Penalties	5 105.50	
Sale of Assets	40 454.50	
Other Receipts	136 048.73	
Refunds and Transfers (Net)	4 336.62	
	<u>\$1 267 928.40</u>	

Payments.		\$
Administration:		
Staff	94 962.18	
Members	9 613.47	
Debt Service	200 236.51	
Public Works and Services:		
Road Construction	292 104.81	
Road Maintenance	129 489.90	
Reserves Construction	31 246.91	
Reserves Maintenance	56 420.07	
Building Construction and Fixed Equipment	4 606.00	
Building Maintenance	34 015.69	
Equipment Purchases	8 670.51	
Plant Purchases	40 327.13	
Sanitation Service	65 728.17	
Health Service	20 375.91	
Building Service	20 492.08	
Town Planning Service	16 192.82	
Cemetery	2 104.93	
Library Service	9 410.99	
Bush Fire Control	10 506.26	
Other Public Services	15 286.69	
Pay Roll	—	
Public Works Overhead	—	
Plant Operation Cost	—	
Materials	9 624.37	
Donations and Grants	4 532.37	
Transfers to Reserve Funds	50 000.00	
All Other Expenditure	17 736.87	
Refunds and Transfers	—	
	<u>\$1 124 435.90</u>	

SUMMARY.

Credit Bank Balance 1/7/1979	Cr.	20 658.12
Receipts as per Statement		1 267 928.40
		<u>1 288 586.52</u>
Payments as per Statement		1 124 435.90
Credit Balance 30/6/80	Cr.	<u>\$164 150.62</u>

BALANCE SHEET AS AT 30 JUNE 1980.

Assets.		\$
Current Assets:		
Cash at Bank	164 150.62	
Petty Cash	150.00	
Sundry Debtors	91 124.82	
Stock on Hand	12 244.92	
Non-current Assets	167 171.70	
Deferred Assets	868 931.35	
Contra Reserve Accounts	105 196.65	
Fixed Assets	1 292 251.89	
	<u>\$2 701 221.95</u>	
Liabilities		\$
Current Liabilities:		
Sundry Creditors	2 157.06	
Accrued Interest on Loans	25 660.71	
Non-current Liabilities:		
Trust Funds	46 582.72	
Long Service Leave Reserve	14 074.48	
Plant Replacement Reserve	80 134.35	
General Reserve	10 717.54	
Deferred Liabilities:		
Loan Liability	1 404 939.56	
	<u>\$1 584 266.42</u>	

We hereby certify that the figures and particulars in accordance with statements attached are correct.

A. B. GILES,
President.

B. M. BAKER,
Shire Clerk.

Dated 28 January 1981.

I have examined the books of account and applied audit test checks to the financial transactions of the Shire of Murray for the financial year ended 30 June 1979. The accompanying financial statements are in my opinion properly drawn up to give a true and fair view of the state of affairs of the Shire of Murray at 30 June 1980, subject to qualifications/or observations contained in my report.

M. J. BREMAN,
(Auditor—Audit Department),
Auditor General's Department.

CITY OF COCKBURN.

IT is hereby notified for public information that Mr. Edwin Roy O'Meara has been appointed Building Inspector for the City of Cockburn.

A. J. ARMAREGO,
Town Clerk.

SHIRE OF GREENOUGH.

Beach Inspector.

IT is hereby notified for public information that Mr. George Alfred Hills has been appointed as an honorary Beach Inspector under Council's Safety, Decency, Convenience and Comfort of Persons in Respect to Bathing By-laws.

R. G. BONE,
Shire Clerk.

DOG ACT 1976-1977.

Shire of Meekatharra.

IT is hereby notified for public information that the following have been appointed as Authorised Officers under the provisions of the Dog Act 1976-1977.

Leslie Peter Strugnell.
Raymond Noel Bain.
Enid Anne Nichols.
Sharon Kaye Adamini.

L. P. STRUGNELL,
Shire Clerk.

DOG ACT 1976-1977.

Shire of Merredin.

IT is hereby notified for public information that John Herbert Beaton has been appointed as an authorised officer under the provisions of the Dog Act 1976-1977.

All previous appointments are hereby cancelled.

R. LITTLE,
Shire Clerk.

SHIRE OF SERPENTINE-JARRAHDAL.

Honorary Litter Inspectors.

IT is hereby notified for public information that the following appointments of Honorary Litter Inspectors are made under section 665A of the Local Government Act 1960-1980 as from 16 March 1981 for the Shire of Serpentine-Jarrahdale:—

Mr. R. Blake.
Mr. R. Emiliani.
Mr. P. Jackson.

By Order of the Council,

L. E. MANN,
Shire Clerk.

Form No. 30

LOCAL GOVERNMENT ACT 1960-1976

SHIRE OF WANNEROO

SALE OF LAND FOR RATES

NOTICE is hereby given that default in the payment of rates for a period of not less than three years having occurred the Shire of Wanneroo, acting under the powers conferred by Subsection C of Division 6 of Part XXV of the Local Government Act 1960-1976 as amended, will offer for sale, by public auction, at the Wanneroo Civic Centre, Wanneroo Road, Wanneroo on the second day of May 1981 at 10.00 a.m. the pieces of land specified in the schedule hereto.

N. S. BENNETTS.

Schedule

Description of Land and Lot number	Title Reference	Area	Street/ Suburb	Description of improvements if any	Name of Registered Proprietor	Name of any other persons appearing to have an interest in the land	Rates Out-standing	Other Charges due on Land
Lot 19, Swan Loc. 1370	Volume 1379 Folio 642	810 m ²	Valkyrie Place Two Rocks	David Boyd Somerville	\$ 742.90	\$ 45.25
Lot 28, Swan Loc. 1370	Volume 1379 Folio 651	810 m ²	Galatea Grove Two Rocks	John and Janece Lillian Hay	Commercial and General Acceptance Limited	672.50	48.22
Lot 266, Swan Loc. 1370	Volume 620 Folio 56A	1 184 m ²	Brazier Road, Yanchep	William Charles Maizey	Commission of State Taxation Commonwealth Trading Bank of Australia, Dunlop Tyre Service, G.I.C. Broadlands Limited. D.M.U. Pty Ltd and Charles Ian Timothy Clifford	768.46	60.10

LOCAL GOVERNMENT ACT 1960-1980.

City of Subiaco.

Notice of Intention to Borrow.

Proposed Loan (No. 84) of \$150 000.

PURSUANT to section 610 of the Local Government Act 1960-1980, the City of Subiaco hereby gives notice that it proposes to borrow money by the sale of debentures on the following terms and for the following purpose: \$150 000 for a period of 7 years repayable at the office of the City of Subiaco, Rokeby Road, Subiaco, by fourteen (14) equal half-yearly instalments of principal and interest. Purpose: Development of Endowment Lands.

Plans, specifications and estimates of cost and statements as required by section 609 of the Act are available for inspection at the office of the Council during normal office hours for a period of 35 days after the publication of this notice.

Dated this 26th day of March, 1981.

R. V. DIGGINS,
Mayor.J. F. R. McGEOUGH,
Town Clerk.**CORRIGENDUM.**

City of Belmont.

THE period for repayment appearing in the loan advertisement as described below should have read ten years.

Loan No. 126, \$20 000, *Government Gazette* 12/9/1980, page 3239.

Loan No. 127, \$100 000, *Government Gazette* 12/12/1980, page 4249.

F. W. RAE,
Mayor.G. SWINTON-BRAY,
Town Clerk.**CORRIGENDUM.**

LOCAL GOVERNMENT ACT 1960-1980.

Town of Kwinana.

Notice of Intention to Borrow.

Proposed Loan (No. 81) of \$40 000.

THE notice published in *Government Gazette* (No. 89) dated 31 December 1980, on page 4443 is amended as follows:—

Delete: "The Purpose: To complete roadworks programme for 1980/81."

Substitute: "The Purpose: Purchase of Plant".

F. G. J. BAKER,
Mayor.L. G. BAKER,
Town Clerk.**CORRIGENDUM.**

LOCAL GOVERNMENT ACT 1960-1980.

Town of Kwinana.

Notice of Intention to Borrow.

Proposed Loan (No. 80) of \$40 000.

THE notice published in *Government Gazette* (No. 89) dated 31 December 1980, on page 4443 is amended as follows:—

Delete: "The Purpose: Purchase of Plant".

Substitute: "The Purpose: To complete roadworks programme for 1980/81".

F. G. J. BAKER,
Mayor.L. G. BAKER,
Town Clerk.

LOCAL GOVERNMENT ACT 1960-1980.

Shire of Carnarvon.

Notice of Intention to Borrow.

Proposed Loan (No. 121) of \$64 600.

PURSUANT to section 610 of the Local Government Act 1960-1980, the Shire of Carnarvon hereby gives notice of its intention to borrow money by the sale of debentures on the following terms and for the following purpose: \$64 600 for a period of ten (10) years with a notional term of twenty (20) years, repayable at the office of the Council, Carnarvon, by half-yearly instalments of interest and principal. Purpose: Part cost of purchase of three (3) dwellings for the State Energy Commission.

Plans, specifications and estimates as required by section 609 of the Act are available at the office of the Council during office hours for a period of thirty-five (35) days after publication of this notice.

Dated this 23rd day of March, 1981.

R. G. FIDOCK,
President.A. J. TAYLOR,
Shire Clerk.

LOCAL GOVERNMENT ACT 1960-1980.

Shire of Cunderdin.

Notice of Intention to Borrow.

Proposed Loan (No. 61) of \$13 000.

PURSUANT to section 610 of the Local Government Act 1960-1980 the Cunderdin Shire Council hereby gives notice that it proposes to borrow money, by the sale of debentures on the following terms and for the following purpose: \$13 000 for ten (10) years at a rate of interest not exceeding 15.0% per annum repayable at the Bank of New South Wales Savings Bank Ltd., Cunderdin by twenty (20) equal half-yearly instalments of principal and interest. Purpose: Purchase of land and residence, being Cunderdin Town Lot 376.

Plans, specifications, estimates and statements required by section 609, are open for the inspection of ratepayers at the office of the Council during normal business hours, for a period of thirty-five (35) days after the publication of this notice.

L. A. REYNOLDS,
President.N. J. ALCOCK,
Shire Clerk.

SHIRE OF DANDARAGAN.

Closure of Road.

NOTICE is hereby given pursuant to section 334 of the Local Government Act 1960-1980 that the Council has under consideration the temporary closure of portion of Cantabilling Road, (road number 4280) from Brand Highway to the northeastern corner of location 3738.

The period of this temporary closure to be ten years initially.

Objections to the proposed closure should be lodged with the Shire Clerk within thirty-five (35) days of this notice.

Dated this 23rd day of March, 1981.

M. T. WAYMAN,
Shire Clerk.

LOCAL GOVERNMENT ACT 1960-1980.

Shire of Dundas.

Notice of Intention to Borrow.

Proposed Loan (No. 42) of \$17 000.

PURSUANT to section 610 of the Local Government Act 1960-1980 the Council of the Shire of Dundas hereby gives notice of its intention to borrow money by the sale of debentures on the following terms and for the following purpose: \$17 000 for a period of 20 years repayable by 40 equal half-yearly instalments of principal and interest. Purpose: Extensions to the Salmon Gums Golf Club House.

Plans, specifications and estimates as required by section 609 of the Act are available for inspection at the offices of the Council during normal office hours for a period of thirty five days after publication of this notice.

Repayments of instalments of Principal and Interest in respect of the loan will be met by the Salmon Gums Golf Club and will not affect Local Authority rates.

Dated this 23rd day of March, 1981.

A. I. GUEST,
President.

L. GIBLETT,
Shire Clerk.

LOCAL GOVERNMENT ACT 1960-1980.

Shire of Kellerberrin.

Notice of Intention to Borrow.

Proposed Loan (No. 91) of \$15 000.

PURSUANT to section 610 of the Local Government Act 1960-1980 the Shire of Kellerberrin hereby gives notice that it proposes to borrow money by sale of debenture on the following terms and for the following purposes: \$15 000 for a period of ten (10) years repayable at the office of the Shire of Kellerberrin by twenty (20) equal half-yearly instalments of principal and interest. Purpose: Purchase of Residence on Lot 127 Forrest Street, Kellerberrin.

Note: Annual Repayments of Principal and interest will be met in full by T. A. Andrews and thus no charge upon Council revenue. Details and estimates of cost as required by section 609 can be obtained from Council Office for 35 day after publication of this notice.

P. J. LEAKE,
President.

B. R. THOMPSON,
Shire Clerk.

LOCAL GOVERNMENT ACT 1960-1980.

Shire of Mullewa.

Notice of Intention to Borrow.

Proposed Loan (No. 74) of \$40 000.

PURSUANT to sections 609 and 610 of the Local Government Act 1960-1980, the Council of the Municipality of the Shire of Mullewa hereby gives notice of its proposal to borrow money by the sale of a debenture on the following terms and for the following purpose: \$40 000 for a period of 5 years to be repayable at the Bank of New South Wales, Mullewa, by 10 instalments of principal and interest. Purpose: Construction of caravan park, Mullewa Lot AA23 being Part 1.

Plans and specifications together with estimates of cost are open for inspection by ratepayers at the Shire Council office during normal office hours for a period of 35 days after publication of this notice.

Dated this 19th day of March, 1981.

D. J. BREMKLEY,
President.

T. J. HARKEN,
Shire Clerk.

LOCAL GOVERNMENT ACT 1960-1980.

Shire of Pingelly.

Notice of Intention to Borrow.

Proposed Loan (No. 87) of \$8 700.

PURSUANT to section 610 of the Local Government Act 1960-1980, the Council of the Shire of Pingelly gives notice that it proposes to borrow money by the sale of debentures, on the following terms and conditions and for the following purpose: \$8 700 over two (2) years, repayable at the office of the Shire of Pingelly in four equal half-yearly instalments of principal and interest. Purpose: Replacement of vehicles—sedan and one ton utility.

Plans, specifications and estimates of cost, as required under section 609 of the Act, are available for inspection at the office of the Council during normal office hours for a period of thirty-five (35) days from the publication of this notice.

J. S. WATTS,
President.

A. R. BILICZKA,
Shire Clerk.

LOCAL GOVERNMENT ACT 1960-1980.

Shire of Pingelly.

Notice of Intention to Borrow.

Proposed Loan (No. 86) of \$15 000.

PURSUANT to section 610 of the Local Government Act 1960-1980, the Council of the Shire of Pingelly gives notice that it proposes to borrow money by the sale of debentures, on the following terms and conditions and for the following purpose: \$15 000 over ten (10) years, repayable at the Office of the Shire of Pingelly in twenty equal half yearly instalments. Purpose: Road construction—(Contribution $\frac{1}{3}$ cost of resealing portion of Pingelly-Yealering Road in conjunction with M.R.D.).

Plans, specifications and estimates of cost, as required by section 609 of the Act, are available for inspection at the Office of the Council during normal office hours for a period of thirty five (35) days from the publication of this notice.

J. S. WATTS,
President.

A. R. BILICZKA,
Shire Clerk.

LOCAL GOVERNMENT ACT 1960-1980.

Shire of Quairading.

Notice of Intention to Borrow.

Proposed Loan (No. 91) of \$17 000.

PURSUANT to section 610 of the Local Government Act 1960-1980, the Council of the Shire of Quairading hereby gives notice that it proposes to borrow money by sale of Debentures on the following terms and for the following purpose. Terms: \$17 000 for a period of ten years repayable at the office of the Bank of New South Wales by twenty equal half-yearly instalments of Principal and Interest. Purpose: Acquisition of Natural Wood Sculpture from the Estate of the late Ian J. Willis.

A schedule of items and costs as required by the Act is available for inspection at the Council office. Objections to the proposed loan must be lodged within 35 days of this notice.

A. C. KELLY,
President.

T. L. WHITE,
Shire Clerk.

LOCAL GOVERNMENT ACT 1960-1980.

Shire of Rockingham.

Notice of Intention to Borrow.

Proposed Loans (No. 141) of \$150 000, (No. 142) of \$204 000, (No. 143) of \$264 000.

PURSUANT to section 610 of the Local Government Act 1960-1980, the Council of the Shire of Rockingham hereby gives notice that it proposes to borrow money by the sale of debentures on the following terms and for the following purposes:—

Loan No. 141—\$150 000: One Hundred and Fifty Thousand Dollars for a period of five years, repayable to the National Bank of Australasia, Rockingham in ten equal half-yearly instalments of principal and interest. Purpose: Purchase of plant.

Loan No. 142—\$204 000: Two Hundred and Four Thousand Dollars for a period of fifteen years, repayable to the National Bank of Australasia, Rockingham in thirty equal half-yearly instalments of principal and interest. Purpose: Roadworks.

Loan No. 143—\$264 000: Two Hundred and Sixty-Four Thousand Dollars for a period of fifteen years, repayable to the National Bank of Australasia, Rockingham in thirty equal half-yearly instalments of principal and interest. Purpose: Development of Reserves.

Plans and specifications and estimates required by section 609 are open for inspection of ratepayers at the offices of the Council during business hours, for thirty-five days from the publication of this notice.

W. D. A. MAYS,
President.

D. J. CUTHBERTSON,
Shire Clerk.

LOCAL GOVERNMENT ACT 1960-1980.

Shire of Swan.

Notice of Intention to Borrow.

Proposed Loan (No. 63) of \$61 000.

PURSUANT to section 610 of the Local Government Act 1960-1980, the Shire of Swan hereby gives notice that it proposes to borrow money by the sale of debentures on the following terms and for the following purposes: Sixty-one thousand dollars for a period of five years repayable at the Office of the Council, Middle Swan, by ten half-yearly instalments of principal and interest. Purpose: Purchase of plant.

Plans, specifications and estimates of costs as required by section 609 of the Act are open for inspection at the Office of the Council at Middle Swan during office hours for 35 days after publication of the notice.

Dated this 27th day of March, 1981.

C. M. GREGORINI,
President.

R. S. BLIGHT,
Acting Shire Clerk.

LOCAL GOVERNMENT ACT 1960-1980.

Shire of Wyndham-East Kimberley.

Notice of Intention to Borrow.

Proposed Loan (No. 66) of \$50 000.

PURSUANT to section 610 of the Local Government Act 1960-1980, the Wyndham-East Kimberley Shire Council hereby gives notice that it proposes to borrow money by the sale of a debenture or debentures on the following term and for the following purpose: \$50 000 for five (5) years at the ruling interest rate, repayable at the office of the Council in Wyndham, by ten (10) equal half-yearly instalments of principal and interest. Purpose: Wyndham Electricity Undertaking—Generating Plant, Equipment, Buildings, Mains Extension, Land, Housing and Minor Capital Works.

Plans, specification and estimates as required by section 609 of the Act are available for inspection at the office of the Council during normal business hours for a period of thirty-five (35) days after publication of this notice.

Note: All repayments on this loan will be met in full by the State Energy Commission of Western Australia. This notice supersedes previous notice published in the *Government Gazette* on 29 August 1980.

Dated this 24th day of March, 1981.

P. B. REID,
President.

M. N. BROWN,
Shire Clerk.

LOCAL GOVERNMENT ACT 1960-1980.

Shire of Wyndham-East Kimberley.

Notice of Intention to Borrow.

Proposed Loan (No. 71) of \$50 000.

PURSUANT to section 610 of the Local Government Act 1960-1980, the Wyndham-East Kimberley Shire Council hereby gives notice that it proposes to borrow money by the sale of a debenture or debentures on the following term and for the following purpose: \$50 000 for five (5) years at the ruling interest rate, repayable at the office of the Council in Wyndham, by ten (10) equal half-yearly instalments of principal and interest. Purpose: Wyndham Electricity Undertaking—Generating Plant, Equipment, Buildings, Mains Extension, Land, Housing and Minor Capital Works.

Plans, specification and estimates as required by section 609 of the Act are available for inspection at the office of the Council during normal business hours for a period of thirty-five (35) days after publication of this notice.

Note: All repayments on this loan will be met in full by the State Energy Commission of Western Australia.

Dated this 24th day of March, 1981.

P. B. REID,
President.

M. N. BROWN,
Shire Clerk.

LOCAL GOVERNMENT ACT 1960-1980.

City of Cockburn.

Closure of Private Street.

Department of Local Government,
Perth, 18 February 1981.

LG: CC-4-12.

It is hereby notified for public information that His Excellency the Governor has approved under the provisions of section 297A of the Local Government Act 1960-1980, the resolution passed by the City of Cockburn that the following private streets be closed:—

1. Portion of Cockburn Sound Location 550 being part of the land the subject of Plan 13021 and being part of the land within Certificate of Title Volume 1547 Folio 801 and the land contained therein be allocated to the adjoining lots 379 and 384 Fluellen Way.
2. Portion of Cockburn Sound Location 550 being part of the land the subject of Plan 13066 and being part of the land within Certificate of Title Volume 1554 Folio 701 and the land contained therein be allocated to the adjoining lot 192 Quickly Crescent.
3. Portion of Cockburn Sound Location 550 being part of the land the subject of Plan 13000 and Diagrams 57772 and 58137 and being part of the land within Certificate of Title Volume 1410 Folio 777 and the land contained therein be allocated to the adjoining lot 432 Stanyford Place.

4. Portion of Cockburn Sound Location 550 being part of the land the subject of Plan 13066 and being part of the land within Certificate of Title Volume 1554 Folio 701 and the land contained therein be allocated to the adjoining lot 399 Quickly Crescent.
5. Portion of Cockburn Sound Location 550 being part of the land the subject of Plan 12884 and being part of the land within Certificate of Title Volume 1500 Folio 27 and the land contained therein be allocated to the adjoining lot 177 Ely Street.
6. Portion of Cockburn Sound Location 550 being part of the land the subject of Diagram 57126 and being part of the land within Certificate of Title Volume 1500 Folio 27 and the land contained therein be allocated to the adjoining Lot 174 Southwell Crescent.
7. Portion of Cockburn Sound Location 550 being part of the land the subject of Plan 13066 and being part of the land within Certificate of Title Volume 1554 Folio 701 and the land contained therein allocated to the adjoining lots 400-404 Honeysett Court.
8. Portion of Cockburn Sound Location 550 being part of the land the subject of Plan 11049 and being part of the land within Certificate of Title Volume 1410 Folio 777 and the land contained therein be allocated to the adjoining lot 64 Helena Place.
9. Portion of Cockburn Sound Location 550 being part of the land the subject of Plan 13021 and being part of the land within Certificate of Title Volume 1547 Folio 801 and the land contained therein be allocated to the adjoining lot 216 Quickly Crescent.
10. Portion of Cockburn Sound Location 550 being part of the land the subject of plan 13066 and being part of the land within Certificate of Title Volume 1554 Folio 701 and the land contained therein be allocated to the adjoining lot 405 Honeysett Court and lot 408 Fluellen Way.
11. Portion of Cockburn Sound Location 550 being part of the land the subject of Diagram 58137 and being part of the land within Certificate of Title Volume 1555 Folio 331 and the land contained therein be allocated to the adjoining lots 424-430 Rodd Place and Lot 419 Erpingham Road.
12. Portion of Cockburn Sound Location 550 being part of the land the subject of Plans 13066 and 13021 and being part of the land within Certificate of Title Volume 1554 Folio 701 Volume 1547 Folio 801 and the land contained therein be allocated to the adjoining lot 210 Southwell Crescent.
13. Portion of Cockburn Sound Location 550 being part of the land the subject of Plan 13000 and being part of the land within Certificate of Title Volume 1564 Folio 801 and the land contained therein be allocated to the adjoining lots 472-477 Bourbon Street.
14. Portion of Cockburn Sound Location 550 being part of the land the subject of Plan 13000 and being part of the land within Certificate of Title Volume 1564 Folio 801 and the land contained therein be allocated to the adjoining lots 440-443 and 452-455 Cassio Place.
15. Portion of Cockburn Sound Location 550 being part of the land the subject of Plan 13000 and being part of the land within Certificate of Title Volume 1564 Folio 801 and the land contained therein be allocated to the adjoining lots 460-465 Erpingham Road.

16. Portion of Cockburn Sound Location 550 being part of the land the subject of Diagram 57128 and Plan 13066 and being part of the land within Certificate of Title Volume 1554 Folio 701 and the land contained therein be allocated to the adjoining lot 360 Bevis Place and lot 188 Owen Place, as shown in the Schedules hereunder.

P. FELLOWES,
Secretary for Local Government.

Schedules.

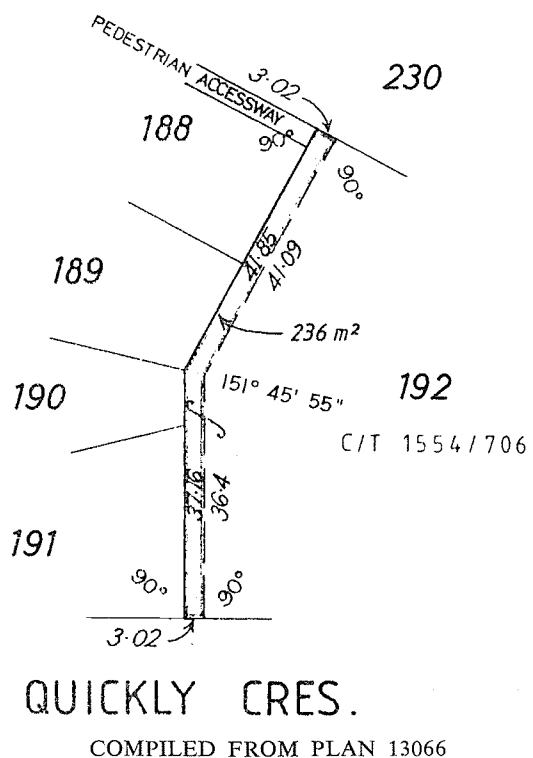
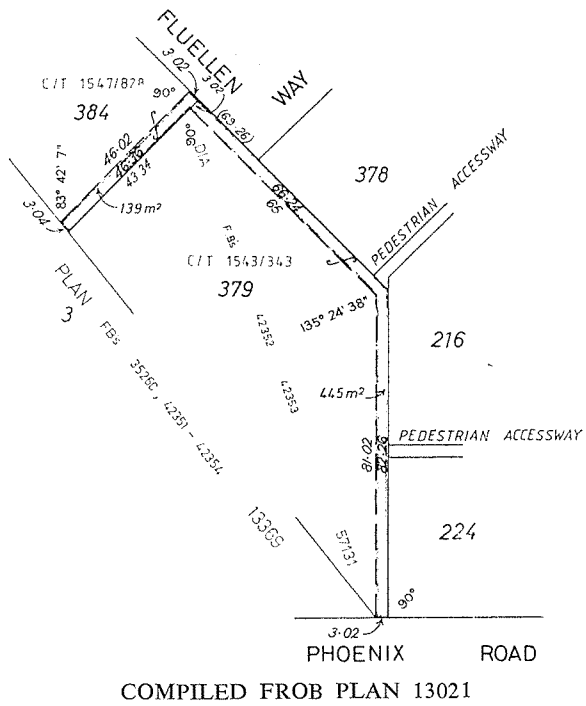

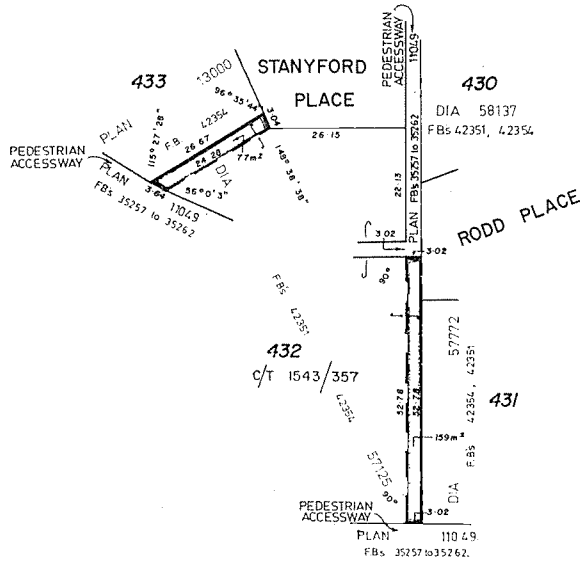

COMPILED FROM PLAN 13000, DIAGS 57125, 57772 and 58137

QUICKLY CRES.

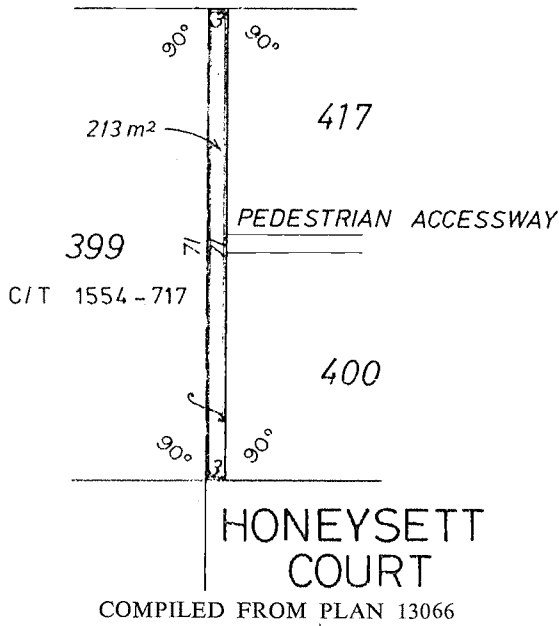

COMPILED FROM PLAN 13066

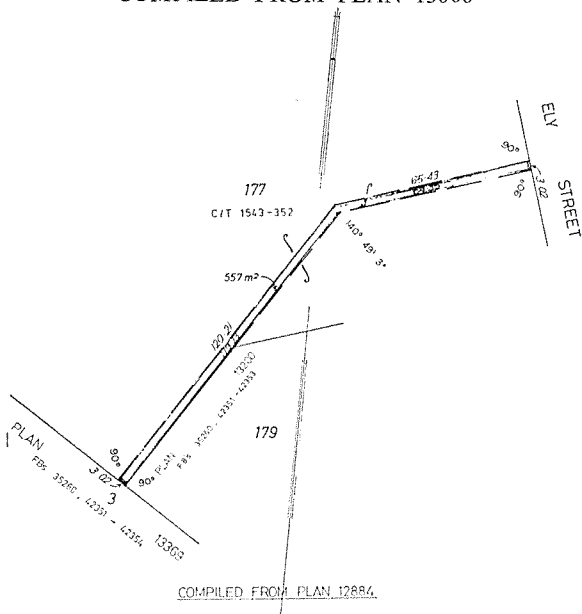

COMPILED FROM PLAN 12884.

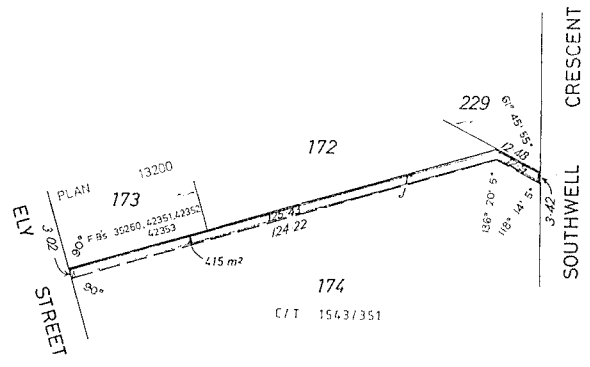

COMPILED FROM DIAGRAM 57126

QUICKLY CRES.

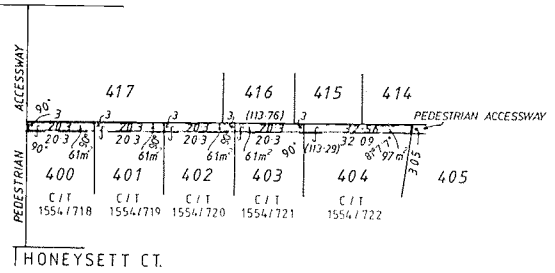

COMPILED FROM PLAN 13066

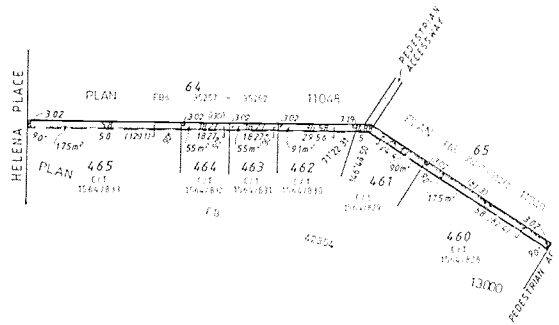

COMPILED FROM PLANS 11048, 11049, AND 13000

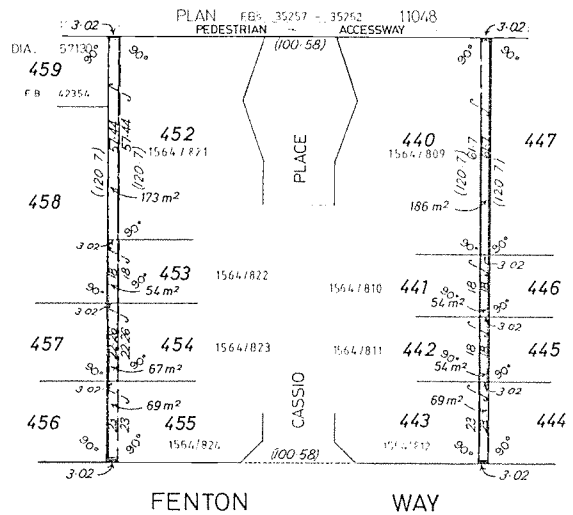

COMPILED FROM PLAN 13000

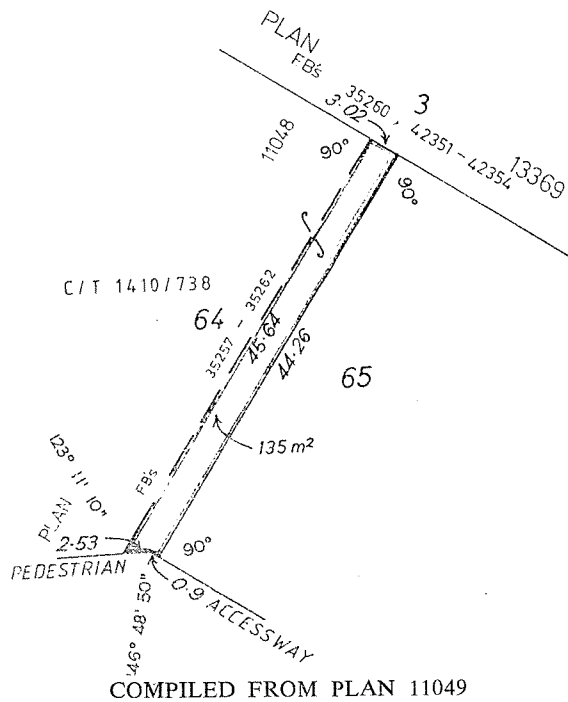
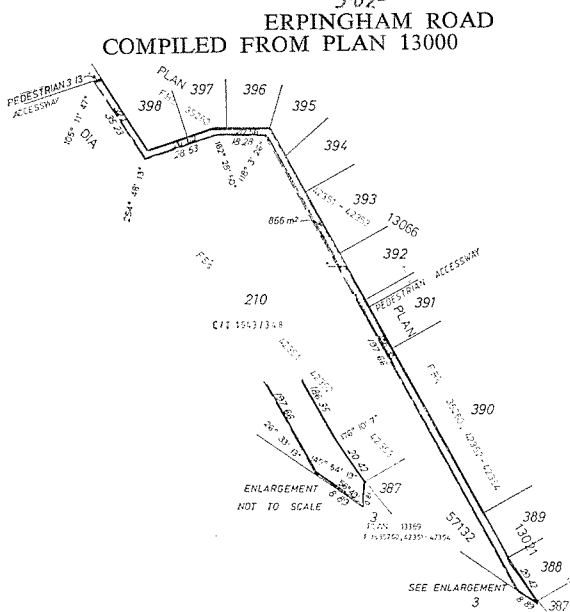
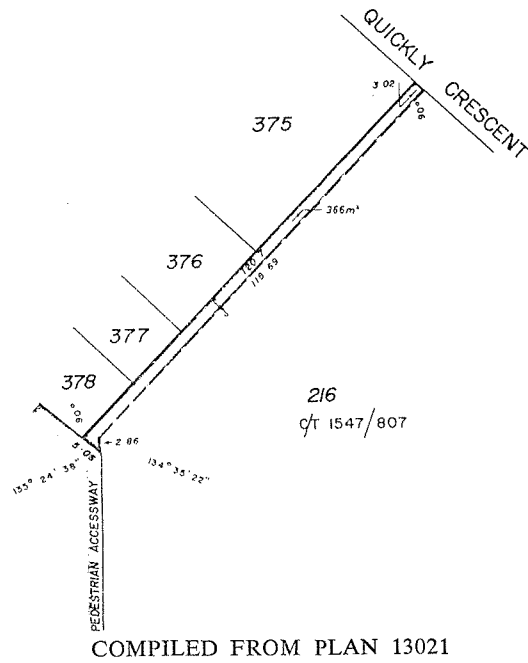
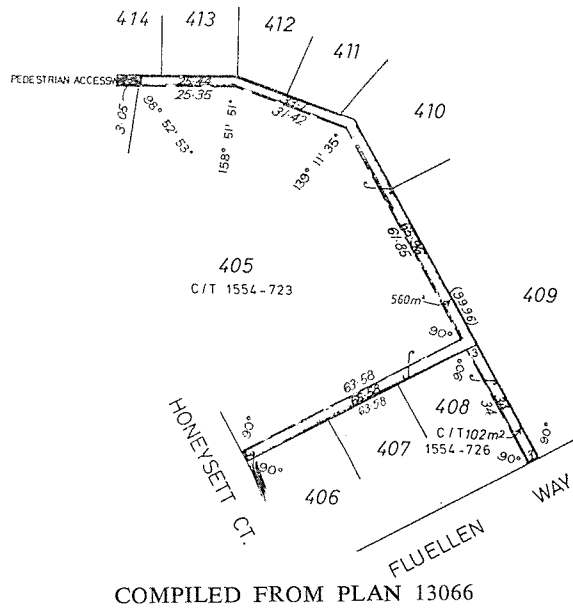
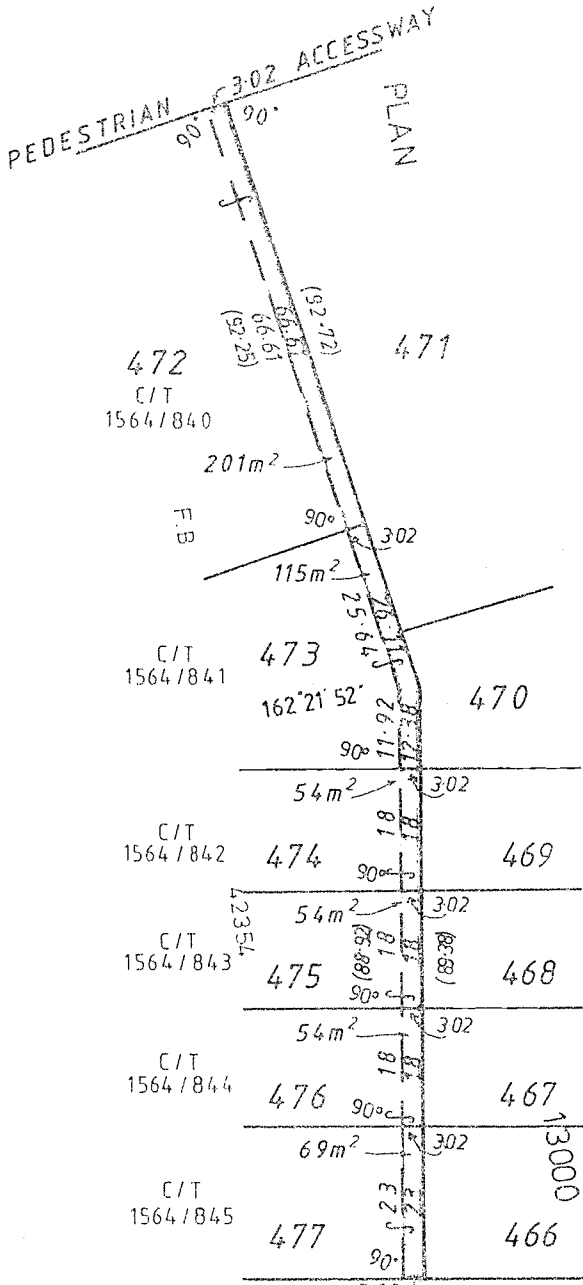

Pedestrian accessway coloured brown hereon appurtenant only to the land the subject of plan 13066.

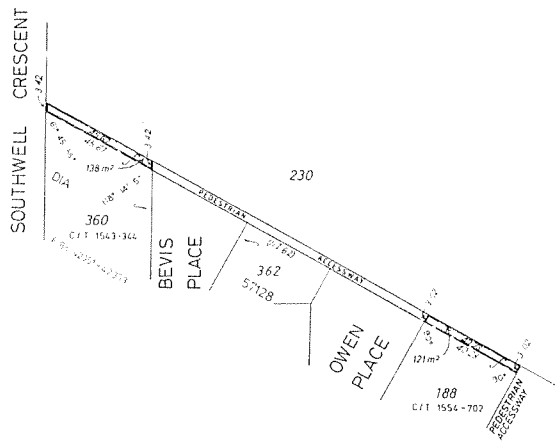

COMPILED FROM PLAN 13066

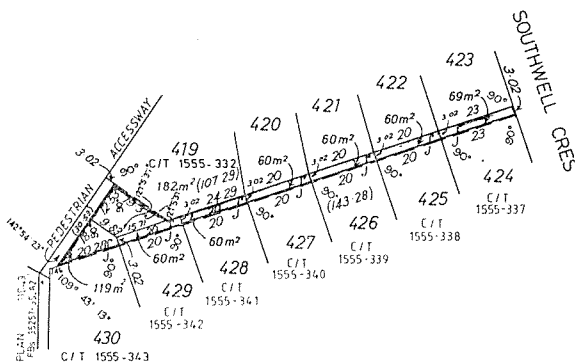

COMPILED FROM DIAGRAM 58137

LOCAL GOVERNMENT ACT 1960-1980.

City of Stirling.

Closure of Private Street.

Department of Local Government,
Perth, 18 February 1981.

LG: ST-4-12D.

IT is hereby notified for public information that His Excellency the Governor has approved under the provisions of section 297A of the Local Government Act 1960-1980, the resolution passed by the City of Stirling that portion of the private street which is described as being portion of Swan Location Y and being portion of the land coloured brown on Diagram 1733 being part of the land comprised in Certificate of Title Volume 282 Folio 153 be closed and the land contained therein be allocated to the adjoining Lots 6-9 Fourth Avenue and Lot 343 Conroy Street, Maylands, as shown in the Schedule hereunder.

P. FELLOWES,
Secretary for Local Government.

Schedule.
(Diagram 60835.)

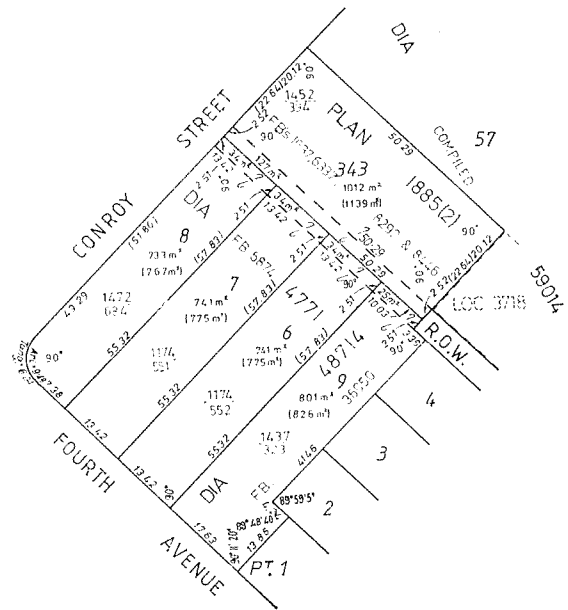

COMPILED FROM DIA's 4771 and 48714 and PLAN 1885(2)

LOCAL GOVERNMENT ACT 1960-1980.

Shire of Narembeen.

Closure of Private Street.

Department of Local Government,
Perth, 18 February 1981.

LG: NB-4-12.

IT is hereby notified for public information that His Excellency the Governor has approved under the provisions of section 297A of the Local Government Act 1960-1980, the resolution passed by the Shire of Narembeen that the private street which is described as being portion of Avon Location 21205 and being the land coloured green and marked "Right of Way" on diagram 9413 and being the land contained in Certificate of Title Volume 1036 Folio 190 be closed and the land contained therein be allocated to the adjoining Lot 36 Thomas Street and Lot 41 Doreen Street, Narembeen as shown in the Schedule hereunder.

P. FELLOWES,
Secretary for Local Government.

Schedule.
(Diagram 60884.)

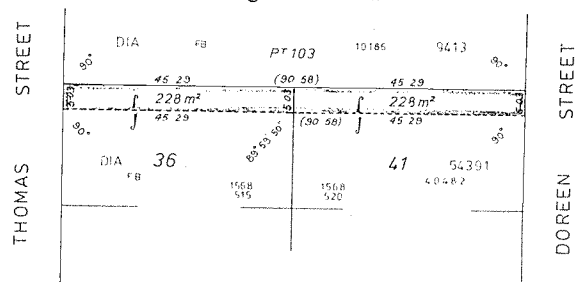

COMPILED FROM DIA's 9413 and 54391

INDUSTRIAL ARBITRATION ACT 1979-1980.

Notice of Appointment of Chief Industrial
Commissioner of the Industrial
Arbitration Commission.

HIS Excellency the Governor in Executive Council has under sections 8 and 9 of the Industrial Arbitration Act 1979-1980 been pleased to appoint, by Commission in Her Majesty's name, Eric Robert Kelly, Esquire, Chief Industrial Commissioner of The Western Australian Industrial Commission established under the Industrial Arbitration Act 1979-1980.

By His Excellency's Command,

J. E. A. PRITCHARD,
Acting Clerk of the Council.

INDUSTRIAL ARBITRATION ACT 1979-1980.

Notice of Appointment of Senior Industrial
Commissioner of the Industrial Arbitration
Commission.

HIS Excellency the Governor in Executive Council has, under section 8 of the Industrial Arbitration Act 1979-1980, been pleased to appoint, by Commission in Her Majesty's name, Donald Edmund Cort, Esquire, Senior Industrial Commissioner of The Western Australian Industrial Commission established under the Industrial Arbitration Act 1979-1980.

By His Excellency's Command,

J. E. A. PRITCHARD,
Acting Clerk of the Council.

INDUSTRIAL ARBITRATION ACT 1979-1980.

Notice of Appointment of Commissioner of the
Western Australian Industrial Commission.

HIS Excellency the Governor in Executive Council has under section 8 of the Industrial Arbitration Act 1979-1980, been pleased to appoint, by Commission in Her Majesty's name, Gavin Leonard Fielding, Esquire, Commissioner of The Western Australian Industrial Commission established under the Industrial Arbitration Act 1979-1980.

By His Excellency's Command,

J. E. A. PRITCHARD,
Acting Clerk of the Council.

AGRICULTURAL PRODUCTS ACT 1929-1974.

Department of Agriculture,
South Perth, 26 March 1981.

Agric. 571/69.

ACTING pursuant to the powers conferred upon me under section 3A of the Agricultural Products Act 1929-1974, I, the undersigned Minister for Agriculture, do hereby appoint the following persons as members of the Apple Sales Advisory Committee constituted under the said Act for a period terminating on 6 March 1984:—

- (1) James Patrick Fallon, nominee of the Director of Agriculture, who shall be the Chairman of the Committee.
- (2) Great Southern District—
Stanley James Mentha of Kendenup.
Deputy—Richard Henry De Pledge of Kendenup.
- South Western District—
 - (i) James Peter Awcock of Bridgetown.
Deputy—Neil Fontanini of Manjimup.
 - (ii) Norman Francis Lindsay of Greenbushes.
Deputy—A. J. Licciardello of Newlands.

Hills District—

Vincent Mazzardis (Jnr.) of Kalamunda.

Deputy—R. A. Sala-Tenna of Carmel.

Nominees of the Western Australian Fruit Growers' Association (Inc.).

- (3) Neville John Pratt.

Deputy—Derek Alwyn Godbold.

Nominees of the Chamber of Fruit and Vegetable Industries of Western Australia (Inc.).

- (4) Joseph John Maffina.

Deputy—Peter Edward Phillips.

Nominees of the W.A. Fruit Shippers' Committee.

- (5) Dale Leslie Watkins as representative of the consumers.

R. C. OLD,
Minister for Agriculture.

AGRICULTURAL PRODUCTS ACT 1929-1974.

Department of Agriculture,
South Perth, 26 March 1981.

Agric. 973/69.

ACTING pursuant to the powers conferred upon me under section 3B of the Agricultural Products Act 1929-1974, I, the undersigned Minister for Agriculture, do hereby appoint the following as members of the Citrus Sales Advisory Committee constituted under the said Act for a period terminating on 6 March 1984:—

- (1) James Patrick Fallon, nominee of the Director of Agriculture, who shall be the Chairman of the Committee.
- (2) Gilbert Leonard Beales of Lower Chittering.
Deputy—Ernest William Parkinson of Bindoon.
J. M. Lowe of Harvey.
Deputy—R. C. Fawcett of Serpentine.
Alexander Thomas Niven of Pickering Brook.
Deputy—D. H. Dell of Kalamunda.
Nominees of the Central Citrus Council of the Western Australian Fruit Growers' Association (Inc.).
- (3) Roy Basil Helliar.
Deputy—Robert Duncan Mercer.
Nominees of the Chamber of Fruit and Vegetable Industries in Western Australia (Inc.).
- (4) Dale Leslie Watkins, as representative of the consumers.

R. C. OLD,
Minister for Agriculture.

CHICKEN MEAT INDUSTRY ACT 1977.

I, THE undersigned Minister for Agriculture, being the Minister charged with the administration of the Chicken Meat Industry Act 1977, acting in exercise of the power in this behalf conferred upon me by sections 7 and 8 of the said Act, do hereby notify:—

- (1) the termination of the appointment of Mr. John Craig as a member and Chairman of the Chicken Meat Industry Committee; and
- (2) the appointment of Mr. Peter Smetana as a member and Chairman of the said Committee pursuant to section 7 (1) (a) of the said Act for a period ending on 16 October, 1981.

Dated this 2nd day of April, 1981.

R. C. OLD,
Minister for Agriculture.

STATE TENDER BOARD OF WESTERN AUSTRALIA.

Tenders for Government Supplies

Date of Advertising	Schedule No.	Supplies Required	Date of Closing
1981			
Mar. 20	102A/1981	Groceries to various Government Institutions (1 year period)	1981 Apr. 9
Mar. 20	194A/1981	Combine Dressing Rolls and Cotton Wool (from date of acceptance of tender to 25/2/82) (recall of Schedule No. 843A/1980)—Various Government Departments	Apr. 9
Mar. 20	200A/1981	Renal Dialysis Machines (1 off to 10 off)—Sir Charles Gairdner Hospital	Apr. 9
Mar. 20	202A/1981	Soap, Soap powders, bleaches, cleansers, metal and furniture polish, etc. (1 year period)—Various Government Departments	Apr. 9
Mar. 20	203A/1981	Class 5B Crawler Dozers with ancillary equipment (one off to 5 off)—M.R.D.	Apr. 9
Mar. 20	204A/1981	Two-Way UHF Radio System—Dept. of Agriculture	Apr. 9
Mar. 13	181A/1981	Horizontal Splitcasing water pumpset (1 only) for Hamilton Hill High Level Area—M.W.B.	Apr. 16
Mar. 27	211A/1981	Ball Point Pens (1 year period)—Government Stores Department	Apr. 16
Mar. 27	220A/1981	Firewood to Perth, Fremantle, Midland, Gosnells and Serpentine (12 month period)	Apr. 16
Mar. 27	221A/1981	Semi Trailer Dollies (9 only)—M.R.D.	Apr. 16
Mar. 27	222A/1981	Lime Putty (period 16/8/81 to 30/6/82)—approx. 2 100 m ³ —M.W.B.	Apr. 16
Feb. 13	90A/1981	Grit Collection and Removal Equipment for Point Peron Wastewater Treatment Plant Extensions—M.W.B.	Apr. 30
Feb. 13	91A/1981	Screening and Screening Processing Equipment for Point Peron Wastewater Treatment Plant Extensions—M.W.B.	Apr. 30
Mar. 27	100A/1981	Drugs and Ethical Preparations (1 year period) July 1, 1981 to June 30, 1982—various Government Hospitals and Institutions	Apr. 30
Apr. 3	240A/1981	Variable Speed Return Activated Sludge Pumping Units (6 only) plus Matched Starters, Speed Controllers and Spare Parts for Beenyup Waste-Water Treatment Plant—M.W.B.	Apr. 30
Apr. 3	241A/1981	Patrol Vessel (12.9 metre) (1 only)—Police Department	Apr. 30
Apr. 3	242A/1981	Storage/Mess Caravans (5 only)—M.W.B.	Apr. 30
<i>Service Required</i>			
Apr. 3	227A/1981	Recharging Government Owned Cylinders with Acetylene Gas and Cylinder Servicing—(1 year period)	Apr. 30

For Sale by Tender

Date of Advertising	Schedule No.	For Sale	Date of Closing
1981			
Mar. 20	190A/1981	Ropa Office Type Caravan (MRD 754) at Derby	Apr. 9
Mar. 20	191A/1981	C.P. Paving Breaker (PW 572) at Meekatharra	Apr. 9
Mar. 20	193A/1981	Stihl Chainsaws (7 only) at Dwellingup	Apr. 9
Mar. 20	195A/1981	Lincoln 400AS Welder (PW 252) at Geraldton	Apr. 9
Mar. 20	197A/1981	Holden HX Station Sedan (UQZ 481) at South Hedland	Apr. 9
Mar. 20	201A/1981	McCulloch Chainsaws (3 only) and Stihl Chainsaw (1 only) at Harvey	Apr. 9
Mar. 27	205A/1981	1952 Leyland Prime Mover (UQG 437) and Low Loader (UQU 628) (re-called) at East Perth	Apr. 9
Mar. 27	206A/1981	Dodge 690 HN8 Crew Cab Truck (MRD 461) at East Perth	Apr. 9
Mar. 27	207A/1981	Ford D400/D810 Truck (MRD 1191) at East Perth	Apr. 9
Mar. 27	208A/1981	Boltons Mobile Kitchen Caravan (MRD 437) at East Perth	Apr. 9
Mar. 27	210A/1981	1977 Holden HX Panel Van (1 only); 1977 Toyota FJ45 Utility (1 only); 1977 Toyota FJ55 Station Wagon (1 only); 1977 Suzuki LJ50 Vans (2 only) and 1977 Toyota FJ55 Van (1 only) at Forrestfield	Apr. 9
Mar. 27	209A/1981	Holden HZ Sedan (XQE 734) at Broome	Apr. 16
Mar. 27	212A/1981	1977 Dodge D5N Truck (XQD 086) (recalled) at Wyndham	Apr. 16
Mar. 27	213A/1981	Holden HZ Station Sedan (XQE 085) at Wyndham	Apr. 16
Mar. 27	214A/1981	1977 Galant XL Station Sedan (UQS 174) at Kalgoorlie	Apr. 16
Mar. 27	215A/1981	Holden HX One Tonne (UQY 955) at Carnarvon	Apr. 16
Mar. 27	216A/1981	1973 Dodge Prime Mover and 1967 Mack Prime Mover at Manjimup	Apr. 16
Mar. 27	217A/1981	Stihl Chainsaws (2 only 075 models and 1 only 020 model) at Jarrahdale	Apr. 16
Mar. 27	218A/1981	5 000 Litre Fibreglass Tank and Steel Stand at Jarrahdale	Apr. 16
Mar. 27	219A/1981	Cromco Robin EY 18-30 Plate Compactor (PW 21) at South Hedland	Apr. 16
Mar. 27	223A/1981	1975 Holden HJ Utilities (2 only) and 1973 Holden HQ Utilities (2 only) at Collie	Apr. 16
Mar. 27	224A/1981	1967 Bedford 3 ton Tray Top Truck (UQE 635) at Ludlow	Apr. 16
Mar. 27	225A/1981	Holden Torana Sedan (1 only); Toyota SWB (1 only) Daihatsu 4 x 4 (1 only); Holden Utilities (4 only); Falcon Van (1 only) at Manjimup	Apr. 16
Mar. 27	226A/1981	1959 Massey Ferguson Tractor (UQE 736) at Jarrahdale	Apr. 16
Apr. 3	228A/1981	Vertical Meihle Letter Press Printing Machines (2 only) and Nebiola Saturating RTU Letter Press Printing Machine at Wembley	Apr. 16
Apr. 3	230A/1981	1974 Mini Van (1 only); 1978 Ford F100 Utility (1 only); 1972 Holden HQ Utility (1 only); 1974 Holden HJ Utility (1 only); 1976 Holden HJ Utility (1 only); 1974 Holden HQ Utilities (8 only) and 1976 Daihatsu 4 x 4 Vans (3 only) at Gnangara	Apr. 16
Apr. 3	232A/1981	1973 Boltions Mobile Kitchen Caravan (PW 188) at East Perth	Apr. 16
Apr. 3	233A/1981	1977 Datsun Patrol Van (MRD 1949) Re-called at East Perth	Apr. 16
Apr. 3	234A/1981	Flumo Professional MK II Lawn Mower (MRD 482) at East Perth	Apr. 16

STATE TENDER BOARD OF WESTERN AUSTRALIA—*continued**For Sale by Tender—continued*

Date of Advertising	Schedule No.	For Sale	Date of Closing
Apr. 3	235A/1981	Rotomobile Soil Stabilizer (MRD 428) at East Perth	Apr. 16
Apr. 3	239A/1981	1969 and 1972 Massey Ferguson Forwarders (2 only) and 1975 International 392 C.I. V8 Engine at Gnangara	Apr. 16
Apr. 3	229A/1981	Toyota FJ45 Land Cruiser Panel Vans (2 only)—Recalled at Derby	Apr. 30
Apr. 3	231A/1981	Holden HX Station Sedan (1 only); Holden HX Sedan (1 only) and Holden HZ Station Sedan (1 only) at Karratha	Apr. 30
Apr. 3	236A/1981	Holden HZ Station Sedans (2 only) at Wyndham	Apr. 30
Apr. 3	237A/1981	Toyota Land Cruiser Station Sedan (XQD 401) at Karratha	Apr. 30
Apr. 3	238A/1981	Dodge D5N Van (MRD 1873) and Dodge D5N Flat Top (MRD 2132) at Kununurra	Apr. 30

Tenders addressed to the Chairman, State Tender Board, 74 Murray Street, Perth, will be received for the abovementioned schedules until 10 a.m. on the dates of closing.

Tenders must be properly endorsed on envelopes otherwise they are liable to rejection.

Tender forms and full particulars may be obtained on application at the Tender Board Office, 74 Murray Street, Perth and at points of inspection.

No Tender necessarily accepted.

B. E. CORBOY,
Chairman, Tender Board.

ACCEPTANCE OF TENDERS

Schedule No.	Contractor	Particulars	Department Concerned	Rate
901A/80	Amalgamated Wire-less (Australia) Ltd.	Supply, Delivery, Installation and Commissioning of Data Entry Equipment	Government Stores	Details on application
32A/81	Dunlop Industrial	Supply and Delivery of Vacuum Brake Rubber Components	Westrail	Details on application
34A/81	International Harvester Australia Ltd.	Supply and Delivery of Two (2) only International Tip Trucks Less Trade-in allowance on (a) 1974 International Tip Trucks (UQR 434) and (UQR 709)	M.W.B.	\$102 798 \$22 000 Total Cost \$80 798
47A/81	Ryan Forklift Sales	Supply and Delivery of one (1) only Forklift Truck, 4 000 kg	Westrail	\$33 929
88A/81	Altona Engineering Co.	Supply and Delivery of one hundred and sixty-eight (168) only Retroreflective Guide Sign Panels (587 m ²) 571.8 m ² Standard Green Scotchcal Finish 15.5 m ² Aircraft Blue and Leaf Brown Finish	M.R.D.	\$78.93 per m ² \$75.98 per m ²
138A/81	Altona Engineering Co.	Supply and Delivery of 24 000 sets of Western Australian Private Motor Vehicle Plates	R.T.A.	\$2.28 per set of two
<i>For Sale</i>				
59A/81	C.F.C. Holdings P/L	Purchase and Removal of secondhand Dodge Cab and Chassis (MRD 1823) at East Perth	M.R.D.	For the sum of \$580
77A/81	R. Allison	Purchase and Removal of Secondhand Ropa Caravan (Reg. No. UQU 606) at Meekatharra	P.W.D.	For the sum of \$1 250
93A/81	Weber Holdings	Purchase and Removal of Secondhand Generator, 25 kVA, 440 volts, 34 amps, with Air Cooled Deutz Motor	Community Welfare	For the sum of \$5 000
110A/81	H. L. Young	Purchase and Removal of Secondhand Ings Ride On Lawnmower (PW 3) at Kununurra	P.W.D.	For the sum of \$150
111A/81	C. R. Peake	Purchase and Removal of Secondhand Honda Generator, 4kVA 12 volt, Honda Diesel Engine at South Hedland	P.W.D.	For the sum of \$195
112A/81	R. G. Machinery	Purchase and Removal of Secondhand Bulldozer Caterpillar (Reg. No. UQE 543) at Mundaring	Forests	For the sum of \$10 001
124A/81	C. D. Dodd	Purchase and Removal of 782 only concrete slabs at Government Stores Dept., Royal Street, East Perth and 2 280 only Concrete slabs at Delta Corporation Pty. Ltd. Campersic Road, Herne Hill	P.W.D.	For the sum of \$1 673.60
146A/81	J. W. Robinson	Purchase and Removal of Secondhand Holden Station Sedan (Reg. No. UQZ 827) at Carnarvon	P.W.D.	For the sum of \$1 855
148A/81	Ray Mack Motors	Purchase and Removal of: Item 2: Secondhand Holden Station Sedan (Reg. No. XQE 624) at South Hedland	P.W.D.	For the sum of \$1 633

STATE TENDER BOARD OF WESTERN AUSTRALIA—*continued*
ACCEPTANCE OF TENDERS—*continued*

Schedule No.	Contractor	Particulars	Department Concerned	Rate
	R. Elnimere	Item 3: Secondhand Holden Station Sedan (Reg. No. UQZ 944) at South Hedland		For the sum of \$965
149A/81	K. Morris	Purchase and Removal of Secondhand Holden Station Sedan (Reg. No. UQZ 344) at Wyndham	P.W.D.	For the sum of \$1 875
150A/81	Ray Mack Motors	Purchase and Removal of Secondhand Holden Gemini Sedan (Reg. No. XQC 614) at Geraldton	P.W.D.	For the sum of \$2 333
152A/81	C. Sells	Purchase and Removal of Secondhand Holden Utility (Reg. No. XQD 353) at Karratha	P.W.D.	For the sum of \$2 700
155A/81	A. Fissioll	Purchase and Removal of Secondhand Dodge Truck (MRD 1161) at Kalgoorlie	M.R.D.	For the sum of \$600
156A/81	Soltoggio Bros.	Purchase and Removal of Secondhand Dodge Truck (MRD 374) at Kalgoorlie	M.R.D.	For the sum of \$466
165A/81	R. T. & P. A. Cole	Purchase and Removal of Secondhand Toyota Tipper Truck (MRD 890) at East Perth	M.R.D.	For the sum of \$1 555
167A/81	Bob Hunter & Co.	Purchase and Removal of Secondhand Land Rover (MRD 1653) at East Perth	M.R.D.	For the sum of \$1 676
169A/81	J. E. Nash	Purchase and Removal of Secondhand Dodge Travelling Mechanics Van (MRD 927) at East Perth	M.R.D.	For the sum of \$1 523
171A/81	Soltoggio Bros.	Purchase and Removal of Secondhand Dodge 2-3 Ton Truck (MRD 1347) at East Perth	M.R.D.	For the sum of \$888
172A/81	Eastway Motors	Purchase and Removal of Secondhand Dodge Crew Cab Truck (MRD 459) at East Perth	M.R.D.	For the sum of \$1 866
<i>All Tenders Declined</i>				
924A/80		Supply and Delivery of Biscuits and Cake (1981-82)	Various	
41A/81		Purchase and Removal of 1977 Datsun Patrol Van (MRD 1949) and 1976 Nissan 60 Patrol (MRD 1661) at East Perth	M.R.D.	
117A/81		Purchase and Removal of Baravan 16 ft 2-Berth Caravan (UQU 857) at Derby	P.W.D.	
122A/81		Purchase and Removal of: Item 1: Secondhand Ford Utility (Reg. No. XQI 319) Item 3: Secondhand Toyota Landcruiser Panel Van (Reg. No. UQS 334) Item 4: Secondhand Toyota Landcruiser Panel Van (Reg. No. UQS 583) at Derby	P.W.D.	
143A/81		Purchase and removal of 1973 Boltons Mobile Kitchen Caravan (PW 188) at East Perth	P.W.D.	

MAIN ROADS DEPARTMENT
ACCEPTANCE OF TENDERS

Tender No.	Description	Successful Tenderer	Amount
99/80	Bituminous Sealing and Resealing—Esperance Area	Spraypave Pty Ltd	\$ 67 988
141/79	Road Construction—Blowholes Road, Shire of Carnarvon	Bond Resources	2 393 490

GOVERNMENT PRINTING OFFICE OF W.A.
TENDERS FOR GOVERNMENT PRINTING

Tenders are invited for the supply of the undermentioned stores.
Tenders close at Wembley, at 10.00 a.m. on 13th April 1981.

Tender No.	Description	Size
CP 9438	200 books of 50 in triplicate	204 x 262 mm
CP 9471	20 000 cards of two kinds	205 x 380 mm
CP 9472	10 books of 25 in duplicate	300 x 220 mm
CP 9477	50 000 two-part fanapart sets	330 x 410 mm

SPECIAL NOTE—STOCK:

Tenderers are requested to specify—

1. Country of Origin.
2. Brand or make of material.
3. In this contract preference may be given to W.A. or other Australian made stocks in accordance with Government Policy.

ACCEPTANCE OF TENDERS

Tender No.	Particulars of Stores	Successful Tenderer	Amount
CP 9344	10 800 pads	Compact	\$ 920.00
CP 9351	2 000 single forms	Pilpel & Co.	45.80
CP 9354	50 Books of 50 in duplicate	Swan Print	90.00
CP 9356	2 000 two-part fanapart sets	Swan Print	102.00
CP 9357	100 books of 100 leaves	Swan Print	150.00
CP 9388	30 books of 50 in quadruplicate	Swan Print	145.00
CP 9387	100 pads of 100 fanapart sets in dup.	Swan Print	275.00
CP 9394	20 pads of 50 in duplicate	Pilpel & Co.	109.60
CP 9395	50 books of 50 in quadruplicate	Swan Print	260.00
CP 9396	50 books of 50 in quadruplicate	Swan Print	260.00

WILLIAM C. BROWN,
Government Printer.

APPOINTMENTS.

(Under section 6 of the Registration of Births, Deaths and Marriages Act 1961-1979.)

Registrar General's Office,
Perth, 30 March 1981.

THE following appointments have been approved:—

R.G. No. 108/72.—Senior Constable Kevin Joseph Bell has been appointed as Assistant District Registrar of Births and Deaths for the Gascoyne Registry District to maintain an office at Shark Bay during the absence on leave of Senior Constable J. R. Standing. This appointment dates from 30 March 1981 to 17 May 1981.

R.G. No. 43/72.—Mr. Ernest William Dwyer has been appointed as District Registrar of Births, Deaths and Marriages for the Swan Registry District to maintain an office at Midland pending a permanent appointment due to the retirement of Mr. A. N. Dean. This appointment dated from 23 March 1981.

E. C. RIEBELING,
Registrar General.

COMPANIES ACT 1961-1979.

(Section 272.)

Notice of Final Meeting of Members.

W. Dunlop & Co. Pty. Ltd.

NOTICE is hereby given that the Final Meeting of Members of W. Dunlop & Co. Pty. Ltd. will be held at the offices of Messrs. C. P. Bird & Associates, 18

(3)—11361

St. George's Terrace, Perth on the 30th April 1981 at 9.00 o'clock in the forenoon.

Agenda:

(1) To lay before the meeting the Liquidator's Account showing how the property of the company has been disposed of, and giving any explanation thereof.

(2) To approve the liquidator's remuneration.

Dated at Perth this 24th day of March, 1981.

N. E. GUTHRIE,
Liquidator.

(Messrs. C. P. Bird & Associates, Chartered Accountants, 18 St. George's Terrace, Perth.)

IN THE SUPREME COURT OF WESTERN AUSTRALIA.

Petition No. 11 of 1978.

In the matter of the Companies Act and Amendments and in the matter of Sacca Distributors Pty. Ltd. NOTICE is hereby given that a petition for the winding up of the abovenamed company by the Supreme Court was, on the 11th day of March, 1981 presented by Reyco Ingersoll Pty. Ltd. and that the said petition is directed to be heard before the Court sitting at Perth at the hour of 10.30 o'clock in the forenoon on the 6th day of May 1981 and any creditor or contributory of the said company desiring to support or oppose the making of an order on the said petition may appear at the time of hearing by himself or his counsel for that purpose; and a copy of the petition will be furnished to any

creditor or contributory of the said company requiring the same by the undersigned on payment of the regulated charge for the same.

The petitioner's address is 330 Lower Dandenong Road Mordialloc in the State of Victoria.

The petitioner's solicitors are Messrs Stone James & Co of Law Chambers Cathedral Square Perth aforesaid.

STONE JAMES & CO.,
Solicitors for the Petitioner.

NOTE: Any person who desires to appear on the hearing of the said petition must serve on or send by post to the abovenamed Messrs Stone James & Co notice in writing of his intention so to do. The notice must state the name and address of the person, or, if a firm, the name and address of the firm, and must be signed by the person or firm, or his or their solicitor (if any), and must be served, or, if posted, must be sent by post in sufficient time to reach the abovenamed, not later than four o'clock in the afternoon of the 5th day of May 1981.

COMPANIES ACT 1961-1979.

NOTICE of Winding up Order in the Matter of Tygran Pty. Ltd.

Winding up order made the 17th day of October, 1980.

Name and address of Liquidator: Albert Roy Wright, c/o C. P. Bird & Associates, 18 St. George's Terrace, Perth.

LAVAN & WALSH,
Solicitors for the Petitioner.

COMPANIES ACT 1961-1979.

(Section 260 (2).)

Notice of Meeting of Creditors.

K.G. Maintenance Contractors Pty. Ltd.

NOTICE is hereby given that, pursuant to section 260 (2) of the Companies Act 1961-1979 a meeting of creditors of K.G. Maintenance Contractors Pty. Ltd. will be held at the Boomerang Hotel, 1120 Albany Highway, Bentley, on Tuesday 14 April 1981 at 11.00 a.m. to consider the following proposed resolution to be placed before and considered by an Extraordinary General Meeting of Shareholders of the company to be held at 10.45 a.m. on the same day:—

That the Company be wound up voluntarily and that Mr. N. F. V. Curtis, Chartered Accountant of 1 Kalamunda Road, Kalamunda be and is now appointed liquidator of the Company.

A person is not entitled to vote as a creditor at the meeting unless he has lodged with the Chairman of the meeting or the Company a valid claim of the debt which he considers is due to him from the Company.

Dated at Kalamunda this 27th day of March, 1981.

K. G. BLACK,
Director.

N.B. A creditor entitled to attend and vote at this meeting may appoint another person (whether a creditor or not) as his proxy to attend and vote in his stead.

COMPANIES ACT 1961-1979.

(Section 272 (2).)

Broadway Investments Pty. Ltd. (In Liquidation).

Notice of Final Meeting.

NOTICE is hereby given that the Final Meeting of members of the above company will be held at the offices of Coopers & Lybrand, Fifth Floor, 220 St. George's Terrace, Perth in the State of Western Australia on the 27th day of May, 1981, at 10 a.m. for the purpose of laying before the meeting an account showing how the winding up has been conducted and the property of the company has been disposed of and giving any explanation thereof.

Dated this 23rd day of March, 1981.

M. A. LEVI,
Liquidator.

(Coopers & Lybrand, 5th Floor, 220 St. George's Terrace, Perth, 6000.)

COMPANIES ACT 1961 (AS AMENDED).

In the Matter of the Companies Act 1961 (as Amended) (Section 272) and Diwa Pty. Ltd. (in Voluntary Liquidation).

NOTICE is hereby given that the final general meeting of members of Diwa Pty. Ltd. (in voluntary liquidation) will be held at the offices of Touche Ross & Co., Level 42 MLC Centre, Martin Place, Sydney on 8 May 1981 at 10.00 a.m., for the purpose of laying before the meeting an account showing how the winding-up is being conducted and the property of the company has been disposed of and giving an explanation of the account.

Dated at Sydney this 23rd day of March, 1981.

G. O. HARRISON,
Liquidator.

(C/o Touche Ross & Co., 42 Level, MLC Centre, Martin Place, Sydney.)

COMPANIES ACT 1961-1979.

(Section 260 (1).)

Notice of Meeting of Creditors to Consider Winding Up.

Resolution.

Sea Mar Nominees Pty. Ltd.

NOTICE is hereby given that pursuant to subsection 1 of section 260 of the Companies Act 1961-1979, a meeting of creditors of Sea Mar Nominees Pty. Ltd. Trustee for the Sea Mar Unit Trust trading as Laguna Marine (1978) will be held at Level 3, 58 Ord Street, West Perth on the 10th day of April, 1981, at 10.00 a.m.

The meeting is convened for the purpose of considering the position of the company's affairs, the company having convened an extraordinary general meeting of its members to be held on the same day for the purpose of considering and if deemed expedient passing an extraordinary resolution to winding up the company voluntarily and to nominate Michael John Barry, Chartered Accountant, of Level 3, 58 Ord Street, West Perth, as Liquidator for the purpose of winding up.

Dated this 30th day of March, 1981.

By Order of the Board,
G. A. C. LAWSON,
Director.

(Barry, Chester & Hick Proprietary, Level 3, 58 Ord Street, West Perth.)

COMPANIES ACT 1961-1979.

(Section 254 (2).)

Mongaming Pty. Ltd.

AT a Meeting of Members of the above company held on the 27th day of March, 1981, the following special resolution was passed:—

THAT the Company be wound up voluntarily and Ian Douglas Ritchie, having consented in writing to act, be and is hereby appointed Liquidator for the purpose of such winding-up, and that the Liquidator be authorised to divide all or such part of the assets of the Company amongst the members of the Company in "specie or kind" as he shall in his discretion think fit and may in his discretion vest any part of the assets of the Company in Trustees upon such trusts for the benefit of the contributories or any of them as the Liquidator shall think fit, notwithstanding that any such assets may be encumbered by mortgage or otherwise and the Liquidator may accept such indemnities with regard thereto as he should think fit.

R. M. MILLER,
Secretary.

COMPANIES (CO-OPERATIVE) ACT 1943-1976.

Notice of Intention to Declare a First and Final Dividend.

Bruce Rock District Farmers Co-Operative Co. Ltd.
(in Liquidation).

NOTICE is hereby given that as Liquidator of the abovenamed Company, I, Rodney Michael Evans, Chartered Accountant of Melsom Wilson & Partners, 11th Floor, T & G Building, 37 St. George's Terrace, Perth, intend to declare a First and Final Dividend in this matter.

Creditors must prove their debts by 17 April 1981.

Dated at Perth this 27th day of March, 1981.

R. M. EVANS,
Liquidator.

(Melsom Wilson & Partners, 11th Floor, T & G Building, 37 St. George's Terrace, Perth, W.A. 6000.)

COMPANIES ACT 1961-1979.

Notice of Intention to Declare a Third and Final Dividend.

Finance Securities (Australia) Ltd.
(in Liquidation).

NOTICE is hereby given that as Liquidator of the abovenamed Company, I, Maurice Hodgson Lyford, Chartered Accountant, of Melsom Wilson & Partners, 11th Floor, T & G Building, 37 St. George's Terrace, Perth, intend to declare a Third and Final Dividend in this matter.

Creditors must prove their debts by 17 April 1981.

Dated at Perth this 27th day of March, 1981.

M. H. LYFORD,
Liquidator.

(Melsom Wilson & Partners, 11th Floor, T & G Building, 37 St. George's Terrace, Perth, W.A. 6000.)

COMPANIES ACT 1961-1979.

(Section 272 (1).)

Notice of Final Meeting of Members and Creditors.

Kewsteel Fabrication Pty. Ltd. (in Liquidation).

NOTICE is hereby given that, pursuant to the provisions of section 272 of the Companies Act 1961-1979, a final meeting of the members and creditors of Kewsteel Fabrication Pty. Ltd. will be held on Tuesday the 12th day of May, 1981 at 11.00 a.m. at the offices of Hungerford Hancock & Offner, 16th Floor, 37 St. George's Terrace, Perth, for the purpose of laying before the meeting an account showing how the winding up has been conducted and the property of the company has been disposed of and of giving any explanation of the account.

Dated at Perth this 1st day of April, 1981.

R. S. NORGARD,
Liquidator.

(Hungerford Hancock & Offner, Chartered Accountants, 16th Floor, T & G Building, 37 St. George's Terrace, Perth, W.A. 6000.)

COMPANIES ACT 1961-1979.

(Section 254.)

Plaimar Limited (in Liquidation).

Industrial Extracts Limited (in Liquidation).

Special Resolution to Wind up.

AT an Extraordinary General Meeting of the abovenamed Company duly convened and held at 7 Sefton Road, Thornleigh, N.S.W. on the 26th day of March, 1981, the following resolution was passed as a Special Resolution:—

That the company be wound up voluntarily.

At the abovementioned meeting Alexander Robert Mackay MacIntosh of Tower Building, Australia Square, Sydney was appointed Liquidator for the purpose of the winding up.

Notice is also given that after twenty-one days from this date, I shall proceed to distribute the assets. All creditors having any claim against the company should furnish particulars of same by that date, otherwise I shall proceed to distribute the assets without regard to their claim.

Dated this 27th day of March, 1981.

A. R. M. MacINTOSH,
Liquidator.

COMPANIES ACT 1961-1979.

(Section 254 (2).)

T.N.C. Holdings Pty. Ltd. (in Voluntary Liquidation).

NOTICE is hereby given that at an Extraordinary General Meeting of the members of the company held on 20 March 1981 the Special Resolution set out below was duly passed:—

That the company be wound up voluntarily and that Mr. Jeremiah Michael Donovan, Chartered Accountant, of 1205 Hay Street, West Perth, W.A., be appointed as liquidator for the purpose of such winding up.

Dated this 30th day of March, 1981.

J. M. DONOVAN,
Liquidator.

DISSOLUTION OF PARTNERSHIP.

NOTICE is hereby given that the partnership existing between Pam Hencz, Steve Hencz, Pauline Margaret Wicks and Warren John Wicks, carrying on business as Earthmoving Essential Repair Co., at 322 Treasure Road, Welshpool, has been dissolved as from 27 March, 1981.

Dated the 30th day of March, 1981.

W. J. WICKS.

TRUSTEES ACT 1962-1968.

CREDITORS and other persons having claims (to which section 63 of the Trustees Act 1962-1968 relates) in respect of the undermentioned deceased persons are required to send particulars of their claims to the Executors of care of Kott Gunning & Co., 22 St. George's Terrace, Perth by the 15th day of May, 1981, after which date the Trustee may convey or distribute the assets having regard only to the claims of which notice has been given.

Williams, Jack Norman, Unit 12, 94 Marine Parade, Cottesloe. Company Director. Date of Death 13/10/80.

Miller, Reginald Goynes, "Wyvern", Karella Street, Nedlands. Chartered Accountant. Date of death 19/10/80.

Stout, Henrietta, 308 Safety Bay Road, Safety Bay, Home Duties. Date of death 26/10/80.

Oddie, Eric Roland, 62 Arcadia Drive, Shoalwater. Naval Officer. Date of death 2/12/80.

Marks, Barbara Florence, 33 Kennard Street, Kensington. Widow. Date of death 9/10/80.

Dorsa, Luigi Eric, 14 Cookham Street, Rivervale. General Manager. Date of death 1/7/80.

Seiver, Gwendoline Ellen, 22 Parklands Street, Riverton. Married Woman. Date of death 25/12/80.

Mills, Leslie Gordon, 5828 Seventh Floor, Woh Hup Complex, Beach Road, Singapore. Builder. Date of death 15/10/80.

Wright, Francis Edward, 469 Leighton Road, Mandurah. Retired Publican. Date of death 6/12/80.

Frichot, Leon Noel, Lot 35 Woodvale Drive, Woodvale. Business Proprietor. Date of death 12/2/81.

Rule, Elsie May, Lefroy Street, Moora. Widow. Date of death 12/12/80.

Campisi, Raffaele Giuseppe, 44 Jones Street, Balcatta. Market Gardener. Date of death 6/1/81.

Fetzer, Joseph Andrew, 105 Penzance Street, Bassendean (also of 208 Middle Swan Road, Caversham). Apiarist. Date of death 25/4/80.

- Fortescue, Eric Dudley, 6 Traylen Road, Bayswater. Motor Mechanic. Date of death 7/6/79.
- Johnstone, John Kerr, Mill Street, Mullewa (also 5 Fenton Place, Myaree). Police Sergeant. Date of death 29/6/80.
- Johnson, Graham Leslie, 26 Walter Road, Inglewood (also 748 Benara Road, Caversham). Caravan Park Proprietor. Date of death 15/6/80.
- Milentis, Mithodos Dimitrou, 275 Hamersley Road, Subiaco. Labourer. Date of death 30/6/80.
- Riatti, Maria Albina, 25 Kelvin Street, Maylands. Married Woman. Date of death 13/10/80.
- Templeman, Harold Robert, 63 Comer Street, Como. Watchmaker. Date of death 16/10/80.
- Broun, William Owen Tyndall, 18A Gloucester Avenue, Safety Bay. Retired Farmer. Date of death 22/10/80.
- Hynam, Helen Mabel Henrietta, 60 Mount Street, Perth. Married Woman. Date of death 12/2/81.

TRUSTEES ACT 1962.

Notice to Creditors and Claimants.

WEST AUSTRALIAN TRUSTEES LIMITED of 135 St. George's Terrace, Perth, requires creditors and other persons having claims (to which section 63 of the Trustees Act 1962 relates) in respect of the estates of the undermentioned deceased persons, to send particulars of their claims to it by the date stated hereunder, after which date the Company may convey or distribute the assets, having regard only to the claims of which it then has notice.

Last Day for Claims: 4/5/81.

- Lidbury, Ethel Florence, late of Parry House, Grove Road, Lesmurdie, Home Duties, died 22/1/81.
- Lymbery, Dilys, late of Palmer Road, Ewington via Collie, Married Woman, died 8/12/80. (Enquiries to 11 Stirling Street, Bunbury Tel: 21 1336.)
- Morfitt, James, late of 2 Davies Street, Beaconsfield, Carpenter, died 3/8/74.
- Smith, Helen Alexandria Louie, late of 8 Gregory Street, Bunbury, Married Woman, died 3/12/80. (Enquiries to 11 Stirling Street, Bunbury Tel: 21 1336.)
- Tait, John, late of Hollywood Senior Citizens Village, 3 Williams Road, Nedlands, Retired Miner, died 18/2/81.
- Turner, Richard Newton, late of 43 Blythe Avenue, Mount Yokine, Storeman, died 22/10/80.
- Willoughby, Donald Edward, formerly 14A Bernard Street, Claremont, late of Sunset Hospital Beatrice Road, Dalkeith, Retired Fitter and Turner, died 31/1/81.

Dated at Perth this 1st day of April, 1981.

L. C. RICHARDSON,
General Manager.

WEST AUSTRALIAN TRUSTEES LIMITED
ACT 1893-1979.

NOTICE is hereby given that pursuant to section 4A of the West Australian Trustees Limited Act 1893-1979 West Australian Trustees Limited has elected to administer the estates of the undermentioned deceased persons:

- Name of the deceased; Occupation; Address; Date of Death; Date Election filed.
- Rankin, Alfred Leslie; Invalid pensioner; formerly of Wembley late of North Beach; 19/11/80; 1/4/81.
- Rendall, Gertrude Kathleen; Married Woman; late of Dianella; 25/12/80; 1/4/81.

Dated at Perth this 1st day of April, 1981.

L. C. RICHARDSON,
General Manager.

TRUSTEES ACT 1962.

Notice to Creditors and Claimants.

CREDITORS and other persons having claims (to which section 63 of the Trustees Act 1962 relates) in respect of the Estates of the undermentioned deceased persons, are required by Perpetual Trustees W.A. Ltd. of 95-99 St. George's Terrace, Perth, to send particulars of their claims to the Company, by the undermentioned date, after which date the said Company may convey or distribute the assets, having regard only to the claims of which the Company then has notice.

Claims for the following expire 8 May 1981:—

Ansell, Sidney, late of 6/27 Melling Court, Karawara, but formerly of 12 Elanora Road, Armadale, Caretaker. Died 6 February 1981.

Badham, George Richard, late of 6 Elizabeth Street, White Gum Valley, formerly of Beaconsfield, Storeman (formerly Store Manager). Died 10 December 1980.

Hogan, Dorothy May, late of 57 Moulden Avenue, Mount Yokine, Married Woman. Died 28 February 1981.

Jones, Kathleen, late of 14B Gull Street, Marmion, Widow. Died 16 February 1981.

Lowson, Robert James, late of 83 Grand Promenade, Bedford, Retired Dried Fruit Inspector. Died 22 January 1981.

Wilander, Laura May, late of 78 Tuckey Street, Mandurah, Widow. Died 15 January 1981.

Claims for the following expire 15 May 1981:—

Kelly, Grace Lillian, late of 9 Crossland Street, Carnarvon, Widow. Died 17 December 1980.

Paterson, John Alexander, late of 406 Turner Way, Karratha, Plant Operator. Died 18 January 1981.

Rafferty, Hugh Stanley, late of 5 Westmacott Street, Esperance, Retired Administrative Officer. Died 21 January 1981.

Dated at Perth this 31st day of March, 1981.

D. M. COCHRANE,
Assistant Secretary,
Perpetual Trustees W.A. Ltd.

PERPETUAL TRUSTEES W.A. LTD. ACT.
1922-1979.

NOTICE is hereby given that pursuant to section 4A(3) of the Perpetual Trustees W.A. Ltd. Act 1922-1979 the Company has elected to administer the estates of the undermentioned deceased persons.

Dated at Perth the 31st day of March, 1981.

D. M. COCHRANE,
Assistant Secretary,
Perpetual Trustees W.A. Ltd.

Name of Deceased; Occupation; Address; Date of Death; Date Election Filed.

Hogan, Dorothy May; Married Woman; Mt. Yokine; 28/2/81; 27/3/81.

Kelly, Grace Lillian; Widow; Carnarvon; 17/12/80; 16/3/81.

Ansell, Sidney; Caretaker; Karawara; 6/2/81; 27/3/81.

TRUSTEE ACT 1962.

Notice to Creditors and Claimants.

CREDITORS and other persons having claims (to which section 63 of the Trustee Act relates) in respect of the Estates of the undermentioned deceased persons are required to send particulars of their claims to me on or before the 4th day of May 1981 after which date I may convey or distribute the assets, having regard only to the claims of which I then have notice.

Cherry, Brenda Wynefred, late of Unit 1 Chester Court, 2 Chester Road, Claremont, spinster, died 14/3/81.

Chester, Lydia, formerly of 25 Cargill Street, Victoria Park, late of Mt. Henry Hospital, Cloister Avenue, Como, widow, died 31/10/71.

Easton, George William, formerly of 37 Cargill Street, Victoria Park, late of 35 France Street, Mandurah, retired MTT clerk, died 5/2/81.

Elston, Edna May, late of Lakeview Lodge, Britannia Road, Mt. Hawthorn, widow, died 12/3/81.

England, Maida Harriett, late of Extended Care Unit, Regional Hospital, Albany, widow, died 29/2/80.

Gilchrist, John Amos, late of 15 Elizabeth Street, Bayswater, retired bank messenger, died 7/3/81.

Glass, Elizabeth Winifred, late of Sunset Hospital, Beatrice Road, Dalkeith, widow, died 30/1/81.

Hardinge, Florence Mary, late of Flat 1, 131 Alexander Drive, Dianella, widow, died 11/3/81.

Johnson, Raymond Kent, late of Flat 1, 131 Alexander Maylands, retired shire clerk, died 9/3/81.

Moore, Frances Jean, late of Bunbury Nursing Home, Hayes Street, Bunbury, widow, died 17/2/81.

Orrell, Francis William, late of Unit 2, 125-127 Hastings Street, Scarborough, retired dry cleaner, died 11/2/81.

Potter, Florence Elizabeth, late of 592 Light Street, Dianella, widow, died 8/3/81.

Ransome, Phyllis Hannah, late of 36 Jones Street, Collie, married woman, died 6/3/81.

Renouf, Derek Arthur, late of 280 Geograph Bay Road, West Busselton, retired purchasing officer, died 15/3/81.

Taylor, Marion Dorothy, late of 31 Howes Crescent, Dianella, married woman, died 23/2/81.

Whitford, Alfred Hedley, late of 3 Dixon Road, Kalamunda, retired foreman, died 13/3/81.

P. W. McGINNITY,
Public Trustee,
565 Hay Street, Perth.

**FLORA OF
WESTERN AUSTRALIA
Vol. 1, Part 1 (only)
By C. A. Gardner.**

Prices—

Counter Sales—\$4.50
Mailed Country—\$6.50
Mailed Local—\$5.80
Mailed Interstate—\$7.60

SUBSCRIPTION CHARGES

GOVERNMENT GAZETTE

Counter Sales, per copy—\$0.60
Annual Subscription (Excluding
Extraordinary Copies) Including
Postage (Surface Mail)—\$67.00
per annum

INDUSTRIAL GAZETTE

Counter Sales—per copy—\$1.70
Annual Subscription, Including Postage
(Surface Mail)—\$35.00 per annum

HANSARD

Counter Sales, per copy—\$1.50
Annual Subscription, Including Postage
(Surface Mail)—\$40.00

**Report of Government Secondary
Schools Discipline Committee**

**DISCIPLINE IN
SECONDARY SCHOOLS
IN WESTERN AUSTRALIA
1972**

Prices—

Counter Sales—\$1.00
Mailed Local—\$2.30
Mailed Interstate—\$3.00
Mailed Country—\$4.10

— NOTICE —

**COMMITTEE OF INQUIRY
INTO
RATES AND TAXES
ATTACHED TO LAND VALUATION,
REPORT 1975**

(Mr. Gerald Keall, Chairman)

Prices—

Counter Sales—\$2.30
Mailed Local—\$3.30
Mailed Country—\$4.30
Mailed Interstate—\$5.40

**POST SECONDARY EDUCATION
IN
WESTERN AUSTRALIA
REPORT 1976**

Chairman—Professor P. H. Partridge

Prices—

Counter Sales—\$3.00
Mailed—
Mailed (W.A.)—\$3.80
Mailed Interstate—\$3.90

**RELIGIOUS EDUCATION IN THE
GOVERNMENT SCHOOLS OF
WESTERN AUSTRALIA JULY 1977**

Chairman Mr. W. E. Nott, S.M.

Prices—

Counter Sales—\$1.90
Mailed W.A.—\$2.80
Mailed Interstate—\$2.90

SUBSCRIPTION CHARGES**GOVERNMENT GAZETTE**

Counter Sales, per copy—\$0.60

Annual Subscription (Excluding
Extraordinary Copies) Including
Postage (Surface Mail)—\$67.00
per annum**INDUSTRIAL GAZETTE**

Counter Sales—per copy—\$1.70

Annual Subscription, Including Postage
(Surface Mail)—\$35.00 per annum**HANSARD**

Counter Sales, per copy—\$1.50

Annual Subscription, Including Postage
(Surface Mail)—\$40.00

**REPORT ON COMMITTEE OF
INQUIRY INTO RESIDENTIAL
CHILD CARE, SEPTEMBER, 1976**
CHAIRMAN—BERYL GRANT

Prices—

Counter Sales—\$2.50

Mailed Local—\$4.50

Mailed Country—\$4.70

Mailed Interstate—\$5.60

Available only from Harbour and Light
Department, 6 Short Street, Fremantle.
Phone 335 1211.—

Navigable Waters Regulations, 1958.

Regulations for Preventing Collisions at Sea.

Regulations for the Examination of Applicants
for Masters, Mates, Coxswain, Engineers,
Marine Motor Engine Drivers and Marine
Surveyors.

**REPORT OF THE ROYAL
COMMISSION "FREMANTLE
PRISON" 1973.**

(Commissioner, His Honour Robert E. Jones.)

Prices—

Counter Sales—\$1.50

Mailed Local—\$2.50

Mailed Country—\$3.50

Mailed Eastern States—\$4.60

**ELECTORAL ACT ENQUIRY
REPORT OF HIS HONOUR A. E. KAY
TO THE**

**HONOURABLE D. H. O'NEIL, M.L.A.
CHIEF SECRETARY**

Counter Sales—\$2.00

Mailed W.A.—\$2.80

Mailed Interstate—\$2.90

Loose and Bound Statutes

(\$14.50) 20.50 25.70
Sessional Bills—\$15.00 AUSTRALIA WIDE.

**PROPOSED
INDUSTRIAL RELATIONS ACT**

AS PREPARED BY**E. R. KELLY, ESQ.,**

Senior Commissioner

W.A. Industrial Commission

September 21, 1978.

Counter Sales—\$1.50.

Mailed W.A.—\$2.30

Mailed Interstate—\$2.40

**COMMISSION OF THE PEACE FOR
W.A.—JULY, 1980**

Prices—

Counter Sales—\$1.30

Mailed—Local \$2.10

Country and Interstate—\$2.20

**REPORT OF LAVERTON
ROYAL COMMISSION 1975-76**

Chairman Gresley D. Clarkson.

Prices—

Counter Sales—\$2.00

Mailed Local—\$3.00

Mailed Country—\$4.00

Mailed Interstate—\$5.10

**PRICE OF
SUBSCRIPTIONS FOR—**

Government Gazette—

Annual Subscription—\$67.00

Counter Sales, Single Copies—\$0.60

Hansard (Parliamentary Debates)—

Annual Subscription—\$40.00

Counter Sales, Single Copies—\$1.50

Western Australian Industrial Gazette—

Annual Subscription—\$35.00

Counter Sales, Single Copies—\$1.70

CURRENT RELEASE.

**REPORT BY COMMITTEE OF INQUIRY
INTO
TEACHER EDUCATION,
NOVEMBER, 1980.**

Chairman—Dr. R. L. VICKERY

Prices:—

Counter Sales—\$2.50.

Mailed Local—\$3.30.

Mailed Interstate—\$3.40.

**COMPANIES ACT No. 82, 1961-1975
(Fifth Reprint Approved 18/3/76)
Includes Amendment Act No. 100 of 1975.**

— NOW AVAILABLE —

Counter Sales—\$7.50

Mailed Local—\$8.80

Mailed Country—\$9.50

Mailed Interstate—\$10.60

SPECIAL NOTICE.

Concerning "Government Gazette" notices for publication lodged at the Government Printer's Wembley Office—notice must be lodged with "Parliamentary Papers" Salvado Road, Wembley prior to 3.00 p.m. on the Wednesday before publication.

WILLIAM C. BROWN, J.P.
Government Printer.

**REPORT OF THE HONORARY
ROYAL COMMISSION OF
INQUIRY INTO THE
CORRIDOR PLAN FOR PERTH
(Hon. F. R. White, M.L.C.
Chairman)**

Prices—

Counter Sales—\$2.00

Mailed W.A.—\$2.80

Mailed Interstate—\$2.90

**NOTICE TO GOVERNMENT
AUTHORITIES.**

The Government Printer has advised that the standard issue of 80 gsm paper for use in photocopying equipment is no longer available and a lighter grammage paper 75 gsm is obtainable from the Government Printing Office.

The new stationery is of superior quality and is designed to suit dry and liquid toner copiers. The 75 gsm stock is available at a reduced price.

N O T I C E**TRADING HOURS**

**WEMBLEY—HEAD OFFICE
(Parliamentary Papers)
GOVERNMENT PRINTER'S
PUBLICATION SALES OFFICE
SALVADO ROAD, WEMBLEY**

Phone 381 3111 Extensions 374 and 376
8.00 a.m. to 4.30 p.m.
(Continually Mon. to Fri.)

**PERTH OFFICE
GOVERNMENT PUBLICATIONS CENTRE
(Parliamentary Papers)
Ground Floor Superannuation Bldg.
32 St. George's Terrace, Perth 6000
Telephone 325 0231 Ext. 375
8.15 a.m. to 4.25 p.m.
(Continually Mon. to Fri.)**

**REPORT OF THE EGG INDUSTRY
ENQUIRY OF W.A., 1973.**

(Neil D. McDonald Enquirer.)

Prices—

Counter Sales—\$3.50

Mailed Local—\$5.50

Mailed Country—\$5.70

Mailed Interstate—\$6.60

ROTTNEST ISLAND IN HISTORY AND LEGEND

Its Discovery and Development
Natural Beauties,
Fauna and Flora.

By W. Somerville.

Prices—

Counter Sales \$3.50.
Mailed W.A.—\$4.30
Mailed Interstate—\$4.40

REPORT ON LAMB MARKETING IN WESTERN AUSTRALIA

by Consumer Protection Bureau,
5th July, 1974.

Prices—

Counter Sales—\$1.40
Mailed Local—\$2.70
Mailed Country—\$3.40
Mailed Interstate—\$4.50

LOCAL GOVERNMENT ACT, No. 84, 1960-1976

(Third Reprint approved 21/11/77) includes
Amendment Act No. 124 of 1976

— NOW AVAILABLE —

Counter Sales—\$4.50
Mailed Local—\$6.50
Mailed Country—\$6.70
Mailed Interstate—\$7.60

REPORT OF

THE SPECIAL COMMITTEE ON
THE PROPOSAL FOR A WEST-
ERN AUSTRALIAN HERITAGE
COMMISSION — 1975.

(Chairman—Mr. R. H. Doig)

PRICES—

Counter Sales—\$1.50
Mailed W.A.—\$2.30
Mailed Interstate—\$2.40

THE NATURAL FEATURES OF ROTTNEST ISLAND

Collated By G. R. W. Meadly M.Sc.

Prices—

Counter Sales—\$1.80
Mailed Australia Wide—\$2.30

NOTICE TO SUBSCRIBERS.

“GOVERNMENT GAZETTE” EASTER HOLIDAYS.

IT is hereby notified for public information that the
“Government Gazette” for Easter week will be
published on THURSDAY, 16 APRIL 1981, in lieu
of Good Friday.

All notices for publication must be in the hands of
the Government Printer before 3 p.m. on TUESDAY,
14 APRIL 1981.

WILLIAM C. BROWN,
Government Printer.

CONTENTS.

REGULATIONS, BY-LAWS, RULES, DETERMINATIONS, ORDERS.

	Page
Health Act—By-laws—City of Fremantle	1112

GENERAL CONTENTS.

	Page
Agricultural Products Act	1139
Agriculture, Department of	1139
Chief Secretary's Department	1112
Child Welfare Act	1116
Commissioners for Declarations	1112
Companies Act	1143-5
Companies (Co-operative) Act	1145
Crown Law Department	1112
Deceased Persons' Estates	1145-7
Finance Brokers Control Act	1111
Health Department	1112-3
Municipal Health By-laws	1112
Industrial Arbitration Act	1139
Justices of the Peace	1112
Lands Department	1116-8
Local Government Department	1111, 1130-8
Main Roads	1128, 1142
Medical Department	1113
Metropolitan Region Planning	1125-6
Metropolitan Water Supply, etc.	1129
Municipalities	1130-4
Notices of Intention to Resume Land	1128
Orders in Council	1111
Partnerships Dissolved	1145
Perpetual Trustees W.A. Ltd. Act	1146
Police Department	1113-6
Public Trustee	1146-7
Public Works Department	1126-8
Registrar General	1143
Sale of Unclaimed Found and Lost Property	1113-6
Tender Board	1140-2
Tenders Accepted	1128, 1141-2
Tenders for Government Printing	1143
Tenders Invited	1126-7, 1140-1
Town Planning	1118-25
Treasury	1111-2
Trustees Act	1145-7
West Australian Trustees Limited Act	1146