

[2941]

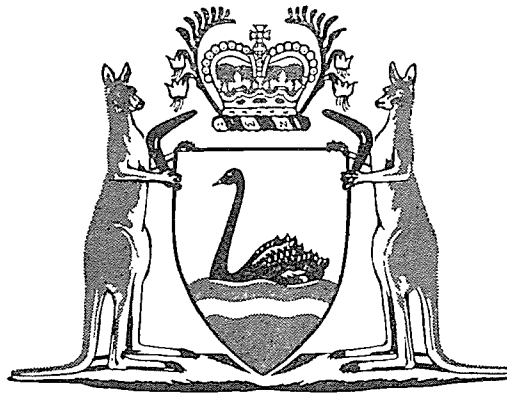

# Government Gazette

OF

WESTERN AUSTRALIA

(Published by Authority at 3.30 p.m.)

---

---

No. 58]

PERTH: MONDAY, 20 JULY

[1981

---

---

CONSTRUCTION SAFETY ACT 1972.

## CONSTRUCTION SAFETY REGULATIONS 1973

PUBLISHED in the *Government Gazette* on 28 November 1973. Reprinted pursuant to the Reprinting of Regulations Act 1954 incorporating the amendments published in the *Government Gazette* on—

14 November 1975;  
5 March 1976;  
15 October 1976;  
26 November 1976;  
3 August 1979; and  
8 June 1979.



Approved for Reprint 24 June 1981.

CONSTRUCTION SAFETY ACT 1972.

CONSTRUCTION SAFETY REGULATIONS 1973

ARRANGEMENT.

Regulation  
Number.

PART I.—PRELIMINARY.

1. Citation.
2. Arrangement.
3. Interpretation.

PART II.—GENERAL.

4. Inspectors' certificates.
5. Inspector not to interfere unreasonably.
6. Inspector to inspect.
7. Local authority to notify Chief Inspector.
8. Persons hiring out equipment to notify Chief Inspector.
9. Hire of defective equipment.
10. Testing authority.
11. General offence.

PART III.—NOTIFIABLE WORK AND FEES.

12. Interpretation.
13. Notifiable work.
14. Fees for notifiable work.
15. Fees recoverable as a debt.
16. Notice of notifiable work by main contractor or owner.
17. Notice by sub-contractor.

PART IV.—CONSTRUCTION OF SCAFFOLDING.

Division 1.—General.

18. General.

Division 2.—Metal Tube Construction.

19. Interpretation.
20. General standard of metal tubes.
21. Specifications of steel tubes.
22. Specifications of aluminium tubes.
23. Specifications of fittings.
24. Specifications of couplers.
25. Chief Inspector may demand proof of standard.
26. Arrangement of tubular scaffolding.
27. Loading of metal tube scaffolding.

Division 3.—Other Types of Metal Scaffolding.

28. Tubular mobile scaffolding.
29. Frame scaffolding.
30. Modular scaffolding.
31. Bird cage scaffolding.

Division 4.—Sawn Timber Scaffolding.

32. Specification of timber members.
33. Arrangement of sawn timber scaffolding.

Division 5.—Scaffolding on Circular Steel Structures and Tanks.

34. Specifications of scaffolding for circular steel structure.

Regulation  
Number.

## Division 6.—Boatswains' Chairs.

- 35. Interpretation.
- 36. Forbidden use.
- 37. Notice.
- 38. Design and erection.
- 39. Specifications.

## Division 7.—Light Duty Suspended Staging.

- 40. Interpretation.
- 41. Design and inspection.
- 42. Forbidden use.
- 43. Notice.
- 44. Specification of light duty suspended stage.
- 45. Outriggers.
- 46. Loading.

## Division 8.—Suspended Scaffolding.

- 47. Interpretation.
- 48. Design.
- 49. Inspection.
- 50. Specifications of suspended scaffolding.
- 51. Maximum loading of suspended scaffolding.

## Division 9.—Platforms and Edge Protection.

- 52. Specifications of working platform.
- 53. Specifications of platform planks.
- 54. Guard rails.
- 55. Fender boards.

## PART V.—HOISTING APPLIANCES.

## Division 1.—General

- 56. Interpretation.
- 57. Forbidden use.

## Division 2.—Cantilever Platform Hoists.

- 58. Design and inspection.
- 59. Specification for cantilever hoists.

## Division 3.—Tower Hoists and Skip Hoists.

- 60. Driver's qualifications.
- 61. Application for approval.
- 62. Inspection.
- 63. Testing before use.
- 64. Tower hoists and skip hoists.

## Division 4.—Miscellaneous Hoisting Appliances.

- 65. Slewing jib unit.
- 66. Pivoted jib arm.

## PART VI.—MISCELLANEOUS GEAR.

- 67. Ladders.
- 68. Splicing.
- 69. Safe working load of flexible steel wire.
- 70. Guards on power driven equipment.
- 71. Clamps.
- 72. Hooks.
- 73. Slings.
- 74. Appliances on scaffolding.

Regulation  
Number.

- 75. Use of drums.
- 76. Lift boxes.
- 77. Landing platforms.

#### PART VII.—GENERAL SAFETY.

##### Division 1.—Gantries, Hoardings and Barricades.

- 78. Interpretation.
- 79. Main contractor to provide public safety.
- 80. Gates not to open outwards.
- 81. Design and approval of gantries.
- 82. Minimum load capacity of a gantry.
- 83. Specifications of gantries.
- 84. Steel tubing gantries.
- 85. Fabricated steel gantries.
- 86. Timber gantries.
- 87. Protection to remain in position.

##### Division 2.—Miscellaneous Provisions.

- 87A. Risk to safety or health to be avoided.
- 88. Main contractor to provide safety.
- 89. Parts of scaffolding not to be removed.
- 90. Lifting persons by hoisting appliance.
- 91. Wires crossing roads.
- 92. Notification of supply authority.
- 93. Steel trench sheeting or piling.
- 94. Lifting and lowering material.

##### Division 3.—Electrical Work.

- 95. Interpretation.
- 96. Switchboards.
- 97. Connections.
- 98. Power driven equipment.

##### Division 4.—Protective Equipment and Health.

- 99. Safety helmets.
- 100. Footwear.
- 101. Work near water.
- 102. Safety belts.
- 103. Noise.
- 104. Eye protection.
- 105. Fumes and dust.
- 106. Blasting in public places.
- 107. Fire hazards.
- 108. Gases, liquids and vapours, etc.
- 109. General.

##### Division 5.—Welding and Cutting.

- 110. General.
- 111. Conditions of work and workplace.
- 112. Gas cylinders.
- 113. Electric welding.
- 114. Duty to supply protective equipment.

##### Division 6.—Construction, Alteration or Repair of Lifts.

- 115. Provision of power supply.
- 116. Entry by other persons.
- 117. Lighting and signalling.

Regulation  
Number.

- 118. Building in use.
- 119. Work in lift shafts.
- 120. Use of permanent cars as aids.
- 121. Use of permanent and false cars in same shaft.
- 122. Use of false cars as platforms.
- 123. Winches.

Division 7.—Formwork and Falsework.

- 124. Components used in formwork and falsework.
- 125. General erection of formwork.
- 126. Certified drawings.

Division 8.—Excavation Work and Trenching Work.

- 127. Excavations near buildings.
- 128. Hoisting appliances and equipment.
- 129. Safety conditions in excavation work.
- 130. Shoring of excavation work.
- 131. Shoring of trenches.
- 132. Specifications of shoring.

Division 9.—Demolition Work.

- 133. Safety precautions.
- 134. Cantilevered catch platforms.
- 135. Specifications of cantilevered catch platforms.
- 136. Scaffolding in demolition work.
- 137. Scaffolding to be maintained in position.
- 138. Precautions in demolition work.
- 139. Demolition work to be as prescribed.
- 140. Removal of debris.
- 141. Use of appliances.
- 142. Unstable structures.
- 143. Chimney stacks.

PART VIII.—ROOFS SHEATHED WITH ASBESTOS CEMENT SHEETS  
OR WITH BRITTLE ROOF MATERIALS.

- 144. Interpretation.
- 145. Distance between supports.
- 146. Asbestos roofs.
- 147. Specification of safety mesh.
- 148. Fixing of safety mesh.
- 149. Asbestos box-gutters.
- 150. Roofs of brittle roof materials.
- 151. Inspection.

PART IX.—EXPLOSIVE POWERED TOOLS.

Division 1.—General.

- 152. Interpretation.
- 153. Explosive powered tool operators to use tools.
- 154. General requirements of tools and projectiles.
- 155. Applications for approval.
- 156. Forbidden manufacture and use of projectiles.
- 157. Strength of charges to be indicated.
- 158. Registration of tools.
- 159. Inspection.
- 160. Repair.
- 161. Protective devices.

Regulation  
Number.

Division 2.—Use of Tools.

- 162. Notice.
- 163. Forbidden equipment.
- 164. Incorrect fitting of equipment.
- 165. Compliance with maker's instructions.
- 166. Barrel extensions.
- 167. Forbidden use of charges.
- 168. Use of tools in dangerous atmosphere.
- 169. Handling tools.
- 170. Discharging tools.
- 171. Free fire prohibited.
- 172. Forbidden firing.
- 173. Removal of foreign matter.
- 174. Procedure on mechanical failure of tool.

Division 3.—Care and Storage of Tools and Explosive Charges.

- 175. Storage of tools.
- 176. Storage of charges.

PART X.—USE, STORAGE AND CONVEYANCE OF EXPLOSIVES ON A SITE.

- 177. Interpretation.
- 178. Only authorized explosives to be used.
- 179. Shotfirer's permit.
- 180. Storage and conveyance of explosives.
- 181. Carrying of explosives.

PART XI.—COMPRESSED AIR AND DIVING WORK.

- 182. Interpretation.
- 183. Diver to be medically fit.
- 184. Qualifications of divers.
- 185. Qualifications of diving supervisor.
- 186. Qualifications of diver's attendant.
- 187. Duties at diving.
- 188. Limitation on deep or hazardous diving.
- 189. Limitation on diving.
- 190. Forbidden work.
- 191. Purity of breathing medium.
- 192. Decompression chamber.
- 193. Forbidden diving times.
- 194. Specification of underwater breathing apparatus.
- 195. Log book.

PART XII.—EXAMINATION FOR CERTIFICATES, LICENCES AND PERMITS.

- 196. Interpretation.
- 197. Certificate for Inspection of Construction Safety.
- 198. Application for and issue of certificates.
- 199. Certificate of competency as crane chaser or dogman.
- 200. Certificate of competency as rigger.
- 201. Certificate of competency as scaffolder.
- 202. Crane chaser or dogman to hold certificate
- 203. Workman to hold rigging permit.
- 204. Scaffolder to carry out scaffolding.
- 205. Explosive powered tool operator.
- 206. Provisional certificates.
- 207. Restricted certificates of competency.

PART XIII.—FORMS.

- 208. Forms.
- APPENDIX A1.
- APPENDIX A2.
- APPENDIX A3.
- APPENDIX B1.
- APPENDIX B2.
- APPENDIX B3.
- APPENDIX B4.
- SCHEDULE.
- INDEX.



Reprinted pursuant to the Reprinting of Regulations Act 1954, by authority of the Attorney General dated 24 June 1981.

CONSTRUCTION SAFETY ACT 1972.

**CONSTRUCTION SAFETY REGULATIONS 1973**

PART I.—PRELIMINARY.

1. These regulations may be cited as the Construction Safety Regulations 1973.<sup>1</sup> Citation.

2. These regulations are divided into Parts as follows—

PART I.—PRELIMINARY, regulations 1-3.

PART II.—GENERAL, regulations 4-11.

PART III.—NOTIFIABLE WORK AND FEES, regulations 12-17.

PART IV.—CONSTRUCTION OF SCAFFOLDING—

Division 1.—General, regulation 18.

Division 2.—Metal Tube Construction, regulations 19-27.

Division 3.—Other Types of Metal Scaffolding, regulations 28-31.

Division 4.—Sawn Timber Scaffolding, regulations 32-33.

Division 5.—Scaffolding on Circular Steel Structures and Tanks, regulation 34.

Division 6.—Boatswains' Chairs, regulations 35-39.

Division 7.—Light Duty Suspended Stage, regulations 40-46.

Division 8.—Suspended Scaffolding, regulations 47-51.

Division 9.—Platforms and Edge Protection, regulations 52-55.

PART V.—HOISTING APPLIANCES—

Division 1.—General, regulations 56-57.

Division 2.—Cantilever Platform Hoists, regulations 58-59.

Division 3.—Tower Hoists and Skip Hoists, regulations 60-64.

Division 4.—Miscellaneous Hoisting Appliances, regulations 65-66.

PART VI.—MISCELLANEOUS GEAR, regulations 67-77.

PART VII.—GENERAL SAFETY—

Division 1.—Gantries, Hoardings and Barricades, regulations 78-87.

Division 2.—Miscellaneous Provisions, regulations 87A-94.

Division 3.—Electrical Work, regulations 95-98.

Division 4.—Protective Equipment and Health, regulations 99-109.

Division 5.—Welding and Cutting, regulations 110-114.

Division 6.—Construction, Alteration and Repair of Lifts, regulations 115-123.

Division 7.—Formwork and Falsework, regulations 124-126.

Division 8.—Excavation Work and Trenching Work, regulations 127-132.

Division 9.—Demolition Work, regulations 133-143.

PART VIII.—ROOFS SHEATHED WITH ASBESTOS CEMENT SHEETS OR WITH BRITTLE ROOF MATERIALS, regulations 144-151.

PART IX.—EXPLOSIVE POWERED TOOLS—

Division 1.—General, regulations 152-161.

Division 2.—Use of Tools, regulations 162-174.

Division 3.—Care and Storage of Tools and Explosive Charges, regulations 175-176.

Arrange-  
ment.  
Amended by  
G.G. 5/3/76,  
p. 689.

<sup>1</sup> Came into operation on 8 February 1974.

SCHEDULE—*continued.*

PART X.—USE, STORAGE AND CONVEYANCE OF EXPLOSIVES ON A SITE, regulations 177-181.

PART XI.—COMPRESSED AIR AND DIVING WORK, regulations 182-195.

PART XII.—EXAMINATIONS FOR CERTIFICATES, LICENCES AND PERMITS, regulations 196-207.

PART XIII.—FORMS, regulation 208.

Interpretation.

3. (1) In these regulations, unless the context otherwise requires—

“approval” means of the Chief Inspector;

“approved” means by the Chief Inspector;

“A.S.” means Australian Standard;

“B.S.” means British Standard;

“Form” means a form in the Schedule;

“height”—

(a) in relation to a building or structure or intended building or structure, means the measurement that is obtained by a vertical measurement of the distance between the highest point of the building or structure or intended building or structure and the surface of the site;

(b) in relation to a point at which a workman is supported or intended to be supported on scaffolding, means the distance between that point and the surface on which the scaffolding stands;

“public place” includes a street, way and place which the public are allowed to use, whether the street, way or place is or is not on private property;

“regulation” means one of these regulations;

“S.A.A.” means the Standards Association of Australia;

“Schedule” means the Schedule to these regulations;

“supply authority” means any person supplying water, gas or electricity under the authority of any statute;

“the Act” means the Construction Safety Act 1972.

(2) In these regulations, unless the context otherwise requires, technical terms not otherwise defined have the respective meanings ordinarily ascribed to them by the building industry.

## PART II.—GENERAL.

Inspectors' certificates. (Form 1.)

4. A certificate of the appointment of a person as an inspector shall be in the form of Form 1.

Inspector not to interfere unreasonably.

5. Without limiting the provisions of regulation 6 it is the duty of every inspector appointed for the purposes of the Act so to exercise and discharge his powers and duties as not to interfere unreasonably or unduly with any work or process being carried out on any scaffold, or in connection with, any scaffolding or gear.

Inspector to inspect.

6. (1) An inspector shall examine all scaffolding and gear used in connection with that scaffolding once in every three months during the period that it is erected or is in use.

(2) Where an inspector is of opinion that any scaffolding, hoisting appliance or gear or any part of any scaffolding, hoisting appliance or gear is unsafe for use he shall mark it as unsafe for use and a person shall not use any scaffolding, hoisting appliance or gear that is so marked until it has been made good to the satisfaction of an inspector.

(3) A person shall not remove or obliterate any marking made by an inspector under subregulation (2) of this regulation.

(4) Where an inspector is of opinion that any scaffolding, hoisting appliance, gear, power driven equipment, explosive powered tool, formwork or equipment used in connection with compressed air work on a site is not of a satisfactory standard of safety he may require the main contractor or owner to alter any one or more of those things in such a manner as he thinks is necessary to attain that standard of safety.

7. (1) The clerk of a local authority shall within the first week of each month notify the Chief Inspector of all permits issued by the local authority in relation to the commencement of construction work in the local authority. Local authority to notify Chief Inspector

(2) The notification required under subregulation (1) of this regulation shall be in the form of Form 2. (Form 2.)

8. Every person or firm carrying on the business of hiring any scaffolding or gear that is the subject of these regulations shall within twenty-four hours after the delivery to a hirer of any scaffolding or gear on hire, notify the Chief Inspector of the hiring, setting out in the notice, with respect to the scaffolding or gear— Persons hiring out equipment to notify Chief Inspector.

- (a) the date of its delivery;
- (b) the name of the hirer;
- (c) the address of the site where it is intended to be erected or used;
- (d) its type; and
- (e) by whom it is to be erected.

9. A person carrying on the business of hiring or erecting scaffolding, hoisting appliances, gear, formwork, power driven equipment or compressed air equipment shall not hire or erect for any work to which the Act applies any scaffolding, hoisting appliance, formwork, power driven equipment or compressed air equipment— Hire of defective equipment.

- (a) that does not comply with these regulations; or
- (b) that is defective or unsafe.

10. A person who applies for the approval of any scaffolding, hoisting appliance, gear, formwork, power driven equipment or compressed air equipment shall— Testing authority.

- (a) where a test is required, arrange for the test with an approved authority;
- (b) submit the relevant designs and specifications to the Chief Inspector;
- (c) pay the costs of the test; and
- (d) notify the Chief Inspector at least twenty-four hours in advance of the time of the test.

11. Where any matter or thing is by these regulations required, or forbidden to be done, or where, pursuant to authority given by these regulations, a person directs any matter or thing to be done, and the matter or thing required or directed to be done is not done, or the matter or thing forbidden to be done is done, then, every person offending against the direction or prohibition commits an offence against these regulations and is liable to a fine not exceeding four hundred dollars. General offence. Amended by G.G. 3/8/79, p. 2216.

### PART III.—NOTIFIABLE WORK AND FEES.

12. In this Part—

“ship yard” means a construction site that is used for building ships or boats and is required to be registered as a factory under the Factories and Shops Act 1963; Interpretation. Amended by G.G. 26/11/76, p. 4817.

“single storey dwelling” means a building or structure that—

- (a) has only one storey;
- (b) is used or is intended to be used exclusively as a self-contained private dwelling;

“two storey dwelling” means a building that—

- (a) has only two storeys;
- (b) is used or intended to be used exclusively as a self-contained private dwelling; and
- (c) is not connected or joined to any other building or structure.

Notifiable work.  
Amended by  
G.G. 5/3/76,  
p. 689;  
G.G. 26/11/76,  
p. 4817.

13. (1) In this regulation—

“other work” means the addition to, alteration, repair, maintenance, cleaning, painting, renewal, removal or dismantling of a building or structure.

(2) For the purposes of section 16 of the Act the following work is notifiable work—

- (a) construction of a building or structure other than a ship;
- (b) demolition of a non-residential building or structure;
- (c) demolition of a residential building of more than one storey;
- (d) other work carried out on a platform at a height exceeding 3 m or in a confined space, on a building or structure other than a ship or other floating structure;
- (e) driving or extracting piles, sheet piles and trench sheet;
- (f) [*deleted by G.G. 26/11/76, p. 4817.*]
- (g) sinking or lining of a well other than a well on land that is used principally for farming or residential purposes;
- (h) excavation work that exceeds a depth of 1.5 m and that has sides that exceed a slope greater than 1 m horizontal to 2 m vertical;
- (i) compressed air work;
- (j) work in which explosives are used;
- (k) construction, in a shipyard, of a ship or other floating structure that exceeds a length of 12 m.

Fees for notifiable work.  
Amended by  
G.G. 26/11/76,  
pp. 4817-8;  
G.G. 8/6/79,  
p. 1528.

14. (1) Subject to this regulation, the fees to be paid by a main contractor or owner who intends to commence notifiable work are as set out in the table below—

TABLE.

Notifiable Work.	Fee.
(a) Construction of, or additions to, a single or two storey dwelling where the value of the contract exceeds \$6 000.	\$10.00.
(b) Work that consists of— (i) window cleaning; (ii) sign maintenance or repairs; (iii) other minor maintenance, on a building or structure.	\$10 in respect of all such work commenced on that building or structure during the period of twelve months beginning on the 1st day of July in any year.
(c) Construction in a shipyard of ships or other floating structures that exceed a length of 12 m.	\$10 in respect of all such work commenced in that shipyard during the period of twelve months beginning on the 1st day of July in any year.
(d) Other construction or excavation work where the value of the contract— (i) does not exceed \$1 million; (ii) exceeds \$1 million.	15c for each \$100 or part thereof. \$1 500 plus \$1 for each \$1 000 or part thereof in excess of \$1 million.

(2) For the purpose of calculating the fees for a notifiable work—

- (a) where a contract includes separate works in different localities the work in each locality is a separate contract;
- (b) where a contract consists of separate stages of work to be carried out as part of a complete contract each stage is a separate contract;
- (c) where a contract relates to a single storey building that consists of more than one self contained private dwelling used or intended to be used as separate occupancies, each of the self-contained dwellings shall be regarded as a separate single storey dwelling;

(d) where a contract relates to a two storey building that consists of more than one self-contained private dwelling the fees shall be calculated at the rate prescribed in item (d) in the Table to subregulation (1) of this regulation.

(3) A main contractor or owner shall supply any information required by the Chief Inspector for the purpose of calculating the fees to be paid by him under subregulation (1) of this regulation.

(4) Where a dispute arises as to the value of the work under subregulations (1) or (2) of this regulation the main contractor or owner or the Chief Inspector may refer the dispute to the Minister whose decision is final.

(5) Where the notifiable work is carried out on a place that is used or is to be used—

(a) for public worship; or

(b) for a charitable purpose,

the Chief Inspector on being satisfied of that fact may remit to the owner half the fee paid in respect of that notifiable work.

(6) A person who objects to the decision of the Chief Inspector given under subregulation (5) of this regulation may appeal to the Minister whose decision is final.

15. All fees payable under regulation 14 constitute a debt and are recoverable in a court of competent jurisdiction.

Fees recoverable as a debt.

16. (1) The notice to be sent to the Chief Inspector under section 16 of the Act by a main contractor or owner is—

Notice of notifiable work by main contractor or owner. (Form 3 or Form 4.)

(a) in the case of notifiable work within paragraphs (b) and (c) of subregulation (1) of regulation 14, in the form of Form 3;

(b) in the case of any other notifiable work, in the form of Form 4.

(2) The notification given under subregulation (1) of this regulation shall be accompanied by the fee set out in relation to the work in regulation 14.

(3) A main contractor or sub-contractor who undertakes any part of any notifiable work shall comply with subregulation (1) of regulation 92.

17. A sub-contractor who undertakes any notifiable work shall not commence such work unless he has given notice to the Chief Inspector in the form of Form 3 or Form 4 and has paid the fee in relation to that work in regulation 14, but this regulation does not apply to a sub-contractor in relation to whose work the main contractor or owner has already complied with regulation 16 of these regulations.

Notice by sub-contractor. (Form 4.)

#### PART IV.—CONSTRUCTION OF SCAFFOLDING.

##### Division 1.—General.

18. A person shall not use any scaffolding in work to which the Act applies unless the scaffolding is of a type that is—

General

(a) prescribed by these regulations; or

(b) approved in writing.

##### Division 2.—Metal Tube Construction.

19. In this Division—

Interpretation.

“base plate” means a mild steel plate with an area of at least 0.0225 m<sup>2</sup> x 6 mm thick;

“bay” means the rectangular space enclosed by four adjacent standards for the full height of the scaffold or the equivalent space when applied to a putlog scaffold;

“brace” means a tube incorporated diagonally across two members in a scaffold and fixed to them to afford stability;

“heavy duty scaffold” means a scaffold that is normally erected for use by bricklayers, stonemasons or similar trades;

“independent scaffold” means a scaffold consisting of two rows of standards connected together longitudinally with ledgers and braces and transversely with transoms and putlogs;

“ledger” means a tube fixed horizontally to the standards to tie the scaffold longitudinally which may support the putlogs;

- “lift” means the height from the ground or floor to the lowest ledger, or the vertical distance between ledgers;
- “light duty scaffold” means a scaffold that is normally erected for use by electricians, painters, sign writers or general light duty maintenance workers;
- “medium duty scaffold” means a scaffold that is normally erected for use by carpenters, plasterers, glaziers or similar trades;
- “panel” means an area bounded by two longitudinally adjacent standards that is one lift in height;
- “putlog” means a member fixed horizontally across ledgers or across a ledger to an adjacent wall to support a working platform;
- “putlog scaffold” means a scaffold consisting of a single row of standards connected together longitudinally by ledgers and braces, with putlogs having one end fixed to the ledgers and the other end built into or resting on the wall of the building or structure;
- “sole plate” means a timber member of not less than the cross sectional dimensions prescribed for platform planks and of a length adequate to distribute the load;
- “span” means the distance measured along a member, between the centre lines of adjacent supports of that member;
- “standard” means a vertical supporting member;
- “tie” means a member used to secure the scaffold to a structure;
- “transom” means a transverse horizontal member, clamped to the standards or ledgers by right angle couplers.

General  
standard of  
metal tubes.

20. Metal tubes shall not be used in scaffolding unless they—
- (a) are straight and free from indentations, corrosion or other defect;
  - (b) have their ends cut clean and square with their axes; and
  - (c) are free from burrs and bevels.

Specifications  
of steel tubes.  
Amended by  
G.G. 5/3/76,  
p. 689.

21. Steel tubes shall not be used in scaffolding unless they—
- (a) are manufactured by the Continuous Weld Process (C.W.) method of manufacture and comply with the requirements for Grade 200 of A.S. 1450-1974, “Carbon Steel Tubes—Circular and non-Circular—For Mechanical and General Engineering Purposes”, except identification Clause 0.15;
  - (b) are round pipes of not less than 48.3 mm outside diameter, having a wall thickness of not less than 4 mm; and
  - (c) have permissible dimension tolerances of—
    - (i) outside diameter plus 0.4 mm minus 0.8 mm; and
    - (ii) wall thickness plus 15% and minus 10%.

Specifications  
of aluminium  
tubes.

22. Aluminium tubes shall not be used in scaffolding unless they—
- (a) are of extruded aluminium, conforming to Specification A.S.H50—1971, “Wrought Aluminium and Aluminium Alloy Extruded Tubes and Hollow Sections—For General Engineering Purposes”, having a tensile strength of not less than 262.5 M Pa, with an 0.2% proof stress of not less than 241.5 M Pa; the elongation measured on a gauge length of 50 mm shall be not less than 8%;
  - (b) are round pipes of not less than 48.3 mm outside diameter, having a wall thickness of not less than 4.5 mm; and
  - (c) have permissible dimension tolerances of—
    - (i) outside diameter, plus or minus 0.31 mm; and
    - (ii) wall thickness, plus or minus 0.23 mm.

Specifications  
of fittings.  
Amended by  
G.G. 5/3/76,  
p. 689.

23. A fitting or device shall not be used in scaffolding unless it—
- (a) is of a type that is approved in writing; and
  - (b) satisfies the testing methods of A.S. 1575-1974.

Specifications  
of couplers.

24. A coupler shall not be used in scaffolding unless it—
- (a) has no threaded blind holes;
  - (b) is designed or constructed so that when assembled, but before tightening, a part is not detached by any inadvertent action;

- (c) has a tightening bolt of not less than 12 mm in diameter with a hexagonal nut;
- (d) has a washer not less than 1.5 mm thick fitted beneath;
- (e) is provided with a rib or recess not less than 1.5 mm in height to prevent the bolt and washer from being displaced from the coupler, except where the geometry of the fitting positively holds the bolt in position;
- (f) where a hinge is provided, has a hinge pin not less than 8 mm in diameter;
- (g) is not less than 4 mm in any section of the body or flap;
- (h) accurately embraces over the whole area of its bearing surfaces the member or members on which it is used.
25. A main contractor or sub-contractor shall on request made by the Chief Inspector supply him with the manufacturer's specification of quality in respect of any gear. Chief Inspector may demand proof of standard.
26. (1) Tubular scaffolding shall consist of— Arrangement of tubular scaffolding.
- (a) a number of standards fixed by transoms and ledgers;
- (b) ledgers supporting putlogs or transoms; and
- (c) platform planks laid on putlogs or on transoms, with the whole arrangement braced and tied to form a rigid and stable structure.
- (2) The height of tubular scaffolding shall not exceed 45 m unless provision is made to relieve the weight of the scaffold by spurring or by other approved means. Maximum height.
- (3) Tubular scaffolding shall have standards that are— Standards.
- (a) spaced not more than—
- (i) 1.8 m apart for heavy duty scaffolds;
- (ii) 2.4 m apart for medium duty scaffolds; or
- (iii) 3 m apart for light duty scaffolds;
- (b) erected so that their joints do not occur—
- (i) in adjacent standards in the same lifts;
- (ii) in the same standard in adjacent vertical lifts; or
- (iii) more than once between any two adjacent ledgers;
- (c) founded on base plates and where necessary on sole plates or on an equivalent base construction;
- (d) straight throughout and set up in a vertical plane; and
- (e) where necessary, provided with suitable guards or fenders to prevent damage from any source.
- (4) Tubular scaffolding shall have ledgers that are— Ledgers.
- (a) clamped to the standards with right angle couplers;
- (b) spaced not more than 2 m apart on a standard;
- (c) erected so that their joints do not occur—
- (i) in vertically adjacent ledgers in the same bay;
- (ii) in the same ledger in adjacent bays;
- (d) continuous throughout the whole length of the scaffolding, except where access is provided; and
- (e) fixed in a horizontal plane.
- (5) Tubular scaffolding shall have putlogs that are— Putlogs.
- (a) set horizontally above each ledger;
- (b) fixed to each ledger either by right angle couplers or by putlog clips;
- (c) placed so that—
- (i) they are not more than 230 mm from a standard; and
- (ii) there is one on each side of every standard;
- (d) in single lengths;

- (e) subject to regulation 31, placed so that spans do not exceed 1.5 m;
  - (f) in position until that portion of the scaffolding is dismantled, but a transom may be substituted for two putlogs on each side of a standard.
- (6) Where a detachable blade fitting is used to support the putlog on a wall the detachable blade fitting—
- (a) shall be placed with the blade in a horizontal plane;
  - (b) shall be fixed beneath the putlog; and
  - (c) shall bear not less than 75 mm on the wall.
- Ties.
- (7) Tubular scaffolding shall have ties that are—
- (a) attached by right angle couplers—
    - (i) in the case of putlog scaffolding, to the standard or ledger; or
    - (ii) in the case of independent scaffolding, to the outside and inside standards or ledgers,
 and in each case as close as possible to the junction of the standards and ledgers;
  - (b) located no further than one bay from the ends of the scaffolding and in every third bay but this spacing may be increased to every sixth bay if—
    - (i) a system of horizontal diagonal plan bracing is added between the ties on the underside of the ledgers at the level that the ties occur; and
    - (ii) any joints in the span of the ledgers forming part of the horizontal diagonal plan bracing are positively secured by means of a splice tube and two swivel couplers; and
  - (c) located in the first lift of the scaffolding and at vertical intervals not exceeding 4 m.
- Bracing.
- (8) Tubular scaffolding shall be braced to form a rigid and stable structure by means of—
- (a) face braces that are attached to the external row of standards of the scaffolding and extend to the full length and height of the scaffolding; and
  - (b) transverse braces that are attached diagonally in every lift joining the internal and external standards—
    - (i) at both ends of the scaffolding; and
    - (ii) at intervals not exceeding 25 m.
- Loading of metal tube scaffolding.
27. Tubular scaffolding shall not be used to carry more than two working platforms across the full length of the scaffolding though shorter working platforms may be carried in different positions on the frame if the total load of the shorter working platforms does not exceed the total load of two fully loaded platforms, but in any event the total load on a platform in a bay shall not exceed—
- (a) 625 kg in the case of a heavy duty scaffold;
  - (b) 430 kg in the case of a medium duty scaffold; or
  - (c) 180 kg in the case of a light duty scaffold.
- Division 3.—Other Types of Metal Scaffolding.
- Tubular mobile scaffolding.
28. (1) A tubular mobile scaffold shall be arranged to consist of—
- (a) a number of standards fixed by transoms and ledgers;
  - (b) platform planks laid on putlogs or transoms;
  - (c) horizontal diagonal braces and ledgers fixed as near as practicable to the base of the standards; and
  - (d) castors fixed into the base of each standard,
- with the whole arrangement braced and tied to form a rigid and stable structure.
- (2) A castor shall not be used in a tubular mobile scaffold unless it—
- (a) has an effective locking device to prevent movement when the scaffold is in use;
  - (b) has a minimum diameter of 125 mm;
  - (c) has a shank or socket not less than 150 mm long and an eccentricity between the centre of the castor and the centre of the shank or socket not exceeding 60 mm.
  - (d) is properly secured in the standard by an approved method;



- (e) is not fitted with a pneumatic tyre; and  
 (f) has the safe working load clearly stamped on it.
- (3) A tubular mobile scaffold shall have a working platform—  
 (a) at a height not exceeding three times the least width between the castors;  
 (b) that is closely planked, except where access is provided;  
 (c) that extends not more than 250 mm nor less than 150 mm beyond the plan area unless a method is provided for plank location.
- (4) A working platform shall not be placed between separate mobile tubular scaffolds unless the mobile scaffolds are securely joined together by ledgers.
- (5) (a) A tubular mobile scaffold shall conform to the requirements of the table to this subregulation.  
 (b) A person shall not load a tubular mobile scaffold in excess of the weight prescribed in the table to this subregulation.

TABLE.

Class of Scaffold	Maximum Spacing of Standards	Span of Transom or Putlog	Maximum Load
Heavy Duty ....	1.8 m	1.5 m	625 kg
Medium Duty ....	2.4 m	1.8 m	430 kg
Light Duty ....	3 m	2.1 m	180 kg

29. (1) In this regulation—  
 “frame” means a fabricated unit consisting of standards, transoms and braces that are welded together to form a rigid and complete unit; and  
 “frame scaffolding” means a system of scaffolding using frames.
- (2) A person shall not use a frame in scaffolding unless the frame is of a type that has been approved in writing.
- (3) A frame scaffolding shall not be used unless—  
 (a) it is erected in accordance with the conditions of approval; and  
 (b) it is tied to the building or structure in accordance with subregulation (7) of regulation 26.
- (4) A frame scaffolding shall consist of frames that are—  
 (a) tied together by a continuous ledger that—  
 (i) is fixed to the external standard of each frame; and  
 (ii) is spaced at vertical intervals not exceeding 15 m;  
 (b) spaced either not more than 2 m apart in the case of heavy duty scaffolding or not more than 2.4 m apart in the case of light duty scaffolding;  
 (c) provided with adjustable base plates where the ground or surface is not level;  
 (d) braced in each panel on both the internal and external faces of the scaffolding.
- (5) A frame scaffolding shall be loaded and used in accordance with regulation 27.
30. (1) In this regulation—  
 “modular members” means standards, ledgers, transoms, putlogs and braces made of metal that are capable of being assembled into scaffolding of pre-determined shapes; and  
 “modular scaffolding” means a system of scaffolding using modular members.

Frame scaffolding.

Modular scaffolding.

(2) A person shall not use a modular member in scaffolding unless it is of a type that has been approved in writing.

(3) A modular scaffolding shall not be used unless—

- (a) it is erected in accordance with the conditions of approval; and
- (b) it is tied to the building or structure in accordance with subregulation (7) of regulation 26.

(4) A modular scaffolding shall not be used unless it is—

- (a) provided with adjustable base plates where the ground or surface is not level;
- (b) planked with planks designed for that modular system; and
- (c) braced in accordance with the approval.

(5) A modular scaffolding shall be loaded and used in accordance with regulation 27.

Bird cage scaffolding.

31. (1) In this regulation—

“bird cage scaffolding” means a scaffolding used for access to ceilings, soffits and walls.

(2) A bird cage scaffolding shall consist of—

- (a) standards;
  - (b) ledgers and transoms fixed on standards;
  - (c) putlogs fixed to ledgers on each side and within 230 mm of the standards, unless substituted by a single transom fixed to the ledger;
  - (d) a working platform at the required height,
- with the whole arrangement braced to form a rigid and stable structure.

(3) (a) A bird cage scaffolding shall conform to the requirement of the table to this subregulation.

(b) A person shall not load a bird cage scaffold in excess of the weight prescribed in the table to this subregulation.

TABLE.

Class of Scaffold	Maximum Longitudinal Spacing	Maximum Transverse Spacing	Maximum Load
Heavy Duty ....	1.8 m	1.5 m	625 kg
Medium Duty ....	2.4 m	1.8 m	430 kg
Light Duty ....	3 m	2.1 m	180 kg

Division 4.—Sawn Timber Scaffolding.

Specification of timber members.

32. (1) Timber shall not be used in a sawn timber scaffolding unless the timber is of standard grade hardwood or other approved timber.

(2) Sawn timber members shall not be used in scaffolding unless—

- (a) the standards have—
  - (i) where the scaffolding does not exceed a height of 4 m, a minimum dimension of 100 mm by 50 mm; or
  - (ii) where the scaffolding exceeds 4 m, such dimensions as may be approved by an inspector;
- (b) the ledgers have a minimum dimension of 100 mm by 50 mm; and
- (c) the putlogs have—
  - (i) where the span does not exceed 1.5 m, a minimum dimension of 100 mm by 75 mm; or
  - (ii) where the span exceeds 1.5 m, such dimensions as may be approved by an inspector.

33. (1) The arrangement of sawn timber scaffolding shall comply with subregulation (1) of regulation 26. Arrangement of sawn timber scaffolding.

(2) A sawn timber scaffolding shall have—

(a) standards that—

- (i) are spaced at distances not exceeding 2 m;
- (ii) are embedded in the ground to a depth of 300 mm unless an inspector directs otherwise;
- (iii) stand on a sole plate that satisfies an inspector;
- (iv) if made up of more than one length of timber, are doubled from the ground level, lapped and properly bolted together to the satisfaction of an inspector;

(b) ledgers that—

- (i) are securely bolted to standards with bolts that have a minimum diameter of 12 mm and are provided with washers; and
- (ii) commence at a distance not exceeding 2 m from the ground and are spaced at vertical intervals not exceeding 2 m, unless other distances are approved by an inspector; and

(c) putlogs that—

- (i) bear at least 100 mm on a wall or are supported on a wall by a mild steel plate—
  - (A) that extends 100 mm from the end of the putlog;
  - (B) that measures 50 mm wide and 6 mm thick; and
  - (C) that is bolted to the putlog with bolts with a diameter of not less than 8 mm; and
- (ii) are fixed to ledgers at distances not exceeding 2 m.

(3) Every bolt in a sawn timber scaffolding—

- (a) shall have a washer; and
- (b) shall be kept properly tightened as long as the scaffolding stands.

(4) Sawn timber scaffolding shall not be used to carry more than one working platform and the load carried on the platform shall not exceed 625 kg.

#### Division 5.—Scaffolding on Circular Steel Structures and Tanks.

34. (1) A person shall not use or construct, for any work in or in connection with a steel tank or circular steel structure, a scaffolding that is supported by the steel tank or structure, unless— Specifications of scaffolding for circular steel structure.

(a) lugs or saddle pieces of mild steel are welded to the surface of the tank to receive the hooks of the scaffolding platform;

(b) the scaffolding platform is supported from the lugs or saddle pieces or mild steel by brackets—

- (i) that are made of mild steel angle not less than 44 mm x 44 mm x 5 mm or mild steel tube of equivalent strength and rigidity and that are spaced with centres not exceeding 2.5 m apart on the tank face;
- (ii) that incorporate hooks formed by 50 mm x 6 mm mild steel that attach to the lugs; and
- (iii) that have an upstand with welded attachments to accommodate two guard rails or lifelines; and

(c) the working platform—

- (i) has platform planks that conform to regulation 53; and
- (ii) is fitted with a rigid guard rail 1 m above the working platform and a mid rail, or, where lifelines are used instead of rigid guard rails, the lifelines are not less than 16 mm in diameter cordage rope and are secured at each upstand with a maximum allowable sag of 50 mm.

(2) The workman who welds the lugs or saddle pieces to a steel structure or tank— Workman to endorse welding.

- (a) shall not depart for any purpose whatever, leaving a lug or saddle piece partially and incompletely welded; and

- (b) shall endorse his initials, with a durable crayon, on the tank, immediately adjacent to every lug or saddle piece that has been finally and completely welded.

Division 6.—Boatswains' Chairs.

- Interpretation. 35. In this Division—  
“boatswain’s chair” means an appliance suspended from an overhead support and designed to carry a workman in a seated position.
- Forbidden use. 36. A person under the age of eighteen years shall not work on, use, erect or operate a boatswain’s chair.
- Notice. 37. (1) Where a boatswain’s chair is erected or used over an area that is a thoroughfare a notice shall be erected below the overhead support of the boatswain’s chair so as to be visible to any person approaching the area.  
(2) The notice required by subregulation (1) of this regulation—  
(a) shall be of a rigid material  
(b) shall be not less than 750 mm in width and 450 mm in height;  
(c) shall bear the words “DANGER—MEN WORKING ABOVE” in black lettering of not less than 75 mm in height on a yellow background;  
(d) shall not bear any other words.
- Design and erection. 38. (1) A person shall not construct a boatswain’s chair unless its construction—  
(a) is of an approved type; or  
(b) conforms to these regulations.  
(2) A person shall not use a boatswain’s chair—  
(a) until it has been examined by an inspector; and  
(b) unless its use conforms to these regulations.
- Specifications. 39. A person shall not construct or use a boatswain’s chair unless—  
(a) the overhead needle support is properly secured in position and is counterbalanced to sustain a load of not less than three times the maximum weight to be suspended from the boatswain’s chair when in use;  
(b) the rope blocks for suspending, raising or lowering the boatswain’s chair consist of at least one two sheave upper block and at least one single sheave lower block that—  
(i) have metal carcasses;  
(ii) have sheaves not less than 100 mm in diameter that are grooved to accommodate the rope; and  
(iii) are fitted with a head fitting of a swivel closed eye type and the rope anchor or becket of the lower block shall not unless otherwise approved be welded to the block;  
(c) the suspending rope of the tackle is made either of manilla or of sisal fibre not less than 16 mm in diameter and is reeved to form a four-part rope tackle;  
(d) the sling supporting the seat—  
(i) is of 6 x 24 construction flexible steel wire rope with a diameter of not less than 8 mm;  
(ii) passes through holes in each corner of the seat to form a cross;  
(iii) is crossed under the seat;  
(iv) is arranged to form a loop fitted with a suitable thimble that is—  
(A) not more than 800 mm above the seat; and  
(B) fitted by a mild steel shackle not less than 9.5 mm in diameter to the swivel eye of the rope block;  
(v) is spliced or joined by two bulldog grips underneath the seat; and  
(vi) is fixed to the seat on the underside to prevent the seat from tilting in the sling;  
(e) the seat—  
(i) is constructed of timber of not less than 30 mm in thickness and 230 mm in width;

- (ii) has a distance exceeding 450 mm but not exceeding 550 mm between the slings; and
- (iii) has cleats made of timber not less than 75 mm x 25 mm sectional dimensions firmly fixed to the underside so that they bear the weight of the sling and prevent the seat from splitting.

Division 7.—Light Duty Suspended Staging.

40. In this Division—  
 “light duty suspended stage” means a working platform suspended from overhead supports and—
- (a) the means of lowering or raising the stage, whether those means are operated by hand or are power driven;
  - (b) the overhead supports, attachments and tracks; and
  - (c) the means of suspension.
41. A person shall not erect or use a light duty suspended stage unless—
- (a) it is of a design that conforms to these regulations or is of an approved design;
  - (b) it is constructed and assembled in conformity with these regulations;
  - (c) it is, when erected, capable of carrying a load three times in excess of the weight it is intended to carry when in use; and
  - (d) it has been examined by an inspector before it is used for the first time after—
    - (i) being dismantled and re-erected; and
    - (ii) any substantial period of disuse.
42. (1) A person under the age of eighteen years shall not erect, manage or work on a light duty suspended stage.
- (2) A parapet hook shall not be used for the purpose of suspending a light duty suspended stage without prior approval by an inspector.
43. (1) Where a light duty suspended stage is erected or used over an area that is a public place a notice shall be erected at each end of the area under the stage so as to be visible to any person approaching the area.
- (2) The notice required by subregulation (1) of this regulation—
- (a) shall be of a rigid material;
  - (b) shall be not less than 750 mm in width and 450 mm in height;
  - (c) shall bear the words “DANGER—MEN WORKING ABOVE” in black lettering of not less than 75 mm in height on a yellow background; and
  - (d) shall not bear any other words.
44. A light duty suspended stage shall not be erected or used unless it has—
- (a) overhead needle supports—
    - (i) that—
      - (A) are properly secured to the building or structure by bolts, by approved steel fittings or by lashing to the satisfaction of an inspector; or
      - (B) are counterbalanced by weights that—
        - (I) have a weight not less than three times the weight necessary to balance the weight of the load on the projecting part of the needle when the platform is fully loaded;
        - (II) are properly secured to the needle;
        - (III) are of purpose made metal or similar approved material; and
        - (IV) have their weight clearly stamped thereon;
    - (ii) that—
      - (A) if constructed of oregon timber—
        - (I) do not project a distance exceeding 1.2 m to the outer suspension point; and
        - (II) have minimum dimensions of 150 mm by 100 mm;

Interpretation.

Design and inspection.

Forbidden use.

Notice.  
 Amended by  
*G.G.*, 5/3/76,  
 p. 690.

Specification  
 of light  
 duty  
 suspended  
 stage.  
 Amended by  
*G.G.*, 3/8/79,  
 p. 2216.

- (B) if constructed of steel, are constructed, erected and used in accordance with the written directions of the Chief Inspector; or
  - (C) if constructed of steel tube approved for scaffolding in accordance with regulation 21, do not project from the building to the outer suspension point of each needle for a distance exceeding 560 mm and have two parallel tubes coupled together in a vertical plane; and
  - (iii) that are prevented from moving laterally or from rolling over;
  - (b) blocks made of metal with sheaves not less than 125 mm in diameter and comprising a double and single block, each with a swivel eye;
  - (c) falls—
    - (i) made of manilla or sisal cordage rope with a diameter not less than 20 mm or of such other rope as may be approved; or
    - (ii) where the presence of fumes is likely to affect them, are of at least 8 mm flexible steel wire;
  - (d) two mild steel hangers supporting the working platform, each made from a material having a cross-sectional area of 484 mm<sup>2</sup> of an approved design, and attached to a winch or winches for which they are designed and approved;
  - (e) a working platform that—
    - (i) is of rigid construction and neither more than 600 mm nor less than 500 mm wide;
    - (ii) has guard rails securely fixed around the outer edges of the stage; and
    - (iii) has fender boards of not less than 100 mm fitted to each side of the stage.
- Outriggers. 45. A person shall not fit or use an outrigger or projecting platform on a light duty suspended stage without approval.
- Loading. 46. The maximum load on a light duty suspended scaffold shall not exceed two persons and 25 kg and in any event not more than two persons shall work on the stage.
- Division 8.—Suspended Scaffolding.
- Interpretation. 47. In this Division—  
 “suspended scaffolding” includes the cantilevers, the means of securing them to the structure and the platform suspended from the cantilevers, together with the winches by which the platform is raised or lowered.
- Design. 48. A person shall not construct a suspended scaffolding unless—  
 (a) it is of an approved design; or  
 (b) its construction conforms to these regulations.
- Inspection. 49. A person shall not use a suspended scaffolding unless—  
 (a) its use conforms to the terms of the approval; and  
 (b) it has been examined by an inspector before it is used for the first time after—  
 (i) being dismantled and re-erected; or  
 (ii) any substantial period of disuse.
- Specifications of suspended scaffolding. 50. A person shall not use a suspended scaffolding unless—  
 (a) the structure used for supporting the suspended scaffolding is constructed so as to obtain a safety factor of at least 6 in the case of timber components or a safety factor of at least 4 in the case of steel components;  
 (b) the cantilevers that support the suspended scaffolding—  
 (i) are counterbalanced in an approved manner or are secured at their inner ends to the supporting structure by at least two bolts or other suitable fittings so that the bolts and fittings and the supporting structure to which the suspended scaffolding is fixed have a safety factor of at least 4 under conditions of maximum loading or are shored from a higher floor or a steel frame of the supporting structure so that every shore used is—

- (A) properly secured in its correct position in such a way as to prevent lateral movement of the cantilevers;
  - (B) of adequate strength for the purpose; and
  - (C) placed and fixed in such a way as to prevent undue loading on any part of the supporting structure;
  - (ii) are of rolled steel joist section at least equivalent to Australian Standard Beams 178 mm x 89 mm x 22 kg per metre of the Standards Association of Australia A 1/1965 Dimensions of Hot Rolled Steel Shapes and Sections for Structural Purposes;
  - (iii) do not project more than 2 m from the point of support on the supporting structure to the outer suspension point of the cantilever;
  - (iv) are spaced at a distance not exceeding 2.5 m from each other, measured from the centre line of adjacent cantilevers;
  - (v) are provided with stops at their projecting ends; and
  - (vi) have wire rope anchorages that are located vertically above the rope drum centres of the scaffolding machines and are capable of sustaining the ultimate strength of the suspension ropes;
- (c) the steel wire ropes used for the suspended scaffolding—
- (i) are of approved flexibility;
  - (ii) have a breaking strength of not less than seven times the intended maximum load; and
  - (iii) are effectively secured to anchorages;
- (d) the winches, scaffolding machines or similar mechanisms generally comply with Standards Association of Australia Specification for Scaffolding Machines (Hand Operated) A.S. B231/1966, and
- (i) are not used for lifting or lowering a suspended scaffolding unless the drawings or a specimen of the machine together with a complete description in writing of the manner in which it is set up, operated and maintained has been previously approved in writing;
  - (ii) are designed, set up, operated and maintained in accordance with these regulations and in accordance with the terms of approval;
  - (iii) are bolted to the steel frames on which the scaffold boards rest; and
  - (iv) are kept lubricated and maintained in an efficient state of repair, free from accumulation of dust, dirt or foreign matter while in use; and
- (e) the working platform—
- (i) has structural steel members that are designed, constructed and used so that under conditions of maximum loading the stress in each member shall not exceed the ultimate stress of the material used divided by the constant 4;
  - (ii) has four winch machines that comply with paragraph (d) of this regulation;
  - (iii) does not exceed 1.5 m in width;
  - (iv) is supported on steel angle bearers at least 51 mm x 51 mm x 8 mm;
  - (v) has a floor that—
    - (A) is formed of close laid planks of not less than 225 mm x 50 mm oregon or 235 mm x 38 mm karri that are bolted to the bearers where the pivot action or movement of adjacent platforms has been provided for; or
    - (B) is cleated together so that the ends of the planks do not become dislodged from the bearers and so that each plank overlaps its support by not more than 300 mm; and
  - (vi) is secured to the building or structure to prevent the platform from swaying.

Maximum loading of suspended scaffolding.

51. The maximum load that may be carried on a suspended scaffolding constructed under this Division is 545 kg and in any event the gross weight of the load together with that of the suspended scaffolding on any one cantilever shall not exceed 816 kg without approval.

Division 9.—Platforms and Edge Protection.

Specifications of working platform.

52. A person shall not use a working platform on scaffolding unless—
- (a) the width of the platform exceeds 450 mm but—
    - (i) where the platform is used either for the erection of scaffolding or rigging or on trestles not exceeding a height of 4.5 m, the width of the platform may be 225 mm; and
    - (ii) where the platform is used in the mortar trades, the width of the platform shall exceed 900 mm;
  - (b) the slope of the platform is set at a slope not exceeding 1 m vertical to 6 m horizontal;
  - (c) the scaffold plank overhangs its support by neither less than 150 mm nor more than 250 mm except where the plank is a lapped plank;
  - (d) where the working platform is erected to enable a person to work on a ceiling, the scaffold planks—
    - (i) are spaced at distances not exceeding 250 mm apart for a platform that does not exceed a height of 6 m; or
    - (ii) are close laid for a platform that exceeds a height of 6 m.

Specifications of platform planks.

53. (1) A person shall not use scaffolding unless the platform planks—
- (a) have minimum cross section dimensions—
    - (i) where the planks are oregon planks, of 225 mm by 38 mm; or
    - (ii) where the planks are karri planks—
      - (A) of 235 mm by 32 mm, in the case of planks that are green off saw; and
      - (B) of 216 mm by 30 mm, in the case of planks at 15 per cent moisture content; and
  - (b) span a distance not exceeding—
    - (i) 2 m in the case of heavy duty scaffolding; and
    - (ii) 2.5 m in the case of light duty scaffolding.
- (2) A person shall not, without prior written approval, use in scaffolding platform planks that are fabricated, laminated or moulded or made by any process of manufacture.

Guard rails.  
Amended by  
G.G. 14/11/75,  
p. 4221;  
G.G. 5/3/76,  
p. 690.

54. (1) A main contractor shall provide and maintain at every open edge of a platform at a height exceeding 3 m a guard rail—
- (a) that is constructed—
    - (i) of metal tubing with dimensions that conform to regulation 21 or 22 or metal of equivalent strength; or
    - (ii) of 75 mm x 50 mm hardwood timber or timber of equivalent strength;
  - (b) that has a height neither more than 1 m nor less than 800 mm from the surface of the platform;
  - (c) that has standards spaced at intervals not exceeding 3 m; and
  - (d) that is, where fixed in a position beyond the open edge, not more than 75 mm from that edge,
- but where the Chief Inspector is satisfied that in the circumstances of a particular case it is not practicable to provide guard rails as prescribed by this subregulation he may approve of an alternative method of providing edge protection.
- (2) Subregulation (1) of this regulation does not apply to work that is done either—
- (a) by a scaffolder or rigger for the purpose of erecting scaffolding or rigging; or
  - (b) by a person working on trestles at a height not exceeding 4.5 m.



(3) Notwithstanding subregulation (1) of this regulation, a main contractor shall provide every open edge of an accessway that exceeds a height of 1.5 m and on which a wheelbarrow is used, with a guard rail.

55. (1) A main contractor shall, unless otherwise approved, provide every working platform at a height that exceeds 3 m with a fender board that conforms to subregulation (2) of this regulation.

Fender boards.  
Amended by G.G. 3/8/79, p. 2216.

(2) A fender board shall consist of a platform plank or other material of equivalent strength and extending to a vertical height of not less than 200 mm from the surface of the platform situated around the outer edges of the platform; and, where a greater measure of safety is necessary, the vertical space between the guard rails and the platform plank shall be enclosed by netting or sheeting.

## PART V.—HOISTING APPLIANCES.

### Division 1.—General.

56. In this Part unless the context otherwise requires—

Interpretation.

“cantilever platform hoist” means a mobile hoisting appliance that is designed to discharge a load to a height not exceeding 11 m;

“friction winch” means a winch fitted with a lever or levers, for controlling, hoisting and braking and driven by a prime mover, at constant speed, to operate the hoisting motion through a friction drive, the load being lowered by the force of gravity;

“pivoted jib arm” means a hoisting appliance that has a power driven winch and an inclined steel jib that is capable of a pivoted action and the equipment and gear for the appliance;

“skip hoist” means a hoisting appliance, other than a tower hoist, driven or worked by the aid of any power, other than hand power, used for the sole purpose of raising or lowering concrete or similar material, in an automatic tipping bucket, and of which the direction of movement is restricted by a guide or guides, and includes the supporting structure, winch or winches, equipment and gear connected with the hoist;

“tower hoist” means a hoisting appliance, driven or worked by the aid of any power other than hand power, by which goods or materials can be raised or lowered and of which direction of movement is restricted by a guide or guides and the supporting structure, winch or winches, equipment and gear connected with the hoist.

57. (1) A person shall not—

Forbidden use.

- (a) ride;
- (b) instruct, permit or allow a person to ride; or
- (c) operate when a person is riding,

a cantilever platform hoist, tower hoist or skip hoist.

(2) Subregulation (1) of this regulation does not apply to a person who is qualified to carry out the erection, maintenance or dismantling of the hoisting appliance and is nominated to the Chief Inspector for that purpose.

### Division 2.—Cantilever Platform Hoists.

58. (1) A person shall not erect a cantilever platform hoist unless—

Design and inspection.

- (a) it is of an approved design; or
- (b) it conforms to these regulations.

(2) A person shall not use a cantilever platform hoist unless that use conforms to the terms of an approval or to these regulations.

59. (1) A person shall not use a cantilever platform hoist unless—

Specification for cantilever hoists.

- (a) the hoist is set up on an adequate foundation, and, where outriggers and screw jacks are fitted, the outriggers and screw jacks are properly packed and tightened to maintain the tower in a vertical position;
- (b) the area at the base of the tower is effectively guarded by rails 900 mm high set back 600 mm from the edge of the base of the hoist;

- (c) the tower is effectively supported at a level not exceeding 6 m from the base and again at vertical intervals of 3 m;
- (d) the clearance between the structure and the platform of the hoist is neither less than 50 mm nor more than 100 mm;
- (e) the tower and hoist is secured and maintained to prevent the platform from touching any adjacent structure;
- (f) the serial number identifying the hoist is clearly stamped in a conspicuous position on the hoist;
- (g) the maximum height of the platform—
  - (i) does not exceed 11 m; or
  - (ii) does not pass higher than two floor levels of a structure except where a landing platform with a width of at least 1 m is erected between the edge of the hoist platform and the outer face of the structure;
- (h) where the hoist is powered by a friction winch, the throw of the control lever of the winch does not exceed 60 degrees;
- (i) a device is fitted to prevent—
  - (i) over hoisting of the platform; and
  - (ii) slack rope on the hoist drum when the platform is at its lowest level;
- (j) the hoist platform—
  - (i) is fenced on the edge adjacent to the tower and the opposite edge to a height of 1 m by a 2.5 mm x 50 mm wire mesh that is secured to the corner posts and top and bottom rails;
  - (ii) is fitted, at the access ends and at a height of 1 m from the surface of the platform, with chains not less than 8 mm thick; and
  - (iii) has a notice in black letters 75 mm in height on a yellow background that states the safe working load and bears the words "PERSONS SHALL NOT RIDE ON HOIST PLATFORM" on a durable surface that is fixed to a conspicuous position; and
- (k) the suspension system of the hoist incorporates a clamping device that locks the platform to the guide runners in the event of a hoist rope failure.

(2) The provisions of subregulation (2) of regulation 64 apply so far as are applicable to a cantilever hoist the platform of which exceeds a height of 11 m.

(3) No person shall use a friction winch on or after the day that is five years after the coming into force of these regulations.

#### Division 3.—Tower Hoists and Skip Hoists.

- |                           |                                                                                                                                                                                                                                                                                                                                                                                                                                |
|---------------------------|--------------------------------------------------------------------------------------------------------------------------------------------------------------------------------------------------------------------------------------------------------------------------------------------------------------------------------------------------------------------------------------------------------------------------------|
| Driver's qualifications.  | 60. A person shall not drive or operate the winch of either a tower hoist or a skip hoist unless he holds a current Hoist Driver's Certificate issued under the Machinery Safety Act 1974.                                                                                                                                                                                                                                     |
| Application for approval. | 61. A person shall not construct or use a tower hoist unless— <ul style="list-style-type: none"> <li>(a) the design, drawings and design calculations of the tower hoist or skip hoist have been approved in writing; and</li> <li>(b) the construction and use of the tower hoist or skip hoist conform to the approval given under paragraph (a) of this regulation or with these regulations as the case may be.</li> </ul> |
| Inspection.               | 62. A person shall not use a tower or skip hoist until it has been inspected and approved for use by an inspector.                                                                                                                                                                                                                                                                                                             |
| Testing before use.       | 63. A person shall not use a tower hoist or a skip hoist unless it has been tested— <ul style="list-style-type: none"> <li>(a) with a weight that is 25% in excess of its safe working load when it is being tested for the first time and before it has gone into service; and</li> <li>(b) with a weight that is 10% in excess of the safe working load whenever it is subsequently re-erected.</li> </ul>                   |

64. (1) Except where written approval to that effect has been given, a person shall not use a tower hoist or a skip hoist where the tower of the hoist—
- Tower  
hoists and  
skip hoists.
- (a) has a height in excess of 20 m; or
  - (b) has a height that exceeds by more than 20 m the highest tie that fixes the hoist to the building or structure,
- but in any event—
- (c) the height of a tower hoist shall not exceed the highest set of its guys by more than 6 m; and
  - (d) the height of a skip hoist shall not exceed the highest set of its guys.
- (2) A person shall not use a tower hoist or skip hoist unless—
- (a) the tower of the hoist—
    - (i) is effectively guyed at each corner or tied to the supporting structure at vertical intervals not exceeding 10 m; and
    - (ii) is securely and completely enclosed by 50 mm x 2.5 mm diameter wire mesh up to a height that is not less than 2 m above the highest landing;
  - (b) the guys are of flexible steel wire rope not less than 12 mm in diameter and are capable of adjustment by means of turnbuckles or stretching screws;
  - (c) the turnbuckles or stretching screws used in the hoist—
    - (i) are of a closed eye type;
    - (ii) are positively secured and prevented from unscrewing; and
    - (iii) if used with 12 mm diameter guys, are 16 mm in diameter;
  - (d) the hoist winches, controls and any electrical equipment are housed in a weatherproof building that affords overhead protection for the hoist driver;
  - (e) the diversion sheave at the base of the hoist and the lead rope from the diversion sheave to the winch and any other dangerous parts of machinery are effectively guarded and protected from falling material;
  - (f) the fleet angle between the diversion sheave and winch drum does not exceed—
    - (i) five degrees on each side of the centre line between the diversion sheave and the winch drum in the case of grooved drums; or
    - (ii) three degrees on each side of the centre line between the diversion sheave and the winch drum in the case of plain drums;
  - (g) the winch operating the hoist—
    - (i) is of a positive drive up-drive down type which does not incorporate any form of declutching permitting free fall;
    - (ii) is fitted with a "dead man" control;
    - (iii) has an emergency brake that can be locked in the "on" position fitted to the main hoist drum; and
    - (iv) is not operated by remote control;
  - (h) it has a power or mechanical interlock that—
    - (i) prevents the top suspension point of the platform or skip from coming closer than 2 m to the underside of the head sheave support; and
    - (ii) prevents slack rope from occurring on the winch drum when the platform or skip is at its lowest level;
  - (i) the platform—
    - (i) has fixed on it a notice in 75 mm black letters on a yellow background indicating the safe working load with the words "PERSONS SHALL NOT RIDE ON HOIST PLATFORM";
    - (ii) does not exceed an area of 3.35 m<sup>2</sup> without approval;
    - (iii) has a maximum clearance not exceeding 50 mm with the inside of the tower except where—
      - (A) the platform is fitted with a toe board;
      - (B) a guard rail is fixed 900 mm above the platform; and
      - (C) the area between the guard rail and the toe board is enclosed by 50 mm x 2.5 mm diameter wire mesh;

- (iv) has suspension gear that incorporates a clamping device that locks the platform to the guide runners in the event of a hoist rope failure;
  - (j) it has connected to every level used for loading or unloading, an independent signalling system—
    - (i) that enables clear and audible communication with the winch driver;
    - (ii) that indicates to the driver by a lighted signal, whether or not the gates are in a closed position; and
    - (iii) that, where it consists of an electric circuit, has a voltage that does not exceed 32 volts and has all equipment and wiring adequately protected;
  - (k) it has, fitted to the hoist unit, an effective mechanical indicator that shows the driver the position of the platform in the tower;
  - (l) the base of the tower is bolted in each of its corners to an approved foundation.
- (3) A person shall not use a tower hoist or a skip hoist unless there is installed at every level that is used for loading or unloading a substantial gate that—
- (a) is not less than 1.5 m in height; and
  - (b) is connected to a 32 volt electric interlocking system so that if any gate is not fully closed the power supply to the winch is positively disconnected.
- (4) Subject to subregulation (2) of regulation 59, a person shall not use a friction winch in a hoisting appliance unless—
- (a) the hoisting appliance is a skip hoist; and
  - (b) the control lever of the winch has a throw not exceeding 60 degrees.
- (5) A person shall not use, operate or control a skip hoist or a tower hoist that is loaded in excess of the weight indicated on the notice fixed to the platform under subparagraph (i) of paragraph (i) of subregulation (2) of this regulation.

Maximum loading.

#### Division 4.—Miscellaneous Hoisting Appliances.

Slewing jib unit.

65. (1) A person shall not erect or use a slewing jib unit on a skip hoist or a tower hoist unless—
- (a) a guy rope is secured to each corner of the tower at the level of—
    - (i) the jib pivot; or
    - (ii) the jib head support;
  - (b) there is incorporated in the tower an interlocking throw-over switch that prevents the slewing jib and the hoist platform or skip from being operated at the same time;
  - (c) a fibre tail rope not less than 16 mm in diameter is attached to the jib providing positive control of slewing motions;
  - (d) the lifting hook is a swivelling type safety hook; and
  - (e) a notice in 75 mm black letters on a yellow background indicating the safe working load in kilograms is fixed at the loading point.

Maximum loading.

- (2) A person shall not use, operate or control a slewing jib that is loaded in excess of the weight indicated in the notice fixed under paragraph (e) of subregulation (1) of this regulation.

Pivoted jib arm.

66. (1) A person shall not erect or use a pivoted jib arm unless—
- (a) the outrigger and its attachments including the fittings and bolts attaching the outrigger to the building have and are maintained at a safety factor of 6;
  - (b) the hoisting rope passes around the pulley block attached to the outrigger and then around a diversion sheave to the winch;
  - (c) the diversion sheave and the lead rope from the diversion sheave to the winch and all other dangerous parts of the machine are effectively covered;

- (d) the hoist winch—
- (i) is of a positive drive up-drive down type;
  - (ii) does not incorporate any form of declutching permitting free fall; and
  - (iii) is fitted with a "dead man" control and a manually operated brake on the main hoist drum;
- (e) it has a swivel type safety hook;
- (f) a notice in 75 mm black letters on a yellow background clearly indicating the safe working load in kilograms is erected at the point of loading;
- (g) where there is a likelihood of the load being caught in an obstruction, smooth skid boards of adequate width or tag lines are provided;
- (h) where there is danger from falling material, overhead protection is provided for the driver; and
- (i) the loading area is effectively guarded by rails not less than 1 m high.

(2) A person shall not use or operate a pivoted jib arm that is loaded in excess of the weight indicated on the notice required by paragraph (f) of subregulation (1) of this regulation.

Maximum loading of pivoted jib arm.

#### PART VI.—MISCELLANEOUS GEAR.

67. (1) A person shall not use a ladder on work to which the Act applies unless—

- (a) where the ladder is of timber, it is constructed to comply with A.S. 1688 and 1689-1974 "Portable Timber Ladders" sections 2 (except clauses 3 and 7), 3, 4, 5, 7 and 10; or
- (b) where the ladder is of aluminium—
  - (i) it is constructed to comply with B.S. 2037 "Aluminium Ladders, Steps and Trestles"; and
  - (ii) it does not exceed a height of 9 m, in the case of a single ladder, or a height of 15 m, in the case of an extension ladder.

Ladders.  
Amended by  
G.G. 5/3/76,  
p. 690.

(2) Notwithstanding subregulation (1) of this regulation, a person may use special timber or aluminium ladders with approval.

(3) A person shall not use a steel ladder on work to which the Act applies unless it is of an approved design and construction.

(4) A person shall not use any type of individual rung ladder as temporary access to a work place unless the ladder complies with A.S. 1657-1974 "Fixed Platforms, Walkways, Stairways and Ladders" section 5.8.

(5) A person shall not use ladder brackets.

68. (1) A person shall not use eye splices in work to which the Act applies unless they conform to subregulation (2) of this regulation.

Splicing.

(2) Eye splices—

- (a) shall have not less than three tucks with each whole strand of rope, and two tucks with one-half of the wires cut out of each strand under and over against the lay of the rope; and
- (b) shall be tightly drawn and neatly made.

(3) A person shall not use mechanical splicing or terminal fittings unless they are made and used in an approved manner.

69. The safe working load of flexible steel wire used as gear is—

- (a) in the case of permanent standing guys, one-quarter of the guaranteed breaking strength load; and
- (b) in any other case, but not including the lifting of persons, one-fifth of the guaranteed breaking strength load.

Safe working load of flexible steel wire.

70. The owner or the main contractor shall ensure that all dangerous parts of power driven equipment are fitted with guards at all times when the equipment is in operation.

Guards on power driven equipment.

- Clamps. 71. A person shall not use a lifting clamp unless it—  
 (a) has been approved; and  
 (b) is clearly and permanently marked with the safe working load.
- Hooks. 72. A person shall not use a hook for raising or lowering on any crane or  
 Substituted by hoisting appliance other than a hoist block unless it is provided with an efficient  
*G.G. 5/3/76,* device or safety attachment that prevents the displacement of the sling or load  
*p. 690.* from the hook.
- Slings. 73. (1) A person shall not raise or lower or suspend a load on—  
 (a) a knotted chain or a knotted wire rope; or  
 (b) a chain that has been shortened or joined to another chain by bolts and nuts.  
 (2) Except in the case of a double legged sling having an included angle of less than 60 degrees under the hook, multiple legged slings that are lifted by a single hook shall be attached to the hook by a shackle, ring or link with a strength that is adequate for the load to be lifted by the hook.  
 (3) A person who operates or loads a sling—  
 (a) shall, by packing or other means, prevent the sling from coming into contact with any sharp edge of a load; and  
 (b) shall prevent the load from damaging the sling, rope or brace.  
 (4) A person shall not—  
 (a) exceed the safe working load of a sling; or  
 (b) arrange the sling legs at an angle that would induce in the sling leg a tension exceeding the safe working load of the sling.
- Appliances on scaffolding. 74. (1) A person shall not attach or mount on scaffolding an appliance or a machine, including a pipeline for pumping concrete, that is used for lifting or moving material unless—  
 (a) the scaffolding is constructed in such a manner that it can withstand the maximum additional forces that may arise during the operation of the appliance or machine; and  
 (b) the appliance or machine is tied securely to the scaffolding.  
 (2) A main contractor shall not mount an appliance or machine with a safe working load in excess of 260 kg on scaffolding unless he has satisfied the Chief Inspector that the strength of the scaffolding conforms to the requirements of subregulation (1) of this regulation.
- Use of drums. 75. A person shall not use a drum as scaffolding unless—  
 (a) the height of the platform supported by the drum does not exceed the height of one drum placed on end;  
 (b) the drums are placed on end; and  
 (c) the drum is placed on the ground or on an internal floor.
- Lift boxes. 76. (1) A person shall not use a lift box to carry a load exceeding 3 tonnes.  
 (2) A person shall not use a lift box that is designed to carry a load of 3 tonnes unless—  
 (a) it is constructed of either—  
 (i) 50 mm timber properly framed together; or  
 (ii) welded steel with a strength equivalent to that of 50 mm timber;  
 (b) it has two carrying straps that—  
 (i) are not less than 75 mm by 15 mm mild steel flat bar passing under the bottom and up the two sides of the box;  
 (ii) are either secured to the timber with 15 mm diameter bolts or, in the case of a steel box, welded to the box; and  
 (iii) have eyelet holes formed in their top ends to receive the slings.  
 (3) A person shall not lift bricks or other similar material at a site unless the container for lifting and the manner of the lifting is approved.

77. Except where approval to that effect has been given a person shall not on a site use a landing platform in conjunction with a hoisting appliance unless— Landing platforms.

(a) in the case of a platform that is intended to carry a load not exceeding 1 tonne, the platform—

- (i) has an outboard area not exceeding 3.5 m<sup>2</sup> and has a projection not exceeding 2 m;
- (ii) is supported by two rolled steel joist outriggers not less than 178 mm x 89 mm x 22 kg per metre not less than 5.5 m in length;
- (iii) has outriggers secured to the supporting structure by propping or bolting to provide a safety factor of 4 and so that there is no lateral movement;
- (iv) has floor beams of not less than 102 mm x 51 mm x 10 kg rolled steel channel spaced at distances not exceeding 560 mm measured from centre to centre;
- (v) has a decking either of 235 mm by 32 mm karri planks fixed to each floor beam with 9 mm diameter cup-head bolts or of 6 mm checker plate welded all round with 75 mm runs at 300 mm centres;
- (vi) has decking planks that are close laid preventing the passage of dust or other materials;
- (vii) has 6 mm continuous all round fillet welds joining the floor beams to outriggers;
- (viii) has cross bracing of mild steel flat bar of not less than 64 mm x 6 mm between the outrigger beams welded to, and flush with, the top of the floor beams;
- (ix) has a notice indicating the safe working load of the platform secured in a conspicuous position; and

(b) in the case of a platform that is intended to carry a load not exceeding 3 tonnes, the platform—

- (i) has an outboard area not exceeding 6 m<sup>2</sup> and has a projection not exceeding 2.5 m;
- (ii) is supported by two universal beam outriggers not less than 310 mm x 125 mm x 46 kg per metre not less than 7.25 m in length;
- (iii) has outriggers secured to the building by propping or bolting to give a safety factor of 4 and so that there is no lateral movement;
- (iv) has floor beams of not less than 152 mm x 76 mm x 18 kg per metre spaced at—
  - (A) centres not exceeding 450 mm apart in the case of decking made of 235 mm x 32 mm karri planks that are fixed to each floor beam with 9 mm diameter cup-head bolts; or
  - (B) centres not exceeding 575 mm apart in the case of decking made of 9 mm checker plate that is welded all round with 75 mm runs at 300 mm centres;
- (v) has decking planks that are close laid to prevent the passage of dust or other materials;
- (vi) has at least 10 mm continuous all round fillet welds joining the floor beams to the outriggers;
- (vii) has a cross bracing of mild steel flat bar of not less than 75 mm by 6 mm between the outrigger beams welded to, and flush with, the top of the floor beams; and
- (viii) has a notice indicating its safe working load secured in a conspicuous position.

## PART VII.—GENERAL SAFETY.

### Division 1.—Gantries, Hoardings and Barricades.

78. In this Part—

“barricade” means a temporary fence consisting of rigid vertical and horizontal members;

Interpretation.

“gantry” means a structure that is used—

- (a) for the overhead protection of persons; and
- (b) for the support of materials and workmen;

“hoarding” means a substantial and fully sheeted fence or screen.

Main contractor to provide public safety. Amended by G.G. 5/3/76, p. 690.

79. (1) Subject to subregulations (2) and (3) of this regulation, where work to which the Act applies is carried out or is to be carried out on a site that is near or adjacent to the property boundary or to any public place the main contractor or sub-contractor as the case may be shall erect—

- (a) a barricade, if it is necessary only to exclude persons other than workmen from the site; or
- (b) a hoarding, if it is necessary to provide a greater measure of safety than would be provided by a barricade; or
- (c) a gantry, if the height of any part of the building or structure exceeds or is intended to exceed a height that is twice the horizontal distance between the building or structure or the proposed building or structure and the boundary of any public place adjacent to the site.

(2) Where a site adjoins a footway that is used by the public an inspector may, if he is satisfied that the requirements of public safety will be adequately provided for by the erection of scaffolding instead of a gantry, permit the main contractor to erect on the footway scaffolding that—

- (a) has the first stage decked over to the full width of the footway, but if the scaffolding does not extend to the full width of the footway—
  - (i) the scaffolding shall have, at the first stage, a fan not less than 2 m in width projecting at an angle of 45 degrees from the vertical extending along the outside and returned at both ends of the scaffolding; and
  - (ii) both the decking and the fan of the scaffolding shall be placed in position before any work is commenced;
- (b) provides, where necessary, access for materials through openings that are railed off to prevent the public from passing under the scaffolding at the point of access;
- (c) has night lights at both ends, at access ways through the scaffolding and elsewhere as directed by an inspector;
- (d) has standards that are painted white to a height of 2.05 m and all sharp and protruding members protected by hessian or a similar material;
- (e) where the type of work so requires, has a fender board and protective screen to the outside and ends of the scaffolding; and
- (f) conforms to any safety requirements that are, in the opinion of an inspector, necessary for the protection of the public and the workmen.

(3) Where the Chief Inspector is satisfied that the work to be carried out consists only of demolition work and that the public safety is not endangered he may give the main contractor or sub-contractor a permit to delay the erection of the barricade, hoarding or gantry as the case may be until the demolition work reaches such a point as the Chief Inspector specifies in the permit.

Gates not to open outwards.

80. (1) A main contractor shall not erect a hoarding on a site unless the gates or doors of the hoarding are designed so that they do not open on the area outside the site.

(2) Gates and doors in a hoarding shall be kept closed at all times except to allow access to or egress from the site.

Design and approval of gantries.

81. A main contractor shall not erect or commence to erect a gantry until the plans and specifications of the gantry have been approved.

Minimum load capacity of a gantry. Amended by G.G. 5/3/76, p. 690.

82. A person shall not use a gantry unless it is designed to withstand a loading of—

- (a) 730 kg/m<sup>2</sup>, where the gantry is to be used for storing material or erecting scaffolding or where loads are to be lifted over it;
- (b) 360 kg/m<sup>2</sup>, where the gantry is to be used for carrying site offices or for demolition work; or
- (c) 100 kg/m<sup>2</sup>, where the gantry is to be used only to provide public protection during alterations, painting or similar work.



83. A person shall not use a gantry for any work to which the Act applies unless the gantry—
- Specifications of gantries.  
Amended by G.G. 5/3/76, p. 690.
- (a) where it is erected over a footway that is used by the public, provides a minimum vertical distance of 2.05 m from the footway to any horizontal or diagonal transverse member;
  - (b) has no members closer than 300 mm to the edge of a road kerb;
  - (c) has standards that—
    - (i) are founded on approved adjustable base plates and sole plates with minimum dimensions of—
      - (A) 216 mm in width by 60 mm in thickness in the case of a gantry designed for 730 kg/m<sup>2</sup>; or
      - (B) 216 mm in width by 30 mm in thickness in the case of a gantry designed for 360 kg/m<sup>2</sup> or less,
 that extend over the full length of the gantry; and
    - (ii) are painted white to a height of 2.05 m;
  - (d) has a main decking that—
    - (i) consists of closely laid planks that conform to paragraph (a) of subregulation (1) of regulation 53 covered by an independent water proof cover of metal or other approved material capable of effectively shedding water and excluding dust and rubble from the footway area; and
    - (ii) the cover has a slope of at least one in forty, but where site offices are placed on the gantry the decking and cover may be omitted if water, dust and rubble do not enter the footway area below the gantry;
  - (e) has a continuous handrail located on the outer standards 900 mm above the footpath level;
  - (f) has night lights that provide adequate illumination of the area at each end and under the gantry;
  - (g) has a hoarding that extends either to a height of at least 1.8 m on the inner building side of the standards or, in the case of demolition work, to the under side of the decking;
  - (h) has any area between the hoarding and the under side of the decking enclosed by a wire mesh of at least 2.5 mm with a maximum aperture of 50 mm;
  - (i) has any fittings or sharp protruding members protected by wrappings of hessian or similar material;
  - (j) has the outer edge and ends of the main decking provided with a rigid guard rail with the area between the surface of the decking and the guard rail enclosed by a fender board;
  - (k) extends at least 2 m beyond each end of the limits of the site or any working platform erected adjacent to the site;
  - (l) provides a maximum width of clearway for pedestrian traffic at all times; and
  - (m) is braced or tied to substantial ground anchors or otherwise secured from overturning.
84. A person shall not construct a gantry of steel tubing unless the gantry—
- Steel tubing gantries.  
(Appendix A.)
- (a) is of a design that conforms to Appendix A to these regulations;
  - (b) has steel tubings and fittings that conform to regulations 20, 21, 23, 24, 25 and 26;
  - (c) has standards that are spaced at distances not exceeding 2 m; and
  - (d) is braced to form a rigid stable structure.
85. A gantry constructed of fabricated steel shall be designed to conform to regulations 82 and 83 and all drawings and certified design calculations shall be submitted for approval.
- Fabricated steel gantries
86. A person shall not construct a gantry of timber unless the gantry—
- Timber gantries.  
(Appendix B.)
- (a) is designed to conform to Appendix B to these regulations;
  - (b) is constructed of standard grade hardwood with a strength of Group B; and
  - (c) has standards spaced at distances not exceeding 2 m.

Protection to remain in position.

87. A person shall not remove a barricade, a hoarding or a gantry until the work for which it was erected has been completed.

Division 2.—Miscellaneous Provisions.

Risk to safety or health to be avoided.  
Inserted by G.G. 5/3/76, p. 690.

87A. Without affecting any other of the provisions of these regulations or any provision of any Act or regulations or by-laws under any Act all parts of the site as defined, and all materials, gear, and like things used or to be used in construction work on the site shall be maintained, kept, located, or stored in such manner and condition as does not constitute a risk to the safety or health of any person.

Main contractor to provide safety.  
Amended by G.G. 5/3/76, p. 690.

88. (1) The main contractor shall, during the whole period of carrying out any work to which the Act applies, provide protection for all persons within or in the vicinity of the site by—

- (a) guarding or covering all holes or openings having dimensions greater than 200 mm diameter or 200 mm x 200 mm in floors or elsewhere and, in the case of holes or openings which have dimensions not exceeding 2 metres in any direction other than lift shafts, stair wells and the like in floors of a concrete building or structure, guarding them with wire mesh that—
    - (i) has wire at least 4 mm diameter;
    - (ii) has maximum apertures of 100 mm x 100 mm;
    - (iii) is embedded, at least 200 mm in the edges of the surrounding concrete;
    - (iv) is embedded in the upper half of the slab with a minimum concrete cover of 20 mm or, with the approval of the Chief Inspector, is embedded in the lower half of the slab with a minimum cover of 30 mm;
    - (v) shall not be used as a working platform; and
    - (vi) shall have only the minimum area removed for the installation of services immediately prior to the installation of such services;
  - (b) securely fixing and marking all covers in clearly legible lettering not less than 75 mm in height with the words "DO NOT REMOVE—HOLE BENEATH";
  - (c) fixing guard rails down all the stairs and across all landings and shaft openings;
  - (d) providing adequate natural or artificial lighting to all accessways and places of work;
  - (e) controlling the movement and speed of vehicles;
  - (f) providing safe means of access to and egress from working places in proportion to the number of the workmen on the working places;
  - (g) providing access ladders that are secured and that protrude at least 1 m beyond a landing or a working platform;
  - (h) providing the site with accessways, or other means of communication that—
    - (i) are at least 450 mm wide;
    - (ii) where consisting of boards, are bolted together, if necessary, in a manner that will prevent unequal sagging;
    - (iii) have guard rails that conform to regulation 54; and
  - (i) causing all floors, landings, runs, accessways, platforms, scaffolding or places where scaffolding is to be erected or where persons are required to work, to be cleared and to be kept cleared of rubbish and any material not required for immediate use.
- (2) An accessway shall not have a slope in excess of 1 m vertical in 8 m horizontal unless—
- (a) where the slope exceeds 1 m vertical in 8 m horizontal but does not exceed a slope of 1 m vertical in 2.7 m horizontal, cleats shall be provided on the accessway; and
  - (b) where the slope exceeds 1 m vertical in 2.7 m horizontal the accessway shall consist of steps.

Parts of scaffolding not to be removed.

89. A person shall not remove or alter a part of scaffolding without the authority of the person who is in charge of the site.

90. No person shall, without written approval to that effect, operate or use or suffer or permit a person to operate a crane or a hoisting appliance to lift, lower or suspend a person. Lifting persons by hoisting appliance.
91. Where an electric line crosses any roadway or accessway on a site the main contractor shall erect across that roadway or accessway on each side of and at a distance of 6 m from such electric line, a flagged catenary wire, at a height of 600 mm less than the electric line, as a warning to all mobile equipment. Wires crossing roads.
92. (1) A main contractor or sub-contractor shall, before commencing any work to which the Act applies, satisfy himself by inquiry from the appropriate authority supplying water, gas or electricity in the area, of the location and nature of its service in the area. Notification of supply authority.
- (2) Where on a site—
- (a) a main contractor or sub-contractor intends—
    - (i) to erect metal scaffolding within 4.5 m of electric wires; or
    - (ii) to use any gear within 3 m of electric wires; or
  - (b) it is possible for any person through any medium to come into contact with electric wires that have not been adequately insulated or effectively shielded or otherwise made safe,
- the main contractor shall not erect any scaffolding or use any gear or allow any person to carry out any work until the main contractor—
- (c) has notified the supply authority of the presence of the electric wires; and
  - (d) has taken such action as the supply authority may require to make the wires safe.
- (3) Where the provisions of subregulation (2) of this regulation have not been complied with an inspector may take such action as he deems necessary to ensure that it is safe for the work to proceed.
93. A person shall not carry out any steel trench sheeting or piling unless— Steel trench sheeting or piling.
- (a) the device lifting or positioning the steel trench sheet or pile is fitted with an approved mechanical device that positively locks the lifting device to the pile or steel trench sheeting;
  - (b) the steel trench sheet or pile is controlled either by a tail rope or in some other approved manner; and
  - (c) the hammer used for driving the steel trench sheet or pile is hooked from the supporting crane except where—
    - (i) the hammer is fitted with guide runners that have a maximum clearance between the runners and the steel trench sheet or pile and sufficient projection below the top of the steel trench sheet or pile so that the hammer does not incline more than 5 degrees from the vertical; and
    - (ii) the steel trench sheet or pile has been driven into the ground not less than 25 per cent of its length.
94. (1) Where work to which the Act applies is being carried out a person shall— Lifting and lowering material.
- (a) carefully lower any scaffolding, formwork, falsework or gear;
  - (b) properly secure any material or gear that is being raised, suspended or supported;
  - (c) use—
    - (i) an approved hoisting appliance; or
    - (ii) a completely enclosed chute discharging either into disposal hoppers or into an area that is completely enclosed by a hoarding at least 2 m in height,
 for the removal of material or debris;
  - (d) where the area is open to the public or where an inspector so requires, lift or lower material from or onto an area that is fitted with an approved boom gate that—
    - (i) has an effective width of 2 m and a height of 1 m;
    - (ii) is painted white;

- (iii) is fitted with a yellow diamond shape sign, 600 mm high bearing the words in black letters "CRANE WORKING OVERHEAD";
- (iv) is hinged and is capable of being locked in the working and non-working positions;
- (e) store rubbish, building material and plant away from footpaths and roadways; and
- (f) where a pipeline used for supplying or discharging air, water, concrete or other material crosses a thoroughfare, provide the pipeline with an adequate non-slip ramp.

(2) A person shall not while carrying out any work to which the Act applies throw or drop any scaffolding, formwork, falsework or gear from any building or structure.

#### Division 3.—Electrical Work.

Interpretation. 95. In this Division unless the context otherwise requires—  
"approved" means approved by the supply authority.

Switchboards. Substituted by G.G. 15/10/76, pp. 3706-7. 96. (1) Where any work on a site requires the provision of electric power the main contractor shall ensure that—

- (a) only an approved main distribution switchboard is used, that it is of an approved size, loading and capacity and that it is situated in an approved area on the site;
- (b) only approved sub-mains and rising sub-mains are used; and
- (c) any distribution switchboard used—
  - (i) is enclosed in an approved robust surround;
  - (ii) provides outlets of 250 volts through approved three pin sockets protected by overload circuit breakers; and
  - (iii) is located as near as practicable to the work being performed.

(2) Where electric power is used to illuminate a site the electric lighting system—

- (a) if it is a permanent installation, shall be installed in accordance with AS 3000 Part I-1976 S.A.A. Wiring Rules;
- (b) if it is not a permanent installation—
  - (i) shall consist of approved portable flood lights, hand lamps or moulded festoon lights;
  - (ii) shall operate at a potential not exceeding 32 volts; or
  - (iii) shall be protected by an approved current operated core balance earth leakage system circuit protection which conforms to regulation 98.

(3) Every globe in an electrical circuit, the potential of which exceeds 32 volts, shall be protected by a guard.

(4) A main contractor or sub-contractor shall ensure that electric power driven equipment used on a site is connected directly through a main switchboard or distribution board and not otherwise and that all connections are made in the approved manner.

Connections. Substituted by G.G. 15/10/76, p. 3707. 97. (1) Where portable electric power driven equipment is provided on a site the main contractor or sub-contractor shall ensure that all such equipment—

- (a) conforms to the requirements of the AS 3000 Part I-1976 S.A.A. Wiring Rules or of the supply authority but where the former is inconsistent with the latter, the latter shall prevail;
- (b) is connected to its electric supply point by flexible extension cords that are—
  - (i) joined in an approved manner;
  - (ii) as far as practicable, protected or kept clear of the floor or the ground and so as to prevent injury or damage.

(2) Notwithstanding subparagraph (ii) of paragraph (b) of subparagraph (1) of this regulation, where a flexible extension cord is in any area that is subject to vehicular traffic the cord shall be kept clear of the floor or ground or protected so as to prevent injury or damage.

98. A main contractor or sub-contractor on a site shall ensure that every circuit supplying electric power to electric power driven equipment which is alternating current with a potential of 32 volts or more has an approved current operated core balance earth leakage circuit protection that is—

- (a) set to operate—
  - (i) in the case of electric power driven equipment with a potential not exceeding 250 volts, at a current leakage not exceeding 30 milliamperes;
  - (ii) in the case of electric power driven equipment with a potential exceeding 250 volts but not exceeding 650 volts, at a current leakage not exceeding 1 ampere;
- (b) provided with a testing facility; and
- (c) fully operative at all times.

Power driven equipment.  
Substituted by G.G. 15/10/76, p. 3707.  
Amended by G.G. 3/8/79, p. 2216.

#### Division 4.—Protective Equipment and Health.

99. (1) Every person entering, or employed on construction work or excavation work—

- (a) exceeding, or likely to exceed a height of 6 m above ground level or surface water level;
- (b) on which scaffolding is erected to a height exceeding 6 m;
- (c) at a depth exceeding 2 m below ground level; or
- (d) that consists of demolition work,

shall, except where working under permanent overhead protection or where exempted under the provisions of this regulation, wear an approved industrial safety helmet.

(2) Every industrial safety helmet shall conform to the requirements in A.S. Z10—"1967 Industrial Safety Helmets" and shall be fitted with a clean head harness.

(3) A person is not required to wear a safety helmet if he produces a certificate issued by a duly qualified medical practitioner that the wearing of a safety helmet would be injurious to that person's health.

(4) (a) The main contractor shall cause a notice to be displayed at the main entrances of all construction work on which helmets are required by this regulation to be worn.

(b) The notice mentioned in paragraph (a) of this subregulation shall be not less than 750 mm in width and 450 mm in height, and bear only the words "SAFETY HELMET AREA. HELMETS MUST BE WORN ON THESE WORKS" in black lettering 75 mm in height on a yellow background.

100. Except where the type of work so requires, a person who is on a site shall wear substantial footwear that completely covers his feet.

Footwear.

101. (1) Where a site has in or near it water to a depth that can give rise to risk either of injury or of drowning the main contractor shall provide life jackets or rescue equipment that are maintained ready for use.

Work near water.

(2) A life buoy and line provided under subregulation (1) of this regulation—

- (a) shall be of a type approved by the Harbour and Light Department; and
- (b) shall be placed in a readily accessible position.

102. (1) Where a workman is required to carry out work to which the Act applies in a position that would prevent compliance with regulation 54 the main contractor or sub-contractor shall provide the workman with a safety belt or harness that is attached to a safe anchorage.

Safety belts.

(2) The safety belt or harness required under subregulation (1) of this regulation shall conform to B.S. 1397: 1967 Specification for Industrial Safety Belts and Harness, but the Chief Inspector may approve of a design of hook in substitution for the hook specified in section 2.4.1 of that specification.

(3) Subregulation (1) of this regulation does not apply to—

- (a) a workman who is erecting scaffolding;

- (b) a rigger who is using structural members as a means of access to or egress from a working place on a site; or
- (c) a workman performing work on trestles.
- Noise. 103. The main contractor or sub-contractor shall as far as is practicable ensure that noise levels on a site do not exceed a level of 90 decibels measured by using the A weighting network curves as defined in A.S.—Z 37 and A.S.—Z 38; and, where the level of the noise is likely to exceed that level or is, in the opinion of an inspector, likely to be injurious to the health of a workman the main contractor or sub-contractor shall provide protective hearing equipment.
- Eye protection. 104. (1) A main contractor or sub-contractor shall as far as is practicable prevent injury to the eyes of workmen.
- (2) Where by reason of the danger of the work, or where required by an inspector so to do, the main contractor or sub-contractor shall provide eye protection that conforms to the Code of Recommended Practice for Industrial Eye Protection A.S. CZ7-1967.
- Fumes and dust. 105. (1) A main contractor or sub-contractor shall take effective measures to suppress or control the emission of gas, fumes, vapour or dust on a site.
- (2) Where—
- (a) an emission of gas, fumes, vapour or dust is likely to be injurious to the health of a person or is likely to cause an unsafe condition; or
- (b) he is required by an inspector so to do,
- a main contractor or sub-contractor shall provide the workmen with approved respiratory devices that conform to A.S. Z18-1968 Respiratory Protective Devices.
- (3) A person shall not use a compressor to supply air to a face mask or hood assembly unless the air intake is so located that there is no possibility of the compressed air being contaminated either by abrasives or by fumes from any source.
- (4) A person shall not use a respiratory device unless—
- (a) the respiratory device has an efficient filter to remove dust, oil, gas or any other harmful or potentially harmful contaminants; and
- (b) where the air for the respiratory device is supplied from a compressed air system that is not a self-contained system, the system has—
- (i) an efficient conditioner that delivers air at a temperature not lower than 15.5° C and not higher than 26.5° C;
- (ii) an efficient condensate trap fitted with a drain cock that removes any condensed liquid;
- (iii) an efficient pressure regulating device; and
- (iv) a valve for each operator so as to allow him to regulate the air in accordance with his needs.
- Blasting in public places. 106. Where abrasive blasting is carried out on or adjacent to a public place, the main contractor shall adopt adequate precautions to trap any abrasive overspray and prevent general pollution of the air.
- Fire hazards. 107. Where there is a risk of a fire on a site and an adequate supply of water it not available the main contractor shall provide on the site a supply of regularly maintained and efficient fire extinguishers of such a type and capacity as is suitable for the control of any type of fire likely to arise from the type of work being carried out on the site.
- Gases, liquids and vapours, etc. Amended by G.G. 5/3/76, p. 691. 108. (1) Where work to which the Act applies is to be carried out in a place in which noxious gases, flammable liquids or vapours or any harmful matter are present or are likely to be present in or near the work the main contractor shall carry out tests to ensure that the air is capable of supporting respiration.
- (2) Where a test carried out under subregulation (1) of this regulation reveals the presence of any of the matters mentioned in that subregulation, the main contractor shall—
- (a) ensure that no person is permitted to enter the work area, unless that person—
- (i) is equipped with an efficient air supplied respirator and life-line attached to his body; and

- (ii) is attended by some other person;
- (b) provide an efficient mechanical extractor to disperse or expel any matter present in the air in or near the work; and
- (c) display warning signs on a rigid material not less than 450 mm by 750 mm bearing the words "WARNING—POISONOUS GASES PRESENT KEEP CLEAR" in letters 75 mm high on a yellow background with no other words.

(3) Where work to which the Act applies is to be carried out in a confined space and in the opinion of the Chief Inspector the nature of the work or the conditions existing are such as to require a qualified person to render assistance, the main contractor shall cause such qualified person to be in attendance for the duration of the work.

109. (1) Where on any work to which the Act applies an inspector is satisfied that in addition to the requirements in this Part other safety equipment or apparel is necessary for the safety of workmen or other persons he may direct the main contractor or sub-contractor to provide such additional safety equipment or apparel as he thinks is necessary for the occasion. General.

(2) A main contractor shall provide, in the foreman's office or other prominent position on a site, first aid boxes that conform to subregulation (3) of this regulation in the quantities as follows—

- (a) for any number of workmen between 20 and 50 ..... 1 box;
- (b) for every 50 workmen or part of 50 workmen in excess of 50 ..... 1 box.

(3) A first aid box shall contain—

- Six triangular bandages (not less than 1 m square).
- Six 75 mm x 5 m gauze type roller bandages.
- Six 50 mm x 5 m gauze type roller bandages.
- Six 25 mm x 5 m gauze type roller bandages.
- Twelve small individually wrapped sterile dressings.
- Twelve medium individually wrapped sterile dressings.
- Twelve large individually wrapped sterile dressings.
- One 40 g roll of cotton wool.
- One 30 g plain lint.
- One 1 m of 25 mm elastic adhesive strapping.
- Four packets of 24 adhesive plastic strips.
- One 50 ml Methylated spirits.
- One 100 ml of 1 in 1 000 antiseptic solution (Cetrimide or Cetavalon).
- One 50 ml sal volatile (Aromatic Ammonia Spirit).
- One eye bath or eye wash bottle.
- One 125 mm pair of surgical scissors.
- One 125 mm pair of surgical tweezers.
- One 175 mm plastic kidney dish.
- One packet of rustless safety pins.
- One 15 ml bottle of mercurochrome.
- Two packets of cotton buds.
- Two tins individually wrapped sterile Tulle Gras.
- One eye dust remover.

#### Division 5—Welding and Cutting.

110. A person shall not commence or cause or permit a person to commence welding or cutting operations on a site unless the area in which the welding or cutting operations are to be carried out conforms to these regulations. General.

111. A person shall not on a site carry out any welding or cutting operations unless— Conditions of work and workplace.

- (a) all regulators, tubing, blow-pipes, handpieces, cables, leads and ancillary equipment are—
  - (i) undamaged, free from all defects; and
  - (ii) of a type specified by the manufacturers of the welding equipment being used;
- (b) where practicable the area within a radius of 9 m of the welding or cutting operations is kept free of all combustible material, or, where it is not practicable to keep the area within that radius free of combustible material, any combustible material within that radius is either kept damp

- by watering or otherwise protected from sparks, slag and particles of hot metal by shielding those materials with guards made of a non-combustible material;
- (c) where the welding or cutting operations are being carried out in an elevated position, persons below that elevated position are effectively protected from sparks, slag and particles of hot metal;
- (d) all persons are effectively protected from heat or radiation by the provision of screens or shields.
- Gas cylinders. 112. A person shall not, on a site—
- (a) lift or lower a gas cylinder or cause or permit a person to lift or lower a gas cylinder unless the gas cylinder is contained in an approved type of box or cradle; or
- (b) use a gas cylinder unless it is secured in an upright position and protected from the weather.
- Electric welding. 113. A person shall not use an electric arc welding machine unless the electric arc welding machine and all ancillary equipment attached to and used in connection with the welding machine are used and maintained in accordance with sections 1, 2, 3, 4, 5 and Appendix A and B of A.S. CC 5-1965 Prevention of Electric Shock to Arc Welders.
- Duty to supply protective equipment. 114. A main contractor shall not cause or permit or suffer a person to carry out welding or cutting work unless he has provided that person with—
- (a) fire resistant gauntlets or gloves;
- (b) goggles, face shields or helmets that are fitted with filter lenses that comply with S.A.A. Specification Z 45-1967; and
- (c) where necessary, fire resistant aprons.
- Division 6.—Construction, Alteration or Repair of Lifts.
- Provision of power supply. 115. Where a lift sub-contractor carries out work to which the Act applies on a lift in a building or structure the main contractor shall provide the lift sub-contractor with an independent power supply.
- Entry by other persons. 116. (1) No person, other than a person authorized either by the main contractor or by a sub-contractor so to do, shall enter a lift motor room while electric power is connected to the lift circuit breaker.
- (2) A lift sub-contractor who carries out or intends to carry out work to which the Act applies on a lift shall—
- (a) place, in a conspicuous position adjacent to the entrance to the motor room, a notice on a white background bearing the word "DANGER" in letters 25 mm high and the words "ENTRY OF UNAUTHORIZED PERSONS PROHIBITED" in red letters 10 mm high; and
- (b) provide effective guards to all moving parts of any machinery in the motor room.
- Lighting and signalling. 117. Where a lift sub-contractor carries out any work in a lift shaft he shall provide—
- (a) adequate lighting to all work areas; and
- (b) an efficient auditory signalling system between the winch driver and the false car or permanent platform.
- Building in use. 118. Where work to which the Act applies is to be carried out in a lift shaft of a building that is in use, the main contractor shall not commence that work unless—
- (a) all openings between the lift shaft and the landing; and
- (b) the area in which the work is being carried out and any adjacent lift shaft that has a lift in operation,
- are enclosed by approved screens.
- Work in lift shafts. 119. A person shall not, in a lift shaft, carry out, or cause or permit or suffer a person to carry out any work to which the Act applies unless—
- (a) a 50 mm x 2.5 mm diameter wire mesh is fixed between the lift shaft and any adjacent lift shaft that has a lift in operation;
- (b) where work is being carried out at more than one level in that lift shaft, adequate overhead protection is provided;



- (c) all working places and the machine room have a safe and sufficient means of access and egress;
- (d) where the lift shaft is an express lift shaft and false cars or permanent cars are in use, an adjacent false car or permanent car platform is provided to give access to or egress from the express lift shaft; and
- (e) all openings of the lift shaft have fabricated steel guards that—
  - (i) are not less than 900 mm high;
  - (ii) have fenders at least 215 mm high; and
  - (iii) have the area between the fender and guard rail covered by a 75 mm x 50 mm x 4 mm diameter wire mesh.

120. (1) A person shall not use a permanent car as an installation aid unless and until there is issued in respect of that permanent car a Certificate for Machinery under the Inspection of Machinery Act 1921.<sup>1</sup>

Use of permanent cars as aids.

(2) Notwithstanding subregulation (1) of this regulation, a person shall not use a permanent car platform as an installation aid either under power or under manual operation unless the permanent car platform—

- (a) has approved safety gear that is kept in efficient working order;
- (b) is fully decked and fitted with a fender of not less than 100 mm at all edges;
- (c) has a guard rail 900 mm above the decking wherever the space between the platform and the shaft exceeds a distance of 200 mm;
- (d) is operated by a system of switches that—
  - (i) is either a pendant type switch or a fixed switch 900 mm from the platform floor;
  - (ii) is operated by a continuous pressure type button controlling two switches in separate circuits; and
  - (iii) has a manually re-set type stop switch that operates in the safety circuit;
- (e) is counterweighted to—
  - (i) suit the load rating; and
  - (ii) maintain the correct traction, within the prescribed design limits;
- (f) has electrical control settings that normally block or adjust to prevent the platform from exceeding a maximum speed of 40 m per minute irrespective of the platform load and the position of the platform in the shaft;
- (g) is protected from the moving counterweight of the lift by a 40 mm x 40 mm x 2.65 mm wire mesh fitted to the back and over the top of the platform;
- (h) has its load rating displayed on the car platform;
- (i) has compensating ropes or chains;
- (j) has an overspeed governor that is set so that the platform cannot exceed a speed exceeding 56 m per minute;
- (k) has a governor rope connected to the safety gear; and
- (l) has a machine brake that is clean, connected and efficient.

(3) A person shall not use a permanent car platform as an installation aid unless all pit buffers are installed in the lift shaft and, where the pit buffers are of a piston type, they are filled with oil.

121. A person shall not use a false car and permanent car platform in a lift shaft unless—

Use of permanent and false cars in same shaft.

- (a) where a false car is used below a permanent car platform a fully decked platform is erected between the cars; and
- (b) in any other case the cars are operated at a distance that exceeds—
  - (i) 12 m in the case of an express shaft; or
  - (ii) four floor levels in any other case.

122. A person shall not use a false car as an aid in installation in a lift shaft unless the false car—

Use of false cars as platforms.

- (a) has a supporting frame of steel or aluminium alloy;
- (b) has a fully decked platform capable of supporting a load of 275 kg safely;

<sup>1</sup> Now Machinery Safety Act 1974.

- (c) is fitted with an instantaneous self-activated clamping device that is capable of—
  - (i) locking the platform to the guide runners; and
  - (ii) being released into an “off” position and holding the “off” position only when held in the “off” position by the operator on the platform;
- (d) has fender boards not less than 100 mm high fitted to all edges;
- (e) has a guard rail not less than 900 mm high that is fitted to every edge of the platform that would otherwise open on a space more than 200 mm away from a shaft wall;
- (f) is attached to the hoist rope either by a wedge socket or by a thimble and an approved terminal connection;
- (g) can be supported in a stationary position—
  - (i) by a clamping device; and
  - (ii) either a hoist rope or an adequately secured flexible steel wire sling of equivalent strength;
- (h) has a maximum speed that does not exceed 15 m per minute; and
- (i) has, fixed in a prominent position, a notice in black letters 75 mm high on a yellow background indicating the maximum safe working load of 275 kg.

Winches.

123. (1) A person shall not use a winch for doing any work to which the Act applies in or on a lift unless the winch—
- (a) is properly secured in position; and
  - (b) is an approved drive-updrive down type that does not incorporate any form of declutching that allows free fall or is an approved manually operated type.

Hoist driver.

- (2) A person shall not drive or operate a winch for the purpose of carrying out any work in connection with a lift or a lift shaft unless he holds a current Hoist Driver's Certificate issued under the Machinery Safety Act 1974.

#### Division 7.—Formwork and Falsework.

Components used in formwork and falsework.  
Amended by G.G. 5/3/76, p. 691.

124. (1) A person shall not use a component, fitting or device in the construction of formwork or falsework unless the component, fitting or device—
- (a) conforms to—
    - (i) an approved type;
    - (ii) Rules 3.4, 3.5 and 3.6 of A.S. 1509-1974 Standards Association of Australia Formwork code; or
    - (iii) these regulations; and
  - (b) is set up and used—
    - (i) in terms of the approval;
    - (ii) in accordance with the manufacturer's directions; or
    - (iii) in accordance with these regulations.

(2) A person shall not use tubular steel or tubular steel fittings in formwork or falsework unless the tubular steel fittings comply with regulations 20 to 24.

(3) A person shall not use a component in formwork or falsework unless he has inspected the component before use.

General erection of formwork.

125. (1) A person shall not use or construct formwork or falsework in work to which the Act applies unless—
- (a) the formwork or falsework is so designed, erected, supported, braced and maintained that it supports safely all vertical or lateral loads and withstands any force that may be applied to the loads until the loads can be supported by the concrete structure;
  - (b) vertical or lateral loads are carried to the ground by the falsework and by the in-place construction that has attained adequate strength for the purpose;
  - (c) the formwork or falsework is braced by lateral or diagonal bracing in vertical or horizontal planes where required and to the extent necessary to ensure the stability of the whole framework and to prevent buckling of individual members;

- (d) the formwork or falsework is supported by sole plates, spread footings or pile footings with sufficient capacity to carry the maximum loads intended to be imposed on the formwork or falsework;
  - (e) the sole plates used in the formwork or falsework are—
    - (i) continuous;
    - (ii) bedded evenly over their whole bearing; and
    - (iii) borne on undisturbed or compacted soil;
  - (f) the falsework is so designed as to allow vertical adjustments to be made to facilitate erection and stripping of the formwork.
- (2) Falsework may incorporate screwjacks at the top of and base of verticals of tubular shores and frame type shores.
- (3) A person shall not use a wedge—
- (a) at both ends of a shore; or
  - (b) in a manner that allows the wedge to move.
- (4) Where—
- (a) a “U”-head and a proprietary brand steel shore are used to support timber bearers; and
  - (b) the width of the bearer is less than the width of the “U”-head,
- the person constructing the formwork or falsework shall centre the bearer over the shore.
- (5) A person shall—
- (a) carry out stripping of formwork or falsework in a systematic manner and so as to do minimum damage to the components; and
  - (b) upon completion of the work, stack the components of the formwork or falsework so that there is no obstruction either to accessways or to work areas.

126. The Chief Inspector may, by notice in writing, require a main contractor to furnish him with the detailed design drawings and load calculations of any proposed falsework certified by a qualified structural engineer. Certified drawings.

#### Division 8.—Excavation Work and Trenching Work.

127. A person shall not commence any excavation work if the excavation—
- (a) is likely to endanger his own safety or the safety of other persons in the vicinity of the excavation; or
  - (b) is likely to cause the collapse of any building or structure in the vicinity of the excavation,
- unless adequate precautions have been taken to prevent any of those events from occurring. Excavations near buildings.

128. (1) A person shall not place a hoisting appliance, power driven equipment or other load in or near an excavation unless the sides of the excavation have been adequately supported to prevent the collapse of the sides of the excavation. Hoisting appliances and equipment.

(2) A person shall not place overburden or surcharge in a place that is less distant from an excavation than one-third the depth of the excavation.

129. (1) Where in any work to which the Act applies a dangerous condition is likely to arise to a workman because of excavation work, the main contractor shall—
- (a) erect, as close as possible to any likely cause of the danger, suitable barriers to a height of not less than 900 mm between the workman and the likely cause of the danger; and
  - (b) maintain sufficient and safe means of access—
    - (i) into the excavation;
    - (ii) out of the excavation; and
    - (iii) across the excavation.
- (2) A workman shall not do any work in an excavation unless there is at least one other workman in the immediate vicinity of the excavation. Safety conditions in excavation work.

Shoring of excavation work.

130. The main contractor shall ensure that—
- (a) every face of any excavation that exceeds a depth of 1.5 m is supported or contained by shoring unless—
    - (i) the face is cut back to a safe slope;
    - (ii) the material in the face has good standing quality under all anticipated conditions of work and weather; or
    - (iii) by reason of the nature of the work and the position of the persons in the vicinity of the work there is no danger to those persons;
  - (b) the shoring of the excavation is braced as the excavation progresses, and, where a mechanical digger is used the shoring is kept as close as practicable to the digger; and
  - (c) the shoring extends at least 200 mm above the surrounding ground level or a similar protection is provided at the edges of the excavation by a fender board.

Shoring of trenches.

131. A person shall not carry out any excavation work in a trench unless—
- (a) the timber shoring of the trenches is comprised of sheeting boards secured in position by a system of walings and struts;
  - (b) the sheeting boards—
    - (i) are vertical;
    - (ii) are either closely boarded in the case of an excavation in sandy soil or boarded at maximum intervals not exceeding 1.25 m in the case of cohesive soils; and
    - (iii) have cross sectional dimensions of at least 235 mm by 38 mm;
  - (c) the walings are—
    - (i) parallel to the bottom of the trench;
    - (ii) supported by cleats attached to the sheeting boards;
    - (iii) positioned in the trench so that one waling is not more than 500 mm below the surrounding ground level and another waling not more than 500 mm above the bottom of the excavation, but where equal support is given by sheeting driven into the excavation the second waling may be omitted; and
    - (iv) placed with the smaller dimensions against the sheeting boards;
  - (d) the struts—
    - (i) are horizontal and at right angles to the walings; and
    - (ii) have cleats that extend over the walings.

Specifications of shoring.

132. (1) A person shall not enter a trench or cause or permit or suffer a person to enter a trench for the purpose of carrying out any work to which the Act applies where—
- (a) the trench has a depth that does not exceed 6 m unless the shoring in the trench conforms to the requirements prescribed in the table to this regulation; or
  - (b) the trench has a depth that exceeds 6 m unless the shoring conforms to the specifications and arrangements approved by a qualified civil engineer.

TABLE TO REGULATION 132 (1)

Depth of Trench Metres	Minimum Dimension Millimetres	Walings		Struts			
		Vertical Spacing Metres		Minimum Dimension Millimetres		Horizontal Spacing Metres	
		Above Highest Water Table	Below Highest Water Table	Width of Trench up to 2 metres	Width of Trench 2 metres-4 metres	Above Highest Water Table	Below Highest Water Table
1.5-3	150 x 100	1.25	1	100 x 100	125 x 125	2.50	1.25
3-4.5	200 x 100			100 x 100	125 x 125		
4.5-6	200 x 200			125 x 125	150 x 150		

- Notes: 1. For sandy soil, sheeting must be close boarded.  
 2. For cohesive soils, maximum sheeting spacing—1.25 m.  
 3. Minimum sheeting size—235 mm x 38 mm.  
 4. Use standard grade karri or timber of equal strength.

(2) A person shall not use a proprietary brand trench jack in a trench unless the trench jack—

- (a) is of an approved design; and
- (b) when used, provides support that is not less than the support provided by the shoring prescribed in this Division.

#### Division 9.—Demolition Work.

133. A main contractor shall not commence construction work that involves the demolition of a building or structure unless and until he has— Safety precautions.

- (a) complied with regulations 79 and 92 except where—
  - (i) the demolition work involves work that is carried on wholly inside a building or structure; and
  - (ii) the debris from the demolition work is prevented from falling or rebounding outside the building or structure;
- (b) taken all practicable steps to protect persons from injury and property from damage by any or all of the following—
  - (i) leakage or accumulation of gas or vapour;
  - (ii) flooding of water mains, drains or sewers;
  - (iii) fire or explosion;
- (c) where necessary, installed a temporary electrical supply that complies with the S.A.A. Wiring Rules;
- (d) closed off access to the site except to provide for the passage of workmen or the conveyance of material or equipment; and
- (e) removed or boarded up all glass either fixed or movable in the building or structure.

134. Where a main contractor or sub-contractor intends to carry out demolition work on a part of a building or structure that— Cantilevered catch platforms.

- (a) exceeds 8 m in height; and
- (b) is adjacent either to a public place or to a lower level building that is in use,

the main contractor or sub-contractor as the case may be shall, in addition to complying with regulation 133, erect on the site cantilevered catch platforms that conform to regulation 135 or medium duty scaffolding.

135. Cantilevered catch platforms that are used in demolition work— Specifications of cantilevered catch platforms.

- (a) shall be positioned so that they are not more than two storeys below the level of the work;
- (b) shall be placed along the outside of external walls of the building or structure;
- (c) shall be capable of supporting a load of not less than 365 kg/m<sup>2</sup>;
- (d) shall be not less than 1.5 m in width, measured horizontally from the wall of the building or structure;
- (e) shall be set at an upwards inclination from the inner to the outer edge of not less than 1 in 10;
- (f) shall be supported by outriggers on edge that—
  - (i) are of hardwood with dimensions of not less than 250 mm by 75 mm or other material with the same strength;
  - (ii) are spaced at intervals of not more than 3 m;
  - (iii) have an inboard length of at least 3 m;
  - (iv) are secured to the floor joist or concrete floors to give a safety factor of 3; and
  - (v) are secured to prevent lateral movement;
- (g) shall have planks—
  - (i) that are not less than 50 mm thick; and
  - (ii) that form a closely boarded platform that abuts on the building or structure;
- (h) shall have fender boards on the outer edges.

- Scaffolding in demolition work.
136. A person shall not carry out any demolition work unless the scaffolding used in that demolition work—
- (a) conforms to the requirements for medium duty scaffolding in regulations 26 and 27;
  - (b) is erected to the full height of the building or structure;
  - (c) has a closely boarded platform with a minimum width of 900 mm that abuts on the face of the building or structure at the working level; and
  - (d) has a fender board not less than 900 mm high fitted on the outer edge and on the ends of the working platform.
- Scaffolding to be maintained in position.
137. The main contractor or sub-contractor as the case may be shall ensure—
- (a) that scaffolding is maintained in position and in an effective state up to the working level of the scaffolding during the whole of the period that demolition work is being carried out; and
  - (b) that the scaffolding is progressively dismantled so that the unsupported part of the scaffolding does not exceed by more than 4 m the height of the last row of ties that secure the scaffolding to the building or structure.
- Precautions in demolition work.
138. Every person performing demolition work on a building or structure—
- (a) shall execute the work in a systematic manner commencing at the roof and continuing downwards storey by storey;
  - (b) shall not drop or accumulate debris on a floor beyond the safe capacity of the floor;
  - (c) shall, before leaving the work for an interval of time, secure by shoring or other means any unsafe part of the building or structure;
  - (d) shall ensure that any structural load bearing member that contributes to the stability of the building or structure is not cut or removed until the part of the building or structure the member supports is demolished;
  - (e) shall not allow debris to accumulate and cause danger by the deflection of other debris on the accumulation;
  - (f) shall, where working on external walls, progressively demolish intersecting walls by raking back, to form an angle of not more than 45 degrees from a point at the intersection of the internal wall and the external wall and the horizontal from that point;
  - (g) shall demolish an external wall abutting on a public place only with hand held gear;
  - (h) shall prevent dust from becoming airborne either by dampening down debris or by other means;
  - (i) shall maintain, in a safe condition, all stairways, landings or other facilities that are used for access or egress until the part of the building or structure serviced by the stairway, landing or other facility is demolished.
- Demolition work to be as prescribed.
139. (1) A person shall not carry out demolition work unless it is carried out in a manner that is—
- (a) prescribed by these regulations; or
  - (b) approved by the Chief Inspector.
- (2) A person shall not use explosives in demolition work without approval.
- (3) A person shall not carry out demolition work by the use of explosives unless he complies with Part X of these regulations.
- Removal of debris.
140. (1) A person shall remove the debris from demolition work—
- (a) through an opening in the floor of the building or structure if—
    - (i) the area of the opening does not exceed 25 per centum of the floor area unless another opening is approved; and
    - (ii) the opening and each opening lower than the opening that first receives the debris are fitted with guard rails that conform to regulation 54 fixed in position 2 m from the edge of the opening;
  - (b) by lowering by a hoisting appliance; or
  - (c) by chutes that—
    - (i) are completely enclosed;

- (ii) discharge either into a disposal hopper or into an area that is completely enclosed by a hoarding not less than 2 m in height; and
- (iii) have warning notices that are readily visible placed at the discharge end.

(2) Where the cutting of an opening in a floor makes the floor or any part of the floor unsafe the main contractor or the sub-contractor as the case may be shall ensure that the floor is secured by shoring.

141. (1) Subject to subregulation (2) of this regulation, a person shall not execute any demolition work on a building or structure by means of— Use of appliances.

- (a) a swinging weight, bulldozer, power shovel or clamshell bucket; or
- (b) any mechanical appliance or device,

to cause either a partial or a total collapse of a building or structure.

(2) Where the height of the building or structure does not exceed 22 m a person may with written approval and subject to the conditions of the approval, execute demolition work by means of the appliances in paragraphs (a) and (b) of subregulation (1) of this regulation.

(3) Where a person executes demolition work under subregulation (2) of this regulation he shall, during the whole period of the work—

- (a) maintain a demolition zone that has an area, in plan view that contains a distance to its perimeter not less than one and one-half times the height of the building or structure; and
- (b) prevent persons from entering or remaining in that zone unless they have a good and sufficient reason to enter or remain thereon.

142. Where the stability of walls or floors in a building or structure is affected because of fire or earthquakes or because of any other reason the walls and floors shall be supported by shoring or ties. Unstable structures.

143. (1) Where the demolition work consists of demolishing a chimney either by blasting with explosives or by felling, the main contractor or the sub-contractor as the case may be shall— Chimney stacks.

- (a) establish an area clear of any building and forming in plan view a section from the base of the chimney stack, having a radius equal to one and one-half times the height of the chimney stack, with an included angle of 120 degrees, measured 60 degrees on each side of the line of the intended fall; and
- (b) place a barricade on the perimeter of the area established under paragraph (a) of this subregulation.

(2) Where a chimney stack is demolished by progressive demolition from the top a person shall—

- (a) execute the work from scaffolding that conforms to the requirements of regulations 26 and 27 for medium duty scaffolding;
- (b) drop the debris only through the chimney;
- (c) remove the debris regularly; and
- (d) cease demolition while the debris is being removed.

#### PART VIII.—ROOFS SHEATHED WITH ASBESTOS CEMENT SHEETS OR WITH BRITTLE ROOF MATERIALS.

144. In this Part, unless the contrary intention appears—

“brittle roof material” means sheeting material of glass, plastic, acrylic or other similar synthetic moulded or fabricated material used either— Interpretation.

- (a) to sheath a roof; or
- (b) in a roof,

that will in the opinion of the Chief Inspector endanger or be likely to endanger a person standing on the roof;

“large section sheets” means corrugated asbestos cement sheets of a material of not less than 6 mm in thickness, having corrugations 47 mm and over in depth, the pitch of the corrugations being more than 76 mm but not more than 146 mm, measured from centre to centre of adjacent crests or troughs;

“longitudinal wires” means the safety mesh wires parallel to the corrugations of the roof sheathing;

“safety mesh” means a mesh-work of galvanized steel wires of size and arrangement specified in these regulations;

“small section sheets” means corrugated asbestos cement sheets of a material of not less than 5 mm in thickness, having corrugations less than 47 mm in depth, the pitch of the corrugations being 76 mm or less, measured from centre to centre of adjacent crests or troughs;

“transverse wires” means the safety mesh wires at right angles to the corrugations of the roof sheathing.

Distance between supports.

145. A person shall place purlins, or other immediate supports, for corrugated asbestos cement roof sheathing at spaces, when measured from centre to centre—

- (a) not more than 1.265 m apart, measured in the direction of the corrugations, where supporting large section sheets;
- (b) not more than 915 mm apart, measured in the direction of the corrugations, where supporting small section sheets; or
- (c) not more than the maximum distance approved in writing by the Chief Inspector, where supporting sheets differing in section from those mentioned in paragraphs (a) and (b) of this regulation.

Asbestos roofs.

146. (1) Subject to subregulations (2) and (3) of this regulation, a person shall not place lay or fix, or cause to be placed, laid or fixed upon any roof structure, or part of any roof structure, a roof sheathing of asbestos cement, unless safety mesh has first been securely fixed to the roof structure, in the manner prescribed by these regulations.

(2) The provisions of subregulation (1) of this regulation do not apply to a roof—

- (a) of which the members immediately supporting corrugated asbestos cement sheathing are spaced—
  - (i) not more than 460 mm apart measured from centre to centre, for small section sheets; or
  - (ii) not more than 610 mm apart measured from centre to centre, for large section sheets;
- (b) of a single storey dwelling house or of one of its outbuildings.

(3) Subregulation (1) of this regulation does not apply where safety mesh, if used, would be likely to be affected by corrosive agencies, and in such a case the roof members immediately supporting the corrugated asbestos cement sheathing shall be spaced as prescribed by paragraph (a) of subregulation (2) of this regulation.

Specification of safety mesh.

147. (1) A person shall not use safety mesh in a roof unless the safety mesh is so constructed that—

- (a) it is made entirely of galvanized wire with a minimum diameter of 3.25 mm;
- (b) the size of each mesh is not greater than 300 mm by 300 mm;
- (c) the wires forming each corner of each mesh are welded, or otherwise affixed one to the other, so that there is no movement at their junction; and
- (d) it conforms to such standards as may be specially approved in writing.

(2) Notwithstanding the provisions of subregulation (1) of this regulation, a person shall be deemed not to have complied with these regulations, unless a complete specification and such specimens of the mesh, as may be required from him in writing for examination by the Chief Inspector, have been submitted to and approved by him.



148. (1) In this regulation—  
 “anchorages” includes purlins;  
 “staples” means galvanised steel staples 25 mm by 3.25 mm.
- (2) A person shall fix safety mesh to the anchorages—  
 (a) subject to subregulation (3) of this regulation, by taking the longitudinal wires over the top of, bending them down and fixing them to the side of every anchorage with staples; or  
 (b) subject to subregulation (3) of this regulation, by fixing the longitudinal wires to the tops of the anchorages with staples; or  
 (c) by passing the longitudinal wires once completely around every anchorage and twisting the tail of each wire twice tightly around the main portion of the same wire.
- (3) A person fixing safety mesh shall drive a staple in respect of each longitudinal wire of the safety mesh into each anchorage—  
 (a) in such a position that a transverse wire is immediately behind the staple and is between the staple and the end of the longitudinal wire; or  
 (b) so that the longitudinal wire, once stapled, is bent back, and again stapled, over the main portion of the same wire.
- (4) A person shall generally fix safety mesh in such a manner that—  
 (a) it rests upon each of the purlins, or battens;  
 (b) it is free from perceptible sag;  
 (c) it is immediately beneath the roof sheathing;  
 (d) the transverse wires are located above the longitudinal wires;  
 (e) where a break of continuity in the longitudinal wires occurs, those wires are effectively joined so as to preserve the same measure of safety as that afforded by continuous wires; and  
 (f) the longitudinal wires at the adjoining or overlapping edges of adjacent strips of safety mesh are strongly fastened together at intervals not greater than 1 m.
149. Where asbestos cement box-gutter sections are used, a person shall space the gutter supports not more than 760 mm apart, measured from centre to centre, or fix a suitable gutter board immediately under, and supporting, the box-gutter sections.
150. (1) Subject to subregulation (2) of this regulation a person shall not place, lay or fix or cause to be placed, laid or fixed upon any roof structure a roof sheathing of brittle roof material unless there has first been fixed to that roof structure a safety mesh that conforms to regulations 147 and 148.
- (2) Where the brittle roof material is domed or otherwise raised above the support purlins, and the provisions of subregulation (1) of this regulation cannot be complied with, the owner shall display a notice in such a manner as to be clearly visible to all persons who may approach the area.
- (3) The notice mentioned in subregulation (2) of this regulation shall—  
 (a) have minimum dimensions of 230 mm in width and 75 mm in height;  
 (b) have black lettering at least 25 mm in height on a yellow background;  
 (c) be finished in vitreous enamel, or other material approved; and  
 (d) bear the words—  
 “WARNING—KEEP OFF—BRITTLE ROOF”.
- (4) Notwithstanding the provisions of this regulation, the Chief Inspector may approve of any other means to be adopted when fixing brittle roof material.
151. (1) Where no means of access is provided to the underside of a roof sheathed with asbestos or brittle roof material, the owner, main contractor or other person in charge, shall, if required by an inspector, remove portion of the roof sheathing to allow an inspection to be made to ensure that the provisions of this Part are complied with.

Fixing of safety mesh.

Asbestos box-gutters.

Roofs of brittle roof materials.

Inspection.

(2) Where upon inspection made pursuant to this regulation, it appears to an inspector that the provisions of this Part have not been complied with, he may, by notice in writing, order such things to be done as may, in his opinion, be necessary to bring about compliance with that regulation.

(3) Where, upon any inspection made pursuant to this regulation, it appears to an inspector that the safety mesh has, or its fastenings or supports have been reduced in strength, by corrosive or other action, to less than 90 per cent of the strength prescribed by regulation 147, the inspector shall give to the owner of the building so affected notice in writing to renew the mesh, fastenings or supports (as the case may require) in such a manner as the notice may direct.

## PART IX.—EXPLOSIVE POWERED TOOLS.

### Division 1.—General.

- Interpretation. 152. (1) In this part, unless the contrary intention appears—
- “authorized person” means a person registered with the Chief Inspector as a manufacturer, repairer or seller of, or dealer in, tools, pins and charges, and includes a person in the employ of a person so registered, while acting under his direct supervision;
- “defect” means any defect that may impair or affect the safe and normal operation of a tool;
- “direct acting tool” means a tool in which the driving force on the projectile comes directly from the compressed gases from the explosive charge;
- “explosive powered tool operator” means a person who holds a certificate of competency as an explosive powered tool operator under Part XII of these regulations;
- “projectile” means stud, pin, dowel, screw, rivet, spike, nail or other object driven, against, into or through any substance by means of a tool;
- “repair” includes renovate, modify, alter or adjust, or attempt to do any of those things;
- “tool” means a tool whereby a projectile may be driven against, into or through any substance by means of an explosive charge and includes every attachment to, and accessory of, the tool and every device used, or adapted or intended to be used with the tool, but does not include a firearm within the meaning of the Firearms Act 1973, or a side wall coring gun used in exploratory bore hole work.
- (2) For the purpose of these regulations a person is deemed to use a tool if he loads, unloads or discharges it or attempts to do any of those things.
- Explosive powered tool operators to use tools. 153. (1) Subject to subregulation (2) of this regulation every person who—
- (a) not being an explosive powered tool operator, uses a direct acting tool; or
- (b) employs or permits some other person, not being an explosive powered tool operator or, being physically incapacitated, to use a direct acting tool,
- commits an offence.
- (2) Nothing in subregulation (1) of this regulation applies to a person who, while receiving training to become an explosive powered tool operator, uses a direct acting tool under the immediate and personal supervision of an explosive powered tool operator.
- General requirements of tools and projectiles. 154. A person shall not sell, offer for sale, hire out, lend, use, or cause to be used, any tool, unless it—
- (a) corresponds, in all respects, with an approved specimen;
- (b) has a notice permanently engraved or embossed upon it, in a conspicuous position, so as to be clearly legible at all times, reading as follows—
- DO NOT REMOVE THIS TOOL FROM THE WORK SURFACE  
FOR AT LEAST 10 SECONDS AFTER IT HAS FAILED  
TO FIRE. ;**
- (c) has permanently engraved or embossed upon it a clearly legible serial number and model identification by which it may be readily identified;

- (d) has a protective shield or device attached to its muzzle end in such a manner—
- (i) as effectually to arrest the escape of projectiles and other objects and particles liberated by the discharge of the tool; and
  - (ii) in the case of a direct acting tool, that the outer edge is not at any point closer to the centre of the barrel than a distance of 50 mm, except where the tool is to be used in the circumstances mentioned in subregulation (2) of regulation 170.

155. (1) Every person applying for approval of a tool shall submit to the Chief Inspector— Applications for approval.

- (a) a specimen of the tool, to enable the determination, by examination, and tests, of its functioning and characteristics;
- (b) such samples of the materials used in the construction of the tool as the Chief Inspector may, from time to time, require;
- (c) fully dimensioned drawings and specifications of the tool such as will establish its pattern, detailed construction and nature; and
- (d) such further information in writing as may be required by the Chief Inspector for any of the purposes of this regulation.

(2) Any specimen tool, samples of materials, drawing, specifications and other written information submitted in accordance with this regulation may be retained by the Chief Inspector.

(3) Every person applying for approval of a tool shall satisfy the Chief Inspector that the tool—

- (a) will not be discharged if dropped on a concrete or steel surface from a height of 3 m;
- (b) cannot be accidentally discharged while being handled; and
- (c) in the case of a direct acting tool, cannot be discharged—
  - (i) by an operator, unless a force of not less than 110 N is applied by the operator to the springs of the breech and firing mechanism; or
  - (ii) while the axis of the barrel or barrel extension deviates by more than 7 degrees from a right angle formed by the barrel and the surface into which a projectile is to be fired.

(4) Where the Chief Inspector is satisfied that any specimen of a tool is so manufactured as to be in accordance with these regulations, he shall grant his approval in writing, and no modification, addition or alteration shall be made to the tool without his approval.

(5) Every person who falsely represents that a tool corresponds with a specimen approved under these regulations, whether by marking it or in any other manner, commits an offence.

(6) The owner shall, if required by the Chief Inspector, submit any tool to him for examination.

156. (1) A person shall not manufacture or sell for use in a tool—

- (a) a smooth shanked projectile, unless that projectile can be bent through an angle of 60 degrees; or
- (b) a knurled shanked projectile, unless that projectile can be bent through an angle of 30 degrees,

Forbidden manufacture and use of projectiles.

where in the test in each case the projectile is bent about a pin with a diameter equal to the diameter of the shank of the projectile.

(2) A person shall not—

- (a) manufacture;
- (b) sell or deal in; or
- (c) use with a tool,

any projectile or explosive charge that is of such a standard or quality that, when used correctly and in accordance with the specifications of the manufacturer of the tool, could cause injury to any person.

Strength of charges to be indicated.

157. A person shall not sell, offer for sale, or have in his possession for sale, any explosive charge for use in a tool, unless the case containing the charge is marked either at the top or at the bottom, with a colour to indicate its relative strength, in accordance with the table to this regulation.

THE TABLE.

Brown—Minimum strength.  
 Green—Weak.  
 Yellow—Medium strength.  
 Red—Strong.  
 Purple—Very strong.  
 White—Especially strong.  
 Black—Maximum strength.

Registration of tools. Amended by G.G. 5/3/76, p. 691.  
 Notification of ownership.

158. (1) The Chief Inspector shall cause a register to be kept in which shall be entered the type and serial number of every tool in use and the name and address of the owner.

(2) Every person who sells or transfers ownership of a tool shall, within forty-eight hours after the sale or transfer, notify the Chief Inspector by notice in writing of that happening, setting out in the notice the type and serial number of the tool and the name and address of the purchaser or transferee.

(3) Every purchaser of a tool shall, within forty-eight hours of his obtaining possession of it, notify the Chief Inspector in writing of the type and serial number of the tool and of his name and address.

(4) A document signed by the Chief Inspector stating that a person is registered under this regulation as the owner of any tool is *prima facie* evidence that that person is the owner of the tool.

(5) In this regulation "owner" means legal owner.

(6) Every owner of a tool that has been lost or stolen shall notify the Chief Inspector within forty-eight hours and shall notify the type and serial number of the tool.

Inspection.

159. (1) The owner shall cause every tool in his possession to be completely overhauled, by an authorized person, at least once in every period of twelve months.

(2) The owner shall cause every direct acting tool in his possession—

- (a) to be inspected for defects by a licensed operator, immediately before its first use on any day; and
- (b) to be dismantled and examined for defects by a licensed operator before being used again, after every 60 hours use in the aggregate.

(3) The owner shall not use a tool or cause it to be used unless—

- (a) it has been inspected, examined and overhauled pursuant to this regulation;
- (b) it is free from any defect that has been revealed on any inspection, examination or overhaul, whether pursuant to this regulation or not; and
- (c) after an overhaul, carried out pursuant to subregulation (1) of this regulation, the authorized person who carried out the overhaul issues a certificate, in the form of Form 5, that the tool is free from defects.

(Form 5.)

(4) An inspector may declare any tool unsafe for use and the owner shall thereupon cause that tool to be removed from service until it has been repaired and a certificate in the form of Form 5 has been issued, by an authorized person, in respect of the tool.

(Form 5.)

Repair.

160. (1) A person other than an authorized person shall not repair a tool; but an explosive powered tool operator or other person who, under the immediate supervision and control of an explosive powered tool operator, is being trained as an explosive powered tool operator is not deemed to repair a tool by reason only of his making, or attempting to make, such minor adjustments as are incidental to its ordinary operation.

(2) A person shall not—

- (a) employ, cause or permit any person, other than an authorized person, to repair a tool;

- (b) knowing that a tool has been repaired by a person other than an authorized person, use or employ, cause or permit any person to use, that tool unless, since being so repaired, it has been overhauled by an authorized person; or
- (c) at any time repair a tool in such a way that, when repaired, it does not correspond with a specimen tool approved under these regulations.

161. (1) The owner of a tool shall provide for every person using, or assisting in the use of, the tool— Protective devices.

- (a) a device or devices such as will mitigate against the possibility of damage to the hearing of that person; and
- (b) such spectacles, complying with with the S.A.A. Specification A.S. Z7 Industrial Eye Protectors, or such other device or devices as will protect the eyes of that person from injury.

(2) In complying with the provisions of subregulation (1) of this regulation, an owner shall supply such devices only as are of a non-absorbent material and are thoroughly cleansed.

(3) Every person for whose use a device has been provided pursuant to this regulation shall use it when using, or assisting in the use of, a tool.

#### Division 2.—Use of Tools.

162. (1) No person shall use a tool unless a notice or notices are displayed in such a manner as to be clearly legible by all persons who are at, or near, the place where the tool is being used and bearing the words— Notice.

WARNING—EXPLOSIVE POWERED TOOL IN USE.  
KEEP CLEAR.

(2) Every notice mentioned in subregulation (1) of this regulation shall be displayed on a rigid rectangular board measuring not less than 750 mm in width and 450 mm in height; the wording shall be in black poster type lettering of not less than 75 mm in height, on a yellow background, and no other matter shall be included on the board.

163. (1) A person shall not use a tool, projectile or explosive charge that is not approved under these regulations. Forbidden equipment.

(2) A person knowing that a tool has any defect, shall not use or employ, or cause or permit any person to use, that tool.

164. A person shall not use in or with a tool any projectile, explosive charge, breech plug, barrel extension or adaptor that is not of a type suited to the particular tool and to the purpose for which the tool is being used; and a person shall not use a tool for any purpose other than that for which it is made or adapted. Incorrect fitting of equipment.

165. (1) Where there appears on a tool, on the container of a tool, or in any printed matter supplied with a tool, any instruction, advice or recommendation, not inconsistent with these regulations, as to the safe use of the tool or the use therewith, for reasons of safety, of any substance or thing, that tool, substance or thing shall be used in accordance with that instruction, advice or recommendation. Compliance with maker's instructions.

(2) Nothing in this regulation requires the use of any named brand or make of any substance or thing.

166. A person shall not use a barrel extension on a tool unless there is attached to the extension a protective shield or device such as is mentioned in paragraph (d) of regulation 154. Barrel extensions.

167. (1) A person shall not load a tool with any explosive charge that he knows, or would by reasonable testing know, to be— Forbidden use of charges.

- (a) in excess of that necessary for the purpose for which the tool is to be used; or
- (b) of such strength as will cause the whole of the projectile to pass through the substance on which the tool is to be used.

- (2) The provisions of paragraph (b) of subregulation (1) of this regulation do not apply where the substance is backed by a material that is capable of fully absorbing the energy of the projectile.
- Use of tools in dangerous atmosphere. 168. (1) A person shall not use a tool in the presence of any explosive or inflammable gas, dust or vapour, in compressed air or in any place where the explosive charge may be unintentionally exploded or be rendered dangerous by the presence of heat.
- (2) A person shall not use a tool on any roof unless the area beneath the operator is cleared and kept cleared for a distance of 6 m in every direction from the place where the operator is working.
- Handling tools. 169. Every person shall, at all times, while using, carrying or handling a loaded tool—
- keep every part of his body clear of the muzzle end of the tool;
  - keep the muzzle end of the tool pointed away from any other person; and
  - exercise the utmost care to avoid injury to himself and others.
- Discharging tools. 170. (1) A person shall not discharge a tool unless—
- he is in a safe, well-balanced position that will prevent tilting or misalignment of the tool at the time of firing; and
  - the tool is so placed upon the substance into which a projectile is to be driven that the shield or device mentioned in paragraph (d) of regulation 154 will effectively arrest the escape of the projectile and any other objects or any particles liberated by the firing of the tool.
- (2) A person shall not use a tool that is fitted with an interchangeable or adjustable shield or device such as is mentioned in paragraph (d) of regulation 154, in such a manner that the distance between any part of the outer edge of that shield or device and the centre of the barrel is less than 50 mm, except where the escape of a projectile into any area outside the shield but within a radius of less than 50 mm from the centre of the barrel, would effectively be arrested by other surrounding material.
- Free fire prohibited. 171. A person shall not intentionally or negligently fire a tool in such a manner as to cause a projectile to fly free.
- Forbidden firing. 172. (1) A person shall not use a tool for driving a projectile into—
- high tensile steel, steel hardened by heat treatment, cast iron or any other substance of a hardness that a projectile is not designed to penetrate;
  - tiles, terracotta, glazed brick, glass, marble, granite, thin slate or any other substance that is readily shattered; or
  - concrete or reinforced concrete, where any initial trial has shown that the aggregate is of such hardness, or the reinforcing is so positioned, that the use of the tool is unsafe.
- (2) A person shall not use a tool to drive a projectile—
- so close to the edge of any substance, or to any hole in the substance, as either to risk cracking or breaking the substance or to risk the escape of the projectile from the substance;
  - within 15 mm of the edge of exposed steel; or
  - into any brick, concrete or similar substance that is within 75 mm of an edge of a structure of which it forms a part.
- Removal of foreign matter. 173. A person using a tool shall, after each firing, carefully examine it and remove from it any pieces of projectile or explosive charge and any other foreign matter that may be present.
- Procedure on mechanical failure of tool. 174. Where a person attempts to use a tool on a surface and the charge fails to explode, he shall continue to hold it in the firing position, for at least ten seconds; and, if after that period the charge has not exploded, he shall unload the tool or place it in such a position as will eliminate the possibility of a person being injured in the event of the charge subsequently exploding.

## Division 3.—Care and Storage of Tools and Explosive Charges.

175. (1) The owner of a tool shall keep it, or cause it to be kept, in a securely locked container at all times when it is not required for use, inspection, repair or other essential purpose; and a person shall not take or keep a tool out of its container unless the tool is required for any of those purposes.

Storage of tools.

(2) A person shall not leave a tool, or any explosive charge made for use in a tool, unattended unless effective precautions are taken to ensure that it will not be removed, handled or used by any person other than a person using or assisting in the use of the tool.

(3) A person shall not load a tool other than at the place at which it is to be used or, except where, by reason of mechanical failure, the tool cannot be unloaded, carry or transport a loaded tool from place to place.

176. (1) Every owner of any explosive charges for a tool shall—

- (a) except where they are stored in bulk storage, cause them to be kept in an approved container or containers provided for that purpose; and
- (b) cause every container in which they are kept, to be, and remain, clearly marked with the words "EXPLOSIVE CHARGES".

Storage of charges.  
Amended by G.G. 3/8/79, p. 2216.

(2) Every person having the custody for the time being of any explosive charges for a tool shall keep them in the approved container or containers provided for that purpose.

(3) A person having the custody of any explosive charges for a tool—

- (a) shall, except when explosive charges are being placed therein or removed therefrom, keep the container or containers locked;
- (b) shall not permit any person, other than a person using or assisting in the use of, a tool, to open any container; or
- (c) shall not use, or permit any other person to use, the container or containers, except for the storage of explosive charges.

## PART X.—USE, STORAGE AND CONVEYANCE OF EXPLOSIVES ON A SITE.

177. (1) In this Part, unless the contrary intention appears—

"commercial vehicle" means a conveyance of any kind used for construction work, but does not include a motor car that is normally used for carrying persons.

Interpretation.

(2) Unless a contrary intention appears, words and expressions in this Part have the same meanings as are assigned to them by the Explosives and Dangerous Goods Act 1961, and Explosives Regulations 1963.

(3) Nothing in these regulations affects any provision of the Explosives and Dangerous Goods Act 1961, and the Explosives Regulations 1963.

178. A person shall not, on a site, use an explosive other than an authorized explosive or a blasting agent.

Only authorized explosives to be used.

179. A person shall not use any explosive on a site unless he holds a shotfirer's permit or uses the explosives under the immediate supervision of a person who holds a shotfirer's permit.

Shotfirer's permit.

180. The main contractor or sub-contractor shall ensure that all explosives on a site—

Storage and conveyance of explosives.

- (a) are stored and kept in a manner that conforms to the Explosives and Dangerous Goods Act 1961 and the Explosives Regulations 1963; and
- (b) are conveyed to or from a magazine and kept on the site in a receptacle that—
  - (i) is lined so as not to have any exposed metal;
  - (ii) has the word "EXPLOSIVES" painted thereon in a conspicuous manner in letters not less than 50 mm in height and of a contrasting colour;
  - (iii) is kept securely locked at all times when not required for use; and
  - (iv) is provided with either handles or a carrying strap to facilitate safe movement.

Carrying of explosives.

181. (1) A person may, on a site, convey a quantity of authorized explosive or blasting agent not exceeding 50 kg in weight if—

- (a) the authorized explosive or blasting agent is conveyed on a commercial vehicle that is in sound mechanical condition;
- (b) the explosive or blasting agent is separated from the driver's seat by a partition; and
- (c) where detonators are carried on the same vehicle—
  - (i) the number of detonators does not exceed 500; and
  - (ii) the detonators are carried in a wooden container placed in the driver's compartment of the vehicle.

(2) A person may, on a site, convey a quantity of authorized explosives or blasting agent not exceeding 250 kg in weight if—

- (a) the authorized explosive or blasting agent is conveyed on a commercial vehicle that is in sound mechanical condition;
- (b) the commercial vehicle carries a fire extinguisher of an approved type and size maintained in proper working order;
- (c) where the quantity of authorized explosive or blasting agent carried exceeds a weight of 50 kg, the commercial vehicle carries notices on both the front and rear bearing the word "EXPLOSIVES" painted in red letters not less than 100 mm high and the notices shall be removed when the vehicle is not carrying explosives; and
- (d) where detonators are carried on the same vehicle—
  - (i) the number of detonators does not exceed 1 000; and
  - (ii) the detonators are carried in a wooden container in the driver's compartment of the vehicle.

(3) A person shall not, on a site, carry or convey or cause or permit to be carried or conveyed on or in a vehicle a quantity of explosives exceeding a weight of 250 kg unless—

- (a) he holds a licence to convey explosives;
- (b) the explosives are carried or conveyed only in the vehicle specified in the licence; and
- (c) the carriage or conveying of the explosives is performed in accordance with the provisions of the Explosives Regulations 1963.

#### PART XI.—COMPRESSED AIR AND DIVING WORK.

Interpretation.

182. In this Part unless the contrary intention appears—

"bail-out system" means a self-contained supply of breathing medium carried by a diver to provide an emergency breathing system in the event of the loss of his primary supply;

"deck decompression chamber" means an approved pressure-resistant structure, including pertinent reinforced openings, penetrations and hatches which experiences high differential pressure and which provides space which is intended for personnel to undergo decompression;

"decompression sickness" means the development during or after diving of any abnormality which is a direct result of a reduction in the tension of inert and other gases dissolved in the body with the production of gas bubbles;

"diver" means a person who is engaged in diving;

"diving" means entering water to carry out work to which the Act applies and being subjected to pressure greater than atmospheric pressure;

"diving sub-contractor" means a person who carries on the business of diving either by himself or by employing others;

"diving supervisor" means a workman who is in charge of diving;

"log book" means a collection of a diver's personal records in the form of Form 7 in the Schedule.

(Form 7.)

Diver to be medically fit.

183. (1) A workman shall not dive unless he is certified by a legally qualified medical practitioner at least once in every twelve months to be physically fit for diving by meeting the requirements set out in Appendix A of the Australian Standard Rules for Underwater Air Breathing Operations CZ 18-1972.



(2) The medical practitioner carrying out the examination in subregulation (1) of this regulation shall record the results of that examination on a form in the form of Form 6. (Form 6.)

(3) A person shall not cause or permit a workman to dive unless that workman has been certified to be medically fit in accordance with this regulation.

184. (1) A person shall not employ any person as a diver unless that person— Qualifications of divers.

- (a) complies with the requirements of regulation 183;
- (b) has had the adequate practical experience to enable him to carry out diving; and
- (c) has a full knowledge and understanding of diving practice and the diving equipment in use by that diver.

(2) For the purposes of paragraph (b) of subregulation (1) of this regulation any or all of the following qualifications or experience may be accepted—

- (a) field experience—
  - (i) written statements from employers;
  - (ii) written statements from diving officers or commanding officers of armed service establishments; or
  - (iii) field operations records or a diver's log book;
- (b) proficiency dives—
  - (i) company field operations records; and
  - (ii) armed service operations records; or
- (c) formal training—
  - (i) armed service qualification certificates;
  - (ii) diving school certificates of completion;
  - (iii) company training programme completion statements.

185. A person shall not employ any person to be a diving supervisor unless that person— Qualifications of diving supervisor.

- (a) complies with the requirements of paragraphs (b) and (c) of subregulation (1) of regulation 184; and
- (b) has a sound knowledge of treatment of decompression sickness; and
- (c) has a sense of responsibility, initiative and ability to cope with emergency situations.

186. A person shall not employ any person to be a diver's attendant unless that person has a working knowledge of— Qualifications of diver's attendant.

- (a) diving work;
- (b) signals used by the diver; and
- (c) the diving plant and equipment in use.

187. (1) The diving sub-contractor or diving supervisor as the case may be is responsible for the control of all diving. Duties at diving.

(2) The diving sub-contractor or diving supervisor—

- (a) shall at all times directly supervise all diving operations that have been assigned to him;
- (b) shall ensure that all persons engaged in the diving operation are qualified to perform their tasks;
- (c) shall ensure that all persons engaged in or concerned with the diving operations under his authority comply with the requirements of these regulations;
- (d) shall allocate the duties of the diver, and the diver who is required to stand by and attendants, and direct them during diving operations;
- (e) shall ensure that the records referred to in these regulations are made and maintained;
- (f) shall ensure that communications with the divers by through-water telephone or life line signal are maintained at all times when the diver is under water; and

- (g) shall ensure that the diving plant and equipment is—
  - (i) of a type suitable for performing that particular operation;
  - (ii) in good working order prior to commencement of the dive; and
  - (iii) properly operated and maintained.

## (3) Every diver shall—

- (a) comply with the regulations in this Part;
- (b) make himself familiar with use of the diving plant and equipment and their limitations and diving procedures; and
- (c) report to the diving supervisor any defect in diving plant and equipment supplied for his use.

(4) A diver's attendant shall give his full attention to attending the diver from the time the diver commences preparation for the dive until the diver is well clear of the water and states that he is fit and well.

(5) A diver's attendant shall not be employed on any task other than attending the diver while the diver is in the water or under pressure.

Limitation on deep or hazardous diving.

188. A person shall not dive or cause or permit a person to dive where—

- (a) the depth of the dive exceeds 25 m; or
- (b) special hazards are known to exist,

unless—

- (c) another diver stands by fully equipped on the surface ready to dive to render assistance to the diver carrying out the work;
- (d) a diving supervisor and a diver's attendant are present; and
- (e) there is available for immediate use by the diver a means of communication in the form of an auditory signalling system.

Limitation on diving.

189. (1) Where no special hazards are known to exist a diver may make a dive of less than 25 m if he is attended by a diver's attendant.

(2) A person shall not carry out diving unless—

- (a) properly maintained plant and equipment that is sufficient and suitable for the operation is provided;
- (b) diving is carried out from a suitable and safe place at which the plant and equipment are properly located and worked;
- (c) suitable access to and egress from the diving is available as near as possible to the location of the diving.

(3) Subject to subregulation (4) of this regulation, the diving sub-contractor shall provide a life line that consists of a cordage rope with a minimum diameter of 8 mm for use between the diver and a diver's attendant but where the diving does not exceed 36 m the diver's breathing medium hose or communication line may be used for this purpose.

(4) Where a self-contained breathing apparatus is used by the divers a "buddy" system of communication may be adopted.

(5) Where diving takes place between the hours of sunset and sunrise the diving sub-contractor shall provide each diver with an electric indicating light that is attached to him.

Forbidden work.

190. Where a diver uses compressed air as a breathing medium he—

- (a) shall not carry out any physical work at a depth greater than 55 m;
- (b) may proceed to a depth of 61 m for twenty minutes or 67 m for fifteen minutes, for observation purposes only; and
- (c) shall not proceed beyond a depth of 67 m.

Purity of breathing medium.

191. (1) The breathing medium for a diver shall conform to the standard for the breathing medium in clause 3.4.2.1 of Australian Standard CZ 18-1972 Rules for Under Water Air Breathing Operation.

(2) Where an air compressor is used to supply the breathing medium, there shall be sufficient auxiliary air provided to ensure that the diver can ascend and complete the required decompression.

(3) The auxiliary air supply prescribed by subregulation (2) of this regulation may be provided through any of the following methods or combinations thereof—

- (a) by use of a sufficiently large low pressure volume reservoir between the compressor and diver;
- (b) by means of a standby air compressor connected, or which, by means of suitable valve arrangements, is capable of being connected, into the air supply system to the diver;
- (c) by means of an emergency supply of compressed air in pressurized cylinders which contain sufficient air to supply the diver during his ascent to the surface, connected, or which by means of suitable valve arrangements is capable of being connected, into the air supply system to the diver; or
- (d) by means of a self-contained "bail out" system.

192. (1) A diving sub-contractor shall ensure that a deck decompression chamber is located near the diving operations so that recompression may commence within—

- (a) twelve hours when a dive of which the depth does not exceed 25 m but requiring recompression is performed; or
- (b) sixty minutes when a dive exceeding 25 m is performed.

(2) The deck decompression chamber referred to in subregulation (1) of this regulation shall be—

- (a) suitable for pressurization to a maximum depth of the dive to be performed but in any event the decompression chamber shall be suitable for pressurization to a depth not less than 50 m; and
- (b) provided with an auxiliary air supply.

(3) A diving sub-contractor shall ensure that the decompression tables in Table B1 in Appendix B of the A.S. CA 18—Rules for Under Water Air Breathing Operations are available on the site.

193. A person shall not dive or be permitted to dive in excess of the times set out below—

- (a) at least twelve hours between dives when diving to a maximum depth of 55 m using air as a breathing medium, unless the dive is of a repetitive type;
- (b) an interval of twenty-four hours following any treatment of minor decompression sickness;
- (c) the interval before recommencing diving following serious cases of decompression sickness shall not be less than that stipulated by a medical practitioner qualified in underwater medicine and a notation to this effect shall be placed in the diver's log book;
- (d) the interval times referred to above shall be measured from the time the diver reaches the surface to the time the diver is to prepare for the next dive; and
- (e) any diver who has taken decompression following a dive to a water depth greater than 25 m shall remain in the vicinity of the decompression chamber and competent operator for a minimum period of one hour following completion of decompression and within one hour's travel time to a workable chamber for four hours following decompression.

194. Underwater air breathing apparatus shall be designed and constructed to conform to the requirements of Australian Standard Z67—1972 "Specification for Underwater Air Breathing Apparatus".

195. A diver shall—

- (a) have a log book for the purpose of recording information of all dives made by him;
- (b) record by log entry the information required in the form of Form 7 relating to each and every dive carried out by him; and
- (c) at all reasonable times, produce his log book for inspection by an inspector.

PART XII.—EXAMINATION FOR CERTIFICATES,  
LICENCES AND PERMITS.

- Interpretation. 196. In this Part unless the contrary intention appears—
- “crane chaser” means a person who slings or directs the movement of loads handled by a crane, where the load while it is being lifted is generally in full view of the crane driver;
- “dogman” means a person who slings or directs the movement of loads handled by a crane, where the load while it is being lifted is not generally in full view of the crane driver;
- “explosive powered tool operator” means a person who is the operator of an explosive powered tool and is the holder of a certificate of competency issued under these regulations;
- “rigger” means a person who is directly responsible for the carrying out of rigging work and is the holder of a certificate of competency issued under these regulations;
- “rigging work” means the use of gear, other than the use of gear for the erection of scaffolding, for the lifting, lowering, moving or positioning of structural steel, plant, or equipment, in connection with the construction, erection, demolition or dismantling of any building or structure or hoisting appliance;
- “scaffolder” means a person who is directly responsible for the erection, alteration or dismantling of scaffolding or gear and is the holder of a certificate of competency issued under these regulations.
- Certificate for Inspector of Construction Safety. 197. (1) Every candidate for the position of Inspector of Construction Safety shall—
- (a) produce satisfactory references from a former employer as to his character and reliability; and
  - (b) satisfy the Chief Inspector that he has been engaged for at least seven years in the building industry.
- (2) Every inspector, prior to permanent appointment, shall pass an examination in terms of subregulation (3) of this regulation, to the satisfaction of the Chief Inspector.
- (3) Every examination for the purposes of this regulation shall be such as demonstrates that the candidate has—
- (a) a sound knowledge of the Act and these regulations;
  - (b) a sound knowledge of the mechanical forces and the stresses which may develop from the use of scaffolding or gear;
  - (c) a thorough working knowledge of all materials comprised by or used in connection with scaffolding gear or mechanical gear;
  - (d) an ability to make a good freehand sketch or working drawing of any kind of scaffolding or gear that may be required; and
  - (e) a sound knowledge of the fundamentals of accident prevention.
- Application for and issue of certificates. 198. (1) Subject to this Part, if the Chief Inspector is satisfied that—
- (a) an applicant possesses the prescribed qualifications, he may issue the certificate of competency applied for by the applicant;
  - (b) a person is no longer competent to act in the employment in respect of which he holds a certificate of competency or that a person has failed to comply either with a condition imposed in the licence held by him or with these regulations, he may suspend or cancel the certificate; and
  - (c) a condition is no longer appropriate to a certificate of competency, he may alter or extend that certificate.
- (2) An application for a certificate of competency under this Part shall be in the form of Form 8.
- (Form 8.)
- (3) If a person satisfies the Chief Inspector that a certificate of competency has been lost or destroyed, he may, on application being made in the form of Form 9, replace the lost certificate.
- (Form 9.)
- (4) The fee for the issue of a certificate of competency or for the replacement of a certificate of competency is \$2.00.

199. If the Chief Inspector is satisfied that a person—
- (a) is not less than 18 years of age;
  - (b) has had not less than six months' experience in approved work; and
  - (c) has passed an examination to demonstrate that he has a sound knowledge of—
    - (i) the precautions and measures to be taken to prevent accidents in connection with the movement of loads by a crane;
    - (ii) the safe and efficient methods of slinging and handling loads;
    - (iii) the safe working loads of and uses of ropes, chains and terminal fittings;
    - (iv) the estimation of the weights of loads composed of different materials;
    - (v) crane signals;
    - (vi) the provisions of these regulations so far as they are relevant to his duties; and
    - (vii) English, so as to enable him to speak the language intelligibly,
- he may issue to that person a certificate of competency as a crane chaser or dogman in the form of Form 10.
- Certificate of competency as crane chaser or dogman.  
(Form 10.)
200. If the Chief Inspector is satisfied that a person—
- (a) is not less than 21 years of age;
  - (b) has had not less than twelve months' experience in rigging work; and
  - (c) has passed an examination to demonstrate that he has a sound knowledge of—
    - (i) the rigging and the safety of rigging involved in the erection, placing in position or dismantling of any building or structure, structural steel, plant, equipment or material (other than scaffolding) that requires the use of gear;
    - (ii) the safe working loads for ropes, chains and slings;
    - (iii) the splicing and knotting of ropes and the making up of slings;
    - (iv) the safe working loads for and the use of gear and equipment;
    - (v) the slinging and lifting of heavy loads;
    - (vi) elementary mathematics;
    - (vii) freehand sketching;
    - (viii) The provisions of these regulations relevant to his duties; and
    - (ix) English, so as to enable him to speak the language intelligibly,
- he may issue to that person a certificate of competency as a rigger in the form of Form 11.
- Certificate of competency as rigger.  
(Form 11.)
201. If the Chief Inspector is satisfied that a person—
- (a) is not less than 18 years of age;
  - (b) has had not less than twelve months' experience in scaffolding work; and
  - (c) has passed an examination to demonstrate that he has a sound knowledge of—
    - (i) the methods used in the construction, dismantling and alteration of scaffolding;
    - (ii) the timbers used in scaffolding, the sizes required, and the possible defects in such timbers;
    - (iii) the gear and component parts used in scaffolding;
    - (iv) elementary mathematics;
    - (v) freehand sketching;
    - (vi) the provisions of these regulations relevant to his duties;
    - (vii) safety precautions and measures relating to the construction, dismantling and alteration of scaffolding; and
    - (viii) English, so as to enable him to speak the language intelligibly,
- he may issue to that person a certificate of competency as a scaffolder in the form of Form 12.
- Certificate of competency as scaffolder.  
(Form 12.)

- Crane chaser or dogman to hold certificate.  
Amended by G.G. 3/8/79, p. 2216.
202. A person acting or employed as a crane chaser or dogman shall hold a certificate of competency as a crane chaser or dogman issued under regulation 199 or as a rigger issued under regulation 200.
- Workman to hold rigging permit.  
Amended by 3/8/79, p. 2216. (Form 13.)
203. (1) A workman shall not assist in rigging works or be required or permitted to assist in rigging work unless he—
- has had at least three months' experience in construction work; and
  - is the holder of a permit in the form of Form 13.
- (2) A person shall not carry out rigging work and a main contractor or sub-contractor shall not cause or permit or suffer a person to carry out rigging work unless that person holds a certificate of competency as a rigger or carries out the rigging work under the immediate supervision of a rigger.
- (3) A rigger shall not supervise or be required or permitted to supervise more than four workmen on a site at any one time.
- Scaffolder to carry out scaffolding.
204. (1) A person shall not erect, alter or dismantle scaffolding or cause or permit a person to erect, alter or dismantle scaffolding, other than scaffolding that does not or is not intended to exceed a height of 6 m, unless a scaffolder who holds a certificate of competency under regulation 201 is present on the site and supervises the erection, alteration or dismantling of the scaffolding.
- (2) A scaffolder shall not supervise or be required or permitted to supervise more than four workmen.
- Explosive powered tool operator.  
(Form 14.)
205. (1) If the Chief Inspector is satisfied that a person—
- is over the age of 18 years;
  - is proficient in the safe use, adjustment, assembly and taking apart of any tool or tools;
  - is not suffering from any defect of colour vision that would render him unfit to use a tool;
  - has a thorough knowledge of Part IX of these regulations; and
  - has a knowledge of English so as to enable him to speak the language intelligibly,
- he may issue to him a certificate of competency in the form of Form 14.
- (2) The Chief Inspector may accept a person as proficient under paragraph (b) of subregulation (1) of this regulation if that person produces to him proof to the satisfaction of the Chief Inspector that he has passed an approved proficiency test.
- Provisional certificates.  
(Form 15.)
206. (1) If the Chief Inspector is satisfied that a person—
- has attained the age of 18 years;
  - has had twelve months' experience in scaffolding work to be specified in the certificate to be issued to him; and
  - is able to demonstrate by examination that he is competent to perform work that is to be performed by the holder of the certificate as endorsed on that certificate,
- he may issue to that person a provisional scaffolder's certificate in the form of Form 15.
- (2) If the Chief Inspector is satisfied that a person—
- has attained the age of 21 years;
  - has had twelve months' experience in rigging work; and
  - is able to demonstrate by examination that he is competent to perform the rigging work that is to be performed by the holder of the certificate as endorsed on that certificate,
- he may issue to that person a provisional rigger's certificate in the form of Form 16.
- (Form 16.)

(3) The Chief Inspector may endorse a provisional certificate issued under subregulation (1) or (2) of this regulation with one or both of the following terms and conditions—

- (a) that the holder of the provisional certificate enrol for and continue studies in an approved course; or
- (b) that the provisional certificate is valid for the period stated in that certificate.

207. Notwithstanding any other regulation in this Part, if the Chief Inspector is satisfied that a person—

- (a) has attained the age of 18 years;
- (b) has had twelve months' experience in one or more of the classes of construction work in this regulation; and
- (c) has a sound knowledge of—
  - (i) the safe working loads of gear;
  - (ii) the safe working of power driven equipment;
  - (iii) the slinging and lifting of loads;
  - (iv) the provisions of these regulations that are relevant to his duties; and
  - (v) English, so as to enable him to speak the language intelligibly,

he may issue to that person a restricted certificate of competency in the form of Form 17 to perform all or any of the following classes of work—

- (d) the erection of boatswains' chairs or fixed light duty suspended stages;
- (e) the erection or dismantling of tower cranes;
- (f) the erection and demolition of tower hoists;
- (g) the installation, alteration or repair of lifts;
- (h) the erection, alteration or dismantling of scaffolding and gear for ship building;
- (i) steeple jacking.

Restricted certificates of competency. Amended by G.G. 5/3/76, p. 691.

(Form 17.)

#### PART XIII.—FORMS.

Forms.

208. (1) A notice of appeal under section 18 of the Act shall be in the form of Form 18.

(Form 18.)

(2) A direction under section 28 of the Act or an order under section 29 of the Act shall be in the form of Form 19.

(Form 19.)

(3) An inspector's report given under subsection (2) of section 33 shall be in the form of Form 20.

(Form 20.)

(4) Notice of accident to be given under subsection (1) of section 35 shall be in the form of Form 21.

(Form 21.)

APPENDIX A 1

NOTE

All dimensions without symbols are in millimetres.  
 Symbol "m" denotes metres.  
 Symbol "φ" denotes diameter.

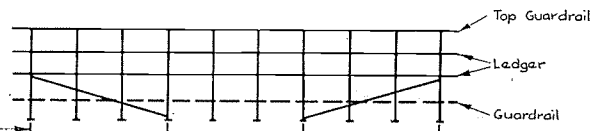
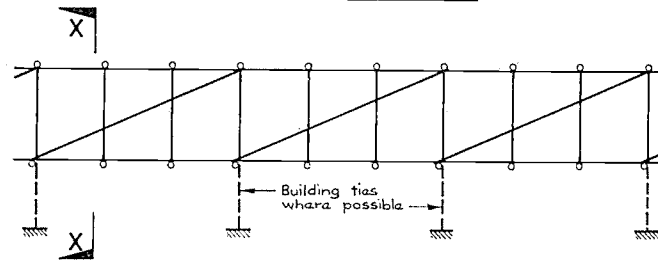
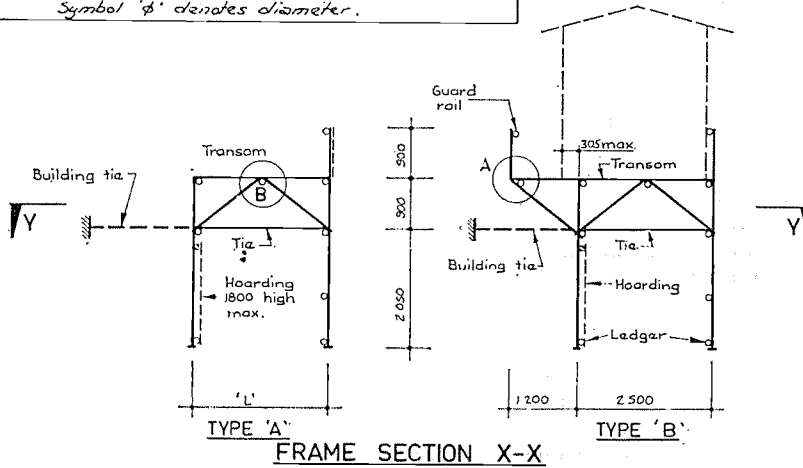

Tube anchor 3 bays apart max & on both standards as alternative to ties

ELEVATION OF COL. BRACING (ONE FACE ONLY)

LOCATIONS		TABLE SHOWING N <sup>o</sup> OF TUBES REQUIRED			
'L'	COMPONENT	SHELTERED FROM WIND		EXPOSED TO WIND	
		100 kg/m <sup>2</sup> LIVE LOAD	360 kg/m <sup>2</sup> LIVE LOAD	100 kg/m <sup>2</sup> LIVE LOAD	360 kg/m <sup>2</sup> LIVE LOAD
1800	STANDARDS	1	1	2	2
	TRANSOMS	1	1	1	1
	LEDGERS & BRACES	1	1	1	1
	TUBE ANCHORS *	460	460	760	760
2500	STANDARDS	1	2	2	2
	TRANSOMS	1	2	1	2
	LEDGERS & BRACES	1	1	1	1
	TUBE ANCHORS *	460	460	610	610
2500 with 1200 overhang	STANDARDS	NOT APPLICABLE	2	NOT APPLICABLE	2
	TRANSOMS		2		2
	LEDGERS & BRACES		1		1
	TUBE ANCHORS *		760		483x4 x 3mtie back

48.3 x4 Scaffolding Tube Gantry

\*USE WHEN GANTRY IS UNSUPPORTED Laterally. SHELTERED AREAS EG. CITY LOCATIONS EXPOSED AREAS EG. SUBURBAN LOCATIONS



APPENDIX A 2

NOTE

All dimensions without symbols are in millimetres.  
 Symbol "m" denotes metres.  
 Symbol "φ" denotes diameter.

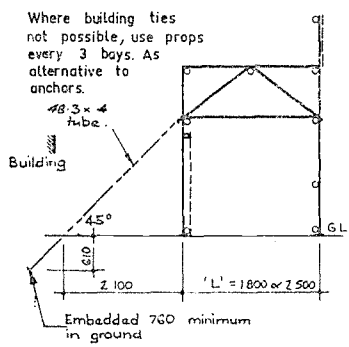

TYPE 'A'

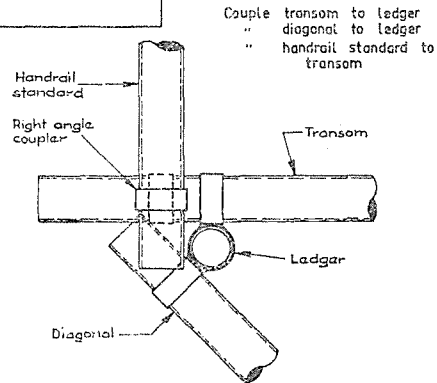

DETAIL A

Couple ledger to transom  
 " inside standard to transom  
 " inside standard to ledger

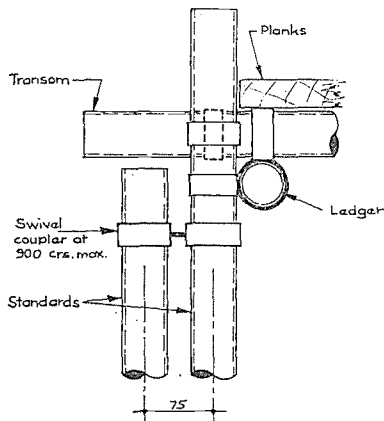

DETAIL OF DOUBLE STANDARD

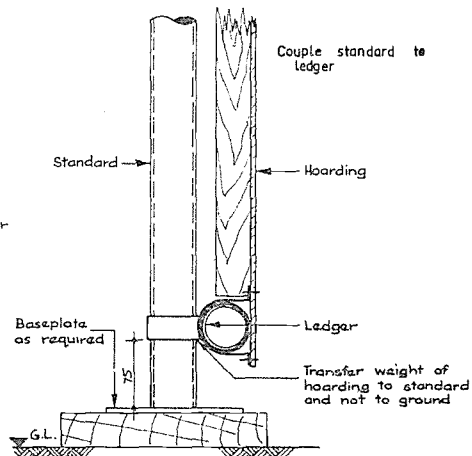

DETAIL OF HOARDING

### APPENDIX A 3

#### NOTES

1. Tube anchors are one per standard, every third frame and are to be to design sketched below.
2. Augered holes for H.D. bolts are to be filled with coarse sand rammed back hard throughout depth. For diagonally propped frame, auger on the rake to suit prop.
3. All tubes shown are 48.3 O.D. x 4
4. Where space restrictions permit use of diagonal props at angles greater than 45°, consult Structures Engineer.
5. All dimensions without symbols are in millimetres.  
Symbol 'm' denotes metres.  
Symbol 'φ' denotes diameter.

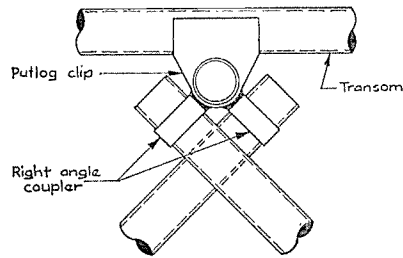

DETAIL B

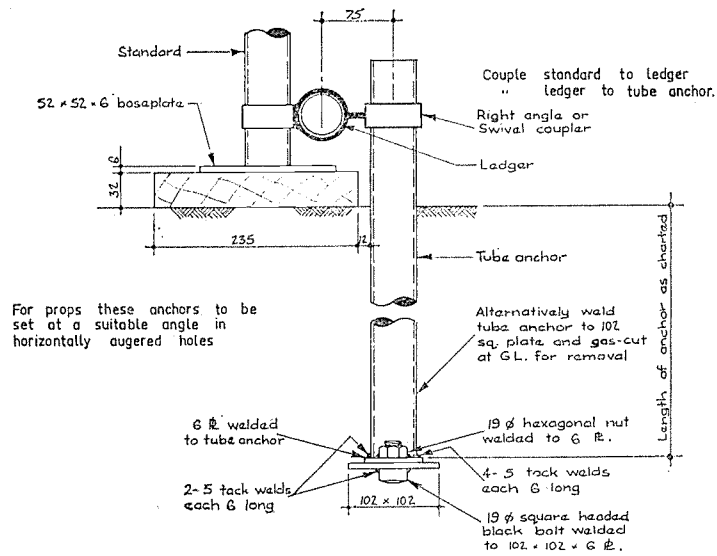

DETAIL OF TUBE ANCHOR

APPENDIX B 1

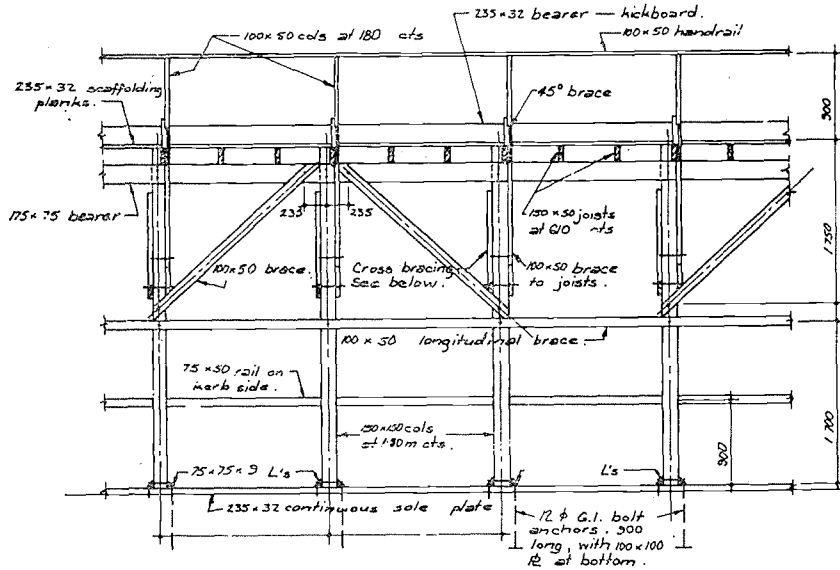

SIDE ELEVATION - VIEW X

All bolts to be 12 φ.

**NOTE**  
 All dimensions without symbols are in millimetres.  
 Symbol 'm' denotes metres. Symbol 'φ' denotes diameter.

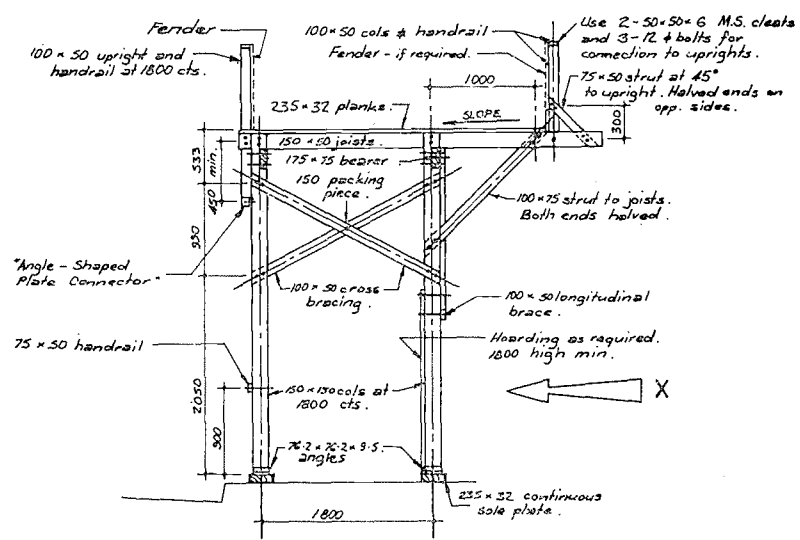

SECTION

FREE-STANDING TIMBER GANTRIES

This gantry drawn for 720 kg/m<sup>2</sup> live load  
 1800x1800 spans with 900 clear width projection.  
 For other loadings, see Table of Component Sizes  
 on Sht.3-4.

**APPENDIX B 2**

*Refer to Sheet 1-4 for definition of measurements.*

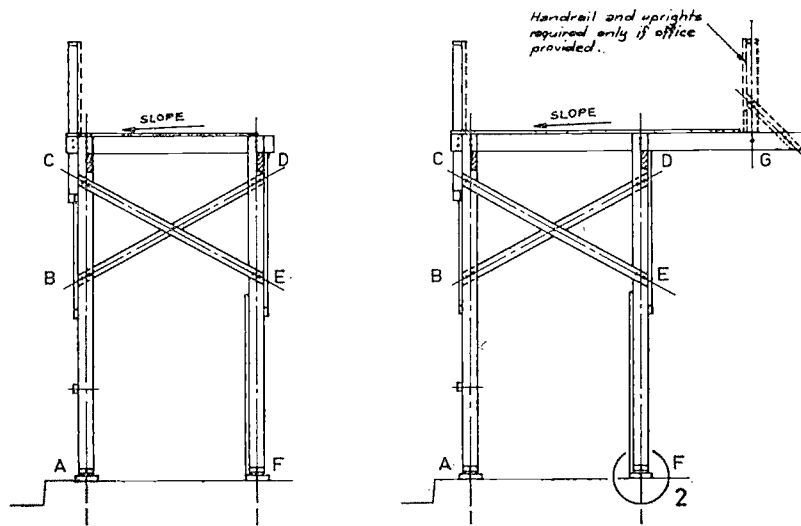

**GANTRY TYPE 'A'**

**GANTRY TYPE 'B'**

*NOTE: See Sheet 1-4 for relative dimensions.  
See Sheet 3-4 for component sizes.*

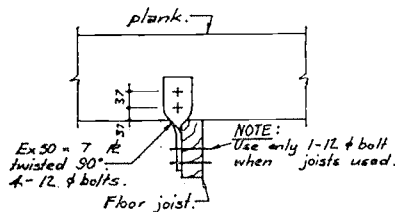

**DETAIL 1**  
*Detail of Bearer 'G' to Floor Joists.*

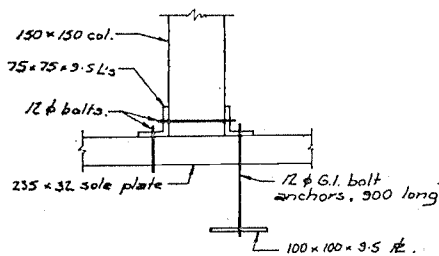

**DETAIL 2**

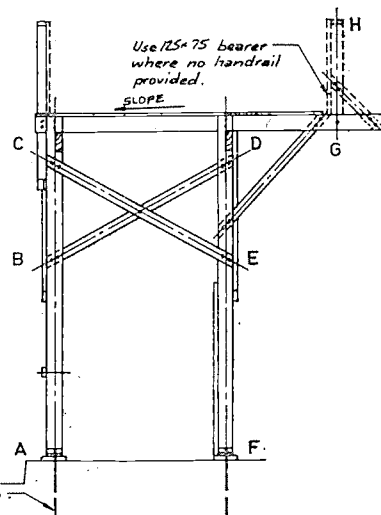

**GANTRY TYPE 'C'**

**FREE-STANDING TIMBER GANTRIES**

TYPE A	TYPE B	TYPE C
No. projection D.G. No strut E.G.	Cantilevered projn. D.G. No strut E.G.	Propped projn. D.G. Use of strut E.G.

NOTE: All dimensions without symbols are in millimetres.

Symbol 'm' denotes metres  
Symbol 'φ' denotes diameter.

FREE-STANDING TIMBER GANTRIES — TABLE OF COMPONENT SIZES

LOADING	720 kg/m <sup>2</sup>						360 kg/m <sup>2</sup>						100 kg/m <sup>2</sup>					
TRANSVERSE SPACING	1800			2400			1800			2400			1800			2400		
GANTRY TYPE	A	B	C	A	B	C	A	B	C	A	B	C	A	B	C	A	B	C
Planks	250 ×38	250 ×38	250 ×38	250 ×38	250 ×38	250 ×38	250 ×38	250 ×38	250 ×38	250 ×38	250 ×38	250 ×38	250 ×38	250 ×38	250 ×38	250 ×38	250 ×38	250 ×38
Columns <u>CA, DF</u>	150 ×150	150 ×150	150 ×150	150 ×150	150 ×150	150 ×150	125 ×125	150 ×150	150 ×150	125 ×125	150 ×150	150 ×150	125 ×125	125 ×125	125 ×125	125 ×125	125 ×125	125 ×125
NOTE: Where gantry has adequate lateral support, reduce dimensions 25 each way and omit bolt anchors																		
Joists <u>CD</u>	150 ×50	—	—	200 ×50	—	—	125 ×38	—	—	150 ×50	—	—	75 ×38	—	—	100 ×38	—	—
Joists <u>CG</u>	—	200 ×50	150 ×50	—	200 ×50	175 ×50	—	200 ×50	125 ×38	—	150 ×50	150 ×50	—	100 ×38	75 ×38	—	100 ×38	100 ×38
Bearer <u>C</u>	175 ×50	175 ×50	175 ×50	200 ×50	200 ×50	200 ×50	125 ×50	125 ×50	125 ×50	150 ×50	150 ×50	150 ×50	75 ×50	75 ×50	75 ×50	100 ×38	100 ×38	100 ×38
Bearer <u>D</u>	175 ×50	250 ×75	175 ×75	200 ×50	250 ×75	200 ×75	125 ×50	200 ×75	175 ×50	150 ×50	175 ×75	150 ×75	75 ×50	100 ×50	100 ×38	100 ×38	125 ×50	100 ×50
Bearer <u>G</u> *	—	—	250 ×38	—	—	250 ×38	—	—	250 ×38	—	—	250 ×38	—	—	250 ×38	—	—	250 ×38
Bracing <u>CE, BD</u>	100 ×50	100 ×50	100 ×50	100 ×75	100 ×75	100 ×75	100 ×50	100 ×50	100 ×50	100 ×75	100 ×75	100 ×75	100 ×50	100 ×50	100 ×50	100 ×75	100 ×75	100 ×75
Strut <u>EG</u>	—	—	100 ×75	—	—	100 ×75	—	—	100 ×50	—	—	100 ×50	—	—	100 ×50	—	—	100 ×50
Upright <u>GH</u>	100 ×50	100 ×50	100 ×50	100 ×50	100 ×50	100 ×50	100 ×50	100 ×50	100 ×50	100 ×50	100 ×50	100 ×50	100 ×50	100 ×50	100 ×50	100 ×50	100 ×50	100 ×50

\* Use 125×75 where no handrail occurs

Refer to Sheet Z-4 for Key to Gantry Types.

Sht 3-4

APPENDIX B 3

APPENDIX B 4

FREE-STANDING TIMBER GANTRIES WITH UNDERPASS

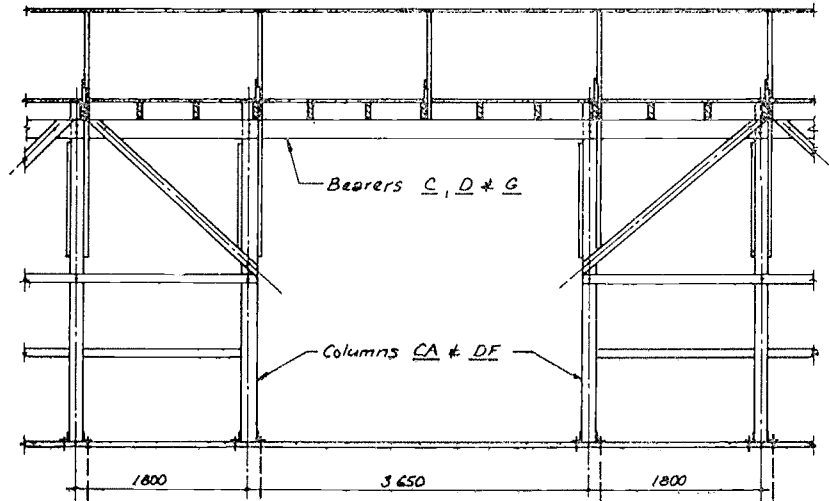

GANTRY WITH 3 650 VEHICLE UNDERPASS

VIEW X

- NOTE :**
1. See Sheet 2-4 for key to gantry types.
  2. See Sheet 1-4 for relative dimensions
  3. See table below for component sizes.
  4. Where gantry has adequate lateral support, reduce column dimensions by 25 each way and omit bolt anchors.

TABLE OF COMPONENT SIZES AT UNDERPASS

LOADING	720 kg/m <sup>2</sup>			360 kg/m <sup>2</sup>			100 kg/m <sup>2</sup>		
	TRVSE SPACING			TRVSE SPACING			TRVSE SPACING		
	1800	2 400	2 400	1 800	2 400	2 400	1 800	2 400	2 400
GANTRY TYPE	A	B	C	A	B	C	A	B	C
Planks	300 x 25	300 x 38	250 x 38	250 x 38	250 x 38	250 x 38	250 x 38	250 x 38	250 x 38
Columns CA, DF	150 x 150	150 x 150	150 x 150	150 x 150	150 x 150	150 x 150	150 x 150	150 x 150	150 x 150
Joists CD	100 x 50	100 x 50	100 x 50	100 x 50	100 x 50	100 x 50	100 x 50	100 x 50	100 x 50
Joists CG	100 x 50	100 x 50	100 x 50	100 x 50	100 x 50	100 x 50	100 x 50	100 x 50	100 x 50
Bearer C	300 x 75	300 x 75	300 x 75	300 x 75	300 x 75	300 x 75	300 x 75	300 x 75	300 x 75
Bearer D	300 x 75	300 x 75	300 x 75	300 x 75	300 x 75	300 x 75	300 x 75	300 x 75	300 x 75
Bearer G	300 x 75	300 x 75	300 x 75	300 x 75	300 x 75	300 x 75	300 x 75	300 x 75	300 x 75
Bracing CE, BD	100 x 50	100 x 50	100 x 50	100 x 50	100 x 50	100 x 50	100 x 50	100 x 50	100 x 50
Strut EG	100 x 50	100 x 50	100 x 50	100 x 50	100 x 50	100 x 50	100 x 50	100 x 50	100 x 50
Upright GH	100 x 50	100 x 50	100 x 50	100 x 50	100 x 50	100 x 50	100 x 50	100 x 50	100 x 50

**NOTE :** All dimensions without symbols are in millimetres  
Symbol 'm' denotes metres. Symbol Ø denotes diameter

SCHEDULE.

Form 1

Reg. 4

Western Australia

CONSTRUCTION SAFETY ACT 1972

Section 9

---

**CERTIFICATE OF APPOINTMENT OF  
AN INSPECTOR OF CONSTRUCTION  
SAFETY**

---

THIS IS TO CERTIFY THAT

Mr. ....  
 has been appointed an Inspector under the Construction Safety Act 1972 and is authorised to exercise the powers of an Inspector assigned to him under that Act and the Regulations in force thereunder.

Signature of Inspector Appointed.....

.....

.....  
*Under Secretary for Labour*

Date.....19.....

CITY }  
TOWN } OF  
SHIRE }

**RETURN OF PROPOSED BUILDING OPERATIONS**

Covering New Buildings, Additions, Alterations, Conversions, Demolitions and Removals, etc.—see instructions on cover

MONTH OF \_\_\_\_\_

1 PERMIT No. OR DATE OF RECEIPT OF NOTICE	2 NAME AND ADDRESS OF OWNER	3 NAME AND ADDRESS OF CONTRACTOR IF "OWNER BUILDER" PLEASE INDICATE	4 SITUATION OF BUILDING STATE LOT OR No., STREET AND TOWN OR SUBURB	5 DESCRIPTION OF BUILDING OR WORK State—1. Type of work (new, additions, renovations, demolitions, etc.). 2. Material of outer walls (brick, concrete, timber framed, asbestos, etc.). 3. Type of building (house, shop, factory, office block, etc.). If multi- storied mark M/S and if house, state if carport or garage attached.	6 FLOOR AREA SQ. FT.	7 ROOF COVERING	8 CGST (LEGISLATING LAW)

72

TO \_\_\_\_\_

I certify that to the best of my knowledge and belief, the particulars given in this return are a true and complete record of proposed building operations known to this Local Authority.

Date .....19..... (Signature).....  
CLERK



**NOTICE OF NOTIFIABLE WORK  
WORK UNDER REG. 16(1)(a).**

Forward to:

Chief Inspector of Construction  
Safety,  
Department of Labour,  
600 Murray Street,  
WEST PERTH, W.A. 6005.  
Tel. 322 0171

Name of Firm giving Notice .....
Address .....

Name of Firm giving Notice Use <b>BLOCK LETTERS</b>  Address  Location of Work Lot or Street No.  Name of Street  Suburb or Town  Type of Work Window Cleaning, Sign Maintenance General Maintenance Ship Building	.....
	.....
	.....
	.....
	.....
	.....
	.....
	.....
	.....
	.....
FEE	\$10.....
Date .....	Signature.....

WESTERN AUSTRALIA  
CONSTRUCTION SAFETY ACT 1972

Section 16

**NOTICE OF NOTIFIABLE WORK  
 WORK UNDER REG. 16(1)(b).**

Contractor's Name .....
Contractor's Address .....

Chief Inspector of Construction  
 Safety,  
 Department of Labour,  
 600 Murray Street,  
 WEST PERTH, W.A. 6005.  
 Tel. 3220171

Job No. or  
 Address of Job  
 (For contractor's reference)

T
Q

Contractor's Name or Trading Name (BLOCK LETTERS)	.....
Contractor's Address	.....
Address of Site	.....
Lot or Street No.	.....
Name of Street	.....
Suburb or Town	.....
State if Construction, Demolition or Excavation Work	.....
Type of Roof Covering	.....
Are Explosives to be used?	.....
Is Diving to be done?	.....
Total Cost of Contract or Estimated Cost of Work:	..... Fee.....
Date .....	Signature .....

WESTERN AUSTRALIA

CONSTRUCTION SAFETY ACT 1972

**CERTIFICATE FOR EXPLOSIVE POWERED TOOL**

It is hereby certified that.....(brand)  
.....(type)  
explosive powered tool Serial No.....which was on.....  
.....declared unsafe for use or submitted for annual overhaul has been repaired and/or\*  
overhauled\* by.....and is free from defects and now cor-  
responds with the approved pattern for a tool of that type.

Signature.....  
(Authorized Person)

Date.....19.....

\*Strike out which is not applicable.

**NOTE:** This Certificate to be completed only by an authorized person. For interpretation of authorized person, see Regulation 152.

WESTERN AUSTRALIA

CONSTRUCTION SAFETY ACT 1972

**MEDICAL CERTIFICATE FOR DIVER**

Certificate of examination of a person as to his medical fitness for employment as a diver.

Name of Diver.....

Address of Diver.....

Date of Examination.....Type.....

Name of Employer.....

Recommendation:      Fit for Diving  
                                 Not Fit for Diving  
                                 (See Remarks)  
                                 Other (Describe)

Remarks.....

.....

.....

.....

.....

Medical examination to be in accordance with the requirements of Appendix A of the Australian Standard Rules for Recommended Practice for Underwater Air Breathing Operations AS CZ18-1972.

.....  
Signature of Examining Physician

Physician's name and address:

.....

.....

.....

.....

Form 7  
(Page 1)

Reg. 195

Form 7  
(Other Pages)

WESTERN AUSTRALIA

Reg. 195

**CONSTRUCTION SAFETY ACT 1972**

WESTERN AUSTRALIA

**RECORDS OF DIVING**

DEPARTMENT OF LABOUR

Date.....

600-608 Murray Street

Water Depth..... Bottom Time.....

West Perth, W.A. 6005

Performed for.....  
(CONTRACTOR)

**CONSTRUCTION SAFETY ACT 1972**

Site Location.....

Time of Day.....

Equipment Used: SSBA SCUBA OTHER

**DIVER'S LOG BOOK**

**WORK DESCRIPTION**

Name.....

Address.....

**REMARKS**

(Include any unusual aspects of dive or  
incidence of decompression sickness)

Signature of Diver.....

Signature of Diving Supervisor.....

77

Form 8

WESTERN AUSTRALIA

Reg. 198 No.....

CONSTRUCTION SAFETY ACT 1972

Issued.....19.....

# APPLICATION FOR A CERTIFICATE OF COMPETENCY

To the Chief Inspector of Construction Safety,  
Department of Labour,  
600 Murray Street,  
WEST PERTH, W.A. 6005

I hereby make application for a Certificate of Competency as a \*.....  
and submit the following particulars.

\* Insert whether Dogman or Crane Chaser, Explosive Powered Tool Operator, Rigger or Scaffolder.

Name of Applicant (Block Letters)	Surname	Other Names	Date of Birth
Address	..... .....		
Length and Nature of Experience	..... .....		
Date .....	.....19.....	Signature of Applicant .....	
Details of any other Certificates held	..... ..... .....		

WESTERN AUSTRALIA

CONSTRUCTION SAFETY ACT 1972

**APPLICATION FOR A REPLACEMENT OF  
A CERTIFICATE OF COMPETENCY OR PERMIT**

Regulation 188

To The Chief Inspector of  
Construction Safety,  
Department of Labour,  
600 Murray Street,  
WEST PERTH. W.A. 6005

I hereby make application for a re-issue of a

- \* Certificate of Competency as a .....
- \* Permit to be Engaged as a Member of a Rigging Gang

The original

- \* Certificate of Competency as a .....
- \* Permit to be Engaged as a Member of a Rigging Gang
  - \* (a) has been lost
  - \* (b) has been destroyed
  - \* (c) whereon the particulars have become illegible and is attached hereto

Surname .....  
(Block Letters)

Other Names .....  
(Block Letters)

Address .....

Date of Birth .....

Name and Address of Present Employer .....

I do solemnly and sincerely declare that I am the person to whom a

- \* Certificate of Competency as a .....
- \* Permit to be Engaged as a Member of a Rigging Gang

was granted and I make this solemn declaration by virtue of Section One Hundred and Six of the Evidence Act, 1906.

Signature .....

Declared before me at ....., this ..... day of ..... 19.....

..... Justice of the Peace.

\* Strike out which is not applicable.

Form 10 No. .... Reg. 199

DEPARTMENT OF LABOUR  
Western Australia  
CONSTRUCTION SAFETY ACT 1972

**CERTIFICATE OF COMPETENCY  
AS A  
CRANE CHASER OR DOGMAN**

THIS IS TO CERTIFY THAT

Signature.....  
is qualified as a Crane Chaser or Dogman under and for the purpose of the abovementioned Act.

.....  
Chief Inspector  
Date.....19.....

Form 11 No. .... Reg. 200

DEPARTMENT OF LABOUR  
Western Australia  
CONSTRUCTION SAFETY ACT 1972

**CERTIFICATE OF COMPETENCY  
AS A  
RIGGER**

THIS IS TO CERTIFY THAT

Signature.....  
is qualified as a Rigger under and for the purpose of the abovementioned Act.

.....  
Chief Inspector  
Date.....19.....

Form 12 No. .... Reg. 201

DEPARTMENT OF LABOUR  
Western Australia  
CONSTRUCTION SAFETY ACT 1972

**CERTIFICATE OF COMPETENCY  
AS A  
SCAFFOLDER**

THIS IS TO CERTIFY THAT

Signature.....  
is qualified as a Scaffolder under and for the purpose of the abovementioned Act.

.....  
Chief Inspector  
Date.....19.....



WESTERN AUSTRALIA

CONSTRUCTION SAFETY ACT 1972

**PERMIT TO BE ENGAGED IN RIGGING WORK**

This is to certify that.....

Signature..... has qualified to  
be engaged in rigging work.

.....  
CHIEF INSPECTOR.

Date.....19.....

NOTE: This is NOT a Certificate of Competency

Form 14

No.....

Reg. 205

Western Australia

CONSTRUCTION SAFETY ACT 1972

---

**CERTIFICATE OF COMPETENCY  
EXPLOSIVE POWERED TOOL  
OPERATOR**

---

THIS IS TO CERTIFY THAT

.....

Signature.....,  
has been licensed as an operator of explosive powered  
tools under and for the purpose of the above Act.

.....

*Chief Inspector*

Date.....19.....

**PROVISIONAL SCAFFOLDER'S CERTIFICATE**

This is to certify that.....

Signature..... has qualified to act as a

Scaffolder.....

Length and nature of experience.....

.....

.....

.....

Conditions of certificate.....

.....

.....

.....

This certificate expires.....19.....

Date.....19.....

\_\_\_\_\_  
CHIEF INSPECTOR

FORM 16

WESTERN AUSTRALIA  
CONSTRUCTION SAFETY ACT 1972

Reg. 206

**PROVISIONAL RIGGER'S CERTIFICATE**

This is to certify that .....

Signature ..... has qualified to act as a  
Rigger.

Length and nature of experience.....

.....  
.....

Conditions of certificate.....

.....  
.....

This certificate expires .....19.....

Date .....19.....

\_\_\_\_\_  
CHIEF INSPECTOR

FORM 17

WESTERN AUSTRALIA  
CONSTRUCTION SAFETY ACT 1972

Reg. 207

**RESTRICTED CERTIFICATE OF COMPETENCY**

This is to certify that .....

Signature ..... has qualified to supervise  
in .....

.....

\* insert where applicable –

- (a) the erection of boatswain chairs, or fixed light duty suspended stages for use by painters,
- (b) the erection or dismantling of tower cranes,
- (c) the erection or dismantling of tower hoists,
- (d) the erection, alteration or dismantling of scaffolding for ship building,
- (e) steeple jacking.

Date .....19.....

\_\_\_\_\_  
CHIEF INSPECTOR

WESTERN AUSTRALIA  
CONSTRUCTION SAFETY ACT 1972  
Section 18

**NOTICE OF APPEAL AGAINST A DECISION OF THE CHIEF INSPECTOR AND/OR A DIRECTION BY AN INSPECTOR**

To The Minister of Labour,  
600 Murray Street,  
WEST PERTH. W.A. 6005

Take notice that.....appeals against  
(Name of Appellant)  
a decision of the Chief Inspector of Construction Safety given on the.....day of  
.....19..... and/or a direction to.....  
(Name of Appellant)  
by.....an Inspector of Construction Safety, on the.....  
day of.....19..... at:.....  
in the State of Western Australia.

I request that this appeal be heard by (a) \*The Board of Reference, (b) \*Appointed Arbitrator.

The grounds of appeal are as follows: .....  
.....  
.....  
.....  
.....

Signature of Appellant ..... Date.....

NOTE: Original appeal to be given  
to the Minister and a copy  
to the Chief Inspector.

\* Strike out whichever inapplicable.

WESTERN AUSTRALIA

CONSTRUCTION SAFETY ACT 1972  
DIRECTIONS TO MAIN CONTRACTOR  
OR SUB CONTRACTOR (Section 28)  
OR ORDER TO PERSON (Section 29)

To .....

DEPARTMENT OF LABOUR,  
Construction Safety Branch,  
600 Murray Street,  
WEST PERTH, W.A. 6005.

Telephone 322 0171

In exercise of the powers vested in me by the Construction Safety Act 1972, and the Regulations thereunder and in order to prevent accidents and to ensure compliance with such Regulations, I hereby require that you carry out the following directions/or orders in connection with

..... AT .....

Date.....19.....(Inspector)

NOTE: Construction Safety Act 1972, Section 31, provides that any person who refuses or fails to comply with any direction given to him by an Inspector, or any order on appeal from him is liable to a penalty not exceeding \$400.



WESTERN AUSTRALIA

CONSTRUCTION SAFETY ACT 1972

Section 35

Chief Inspector of Construction Safety,  
 Department of Labour,  
 600 Murray Street,  
 WEST PERTH, W.A. 6005

Notification of Accident on  
 Construction Work to be  
 completed and sent to the  
 C.I.C.S. forthwith.

Telephone 322 0171

1 Name of Main Contractor or owner		
Postal Address		
2 Address of Construction Site		
Where accident occurred		
3 Name of Injured Person		
Address (Use Block Letters)		
4 Occupation	Date of Accident	Time of Accident
5 (a) Was accident fatal? (b) If not fatal, extent of injuries. (c) Probable time off.		
6 State whether the accident was in connection with a Crane, Hoist, Plant, Scaffolding, Gear, Building Work, Excavation, Compressed Air, E.P.T. or Brittle Roof.		
7 Cause of the accident. State what the injured person was doing at the time.		
8 If no person was injured, state what was being done at the time.		
Signature of Person giving notice.....		Date.....
Business Address.....		

OFFICE USE ONLY

DIRECTIONS

Chief Inspector of Construction Safety

Date



## Construction Safety Regulations.

### INDEX

	Regulation No.	Act Section
<b>A</b>		
Abrasive blasting	106	
Access		
into and across excavations	129 (b)	
in demolition work	138 (i)	
ladders	88 (g)	
to working places	88 (f)	
Accessways	88 (d) (h) (i)	
Accidents		
inquiry		37
investigation		36
notification		35
report form	208	
Air compressed (see Diving)		6
Air-pollution	105, 106, 108	
Appeals		18
appeal form	208	
hearing of		17
Arbitrator		17
Asbestos roofing	144	
<b>B</b>		
Barricades	78, 79	
Birdcage scaffolds	31	
Boards		
Construction Safety Advisory of reference		19, 20 17
Boatswains chairs		
design and inspection	38	
general	36, 37	
interpretation	35	
specifications	39	
Brittle roofs		
asbestos roofs	146	
box gutters	149	
distance between supports	145	
inspection	151	
interpretation	144	
other brittle material	150	
safety mesh	147, 148	
Building or structure		
interpretation		6
<b>C</b>		
Cantilever hoists	58	
Catch platforms	134, 135	
Certificates of competency		27
application for	198	
crane chaser/dogman	199, 202	
interpretation	196	
powered tool operator	205	
provisional certificates	206	
restricted certificates	207	
rigger	200, 203	
rigging permit	203	
scaffolder	201, 204	
Concrete pumping	74, 94 (1) (f)	

## INDEX—continued

	Regulation No.	Act Section
Compressed air work (see Diving)		
interpretation ....		6
Construction work		
interpretation ....		6
Crane chaser/dogman		
certificate of competency ....	199	
interpretation ....	196	
to be employed ....	202	
<b>D</b>		
Debris, removal of ....	140	
Demolition work		
catch platforms ....	134, 135	
chimney stacks ....	143	
general procedures ....	138	
safety precautions ....	133	
scaffolding ....	134, 136, 137	
removal of material ....	140	
unstable structures ....	142	
use of explosives ....	139	
use of appliances ....	141	
Direction to persons		
inspector may give		28, 29
form ....	208	
Diving		
apparatus and equipment ....	194	
breathing medium ....	191	
diving times ....	193	
duties and responsibilities ....	187	
decompression chamber ....	192	
forbidden work ....	190	
interpretation ....	182	
limitations on diving ....	188, 189	
medical certificate ....	183	
log book ....	195	
qualifications ....	184, 185, 186	
Drums ....	75	
Dust		
general ....	105	
in demolition work ....	138 (h)	
<b>E</b>		
Ear protection ....	103	
Excavation work		
hoisting appliances near	128	6
interpretation ....		
near buildings ....	127	
overburden or surcharge	128	
safety conditions ....	129	
shoring of ....	130	
specifications of shoring	132	
trenches ....	131	
Explosive powered tool		
applications for approval	155	
barrel extensions ....	166	
charges ....	157	
forbidden equipment ....	163	
Explosive powered tool		
forbidden use ....	156, 164, 167, 168, 172	
general requirements ....	154	

INDEX—*continued*

	Regulation No.	Act Section
<b>Explosive Powered Tool—<i>continued</i></b>		
inspection	159	
interpretation	152	6
manufacturers instructions	165	
notification of ownership	158	
operators	153, 205	
protective devices	161	
registration	158	
repair of tools	160	
storage of tools	175	
storage of charges	176	
use of tools	169, 170, 171, 172, 173, 174	
warning notice	162	
<b>Explosives on construction work</b>		
conveyance by a vehicle	181	
interpretations	177	
shotfirer....	179	
storage and carrying of explosives	180	
use of explosives	178	
Eye protection	104	
<b>F</b>		
Fees	14, 15	16 (4)
Fender boards	55	
Fire hazards	107, 111 (b)	
First aid requirements	109	
Footwear	100	
<b>Formwork and falsework</b>		
components	124	
design drawings	126	
general erection	125	
interpretation		6
Frame scaffolding	29	
<b>Friction winch</b>		
cantilever hoist....	59 (3)	
interpretation	56	
skip hoist	64 (4)	
<b>G</b>		
<b>Gantries</b>		
design to be approved	81	
fabricated steel	85	
gates or doors	80	
interpretation	78	
loading	82	
main contractor to provide	79	
scaffold tube	84	
specifications	83	
timber	86	
to remain	87	
Gas cylinders	112	
Gases—noxious	108	
<b>Gear</b>		
examination of	6	
interpretation		6
ladders	67	
lifting clamps	71	
mechanical guarding	70	
safety hook	72	
splicing	68	
slings	73	
wire rope	69	



INDEX—*continued*

	Regulation No.	Act Section
<i>Lifts—continued</i>		
false cars	— 122	
guards and screens	119	
lighting and signalling...	117	
permanent car platforms	120	
power supply	115	
use of car platforms	121	
winches	123	
winch driver	123	
work in an occupied building	118	
<i>Lighting</i>		
general	88 (d), 96 (d)	25
in lift shaft	117	
at night	79 (2) (c)	
M		
<i>Main contractor</i>		
duties of		23
interpretation		6
<i>Material</i>		
lifting and lowering	94	
loading area	94 (1) (d)	
not to be dropped	94 (2)	
on footpaths and roadways	94 (1) (e)	
on landings and access ways	88 (i)	
removal of	94 (1) (c)	
Mobile scaffolding	28	
Modular scaffolding	30	
N		
Night lights	79 (2) (c)	
Noise	103	
<i>Notifiable work</i>		
interpretation	12	6, 16
<i>Notification</i>		
by hire firms	8	
by local authorities	7	
by owner or main contractor	16	
by sub-contractor	17	
of unprotected power lines	92	
O		
Offence—general	11	13, 31, 32
<i>Overhead protection</i>		
for winch drivers	64 (2) (d)	
for the public	37, 43, 79, 94 (1) (d)	
in lift shafts	119	
in welding operations	111 (c)	
<i>Owner</i>		
interpretation		6
P		
Platform planks	53	
<i>Platforms</i>		
cantilevered catch	134, 135	
cantilevered hoist	59 (1) (g), (j)	
false car...	122	
in a lift shaft	121	
interpretation		6

INDEX—*continued*

	Regulation No.	Act Section
<i>Platforms—continued</i>		
landing .....	77	
permanent car .....	120	
tower hoist .....	64 (2) (i)	
working .....	52	
<i>Protective equipment</i>		24
ear protection .....	103	
eye protection .....	104	
fire extinguishers .....	017	
footwear .....	100	
general .....	109	
lifebouys .....	101	
respirators .....	105	
safety belts .....	102	
safety helmets .....	99	
welding and cutting .....	114	
<i>Power lines</i> .....	91, 92	
<i>Power driven equipment</i>		6
interpretation .....		
<i>Power tools</i> .....	98	
<i>Public protection</i> .....	79, 89, 94, 106	
<b>R</b>		
<i>Respiratory protective devices</i> .....	105	
<i>Rigger</i>		
certificate of competency .....	200	
interpretation .....	196	
to be employed .....	203	27
<i>Rigging work</i> .....	196	
<i>Roofs—sheathed with brittle material</i> .....	144	
<i>Ropes—steel wire</i> .....	69	
<i>Rubbish and material on footpaths</i> .....	94 (1) (e)	
<b>S</b>		
<i>Safety</i>		
belts .....	102	
for public .....	79, 89, 94, 106	
for workmen .....	88	
helmets .....	99	
storage of materials and gear .....	87 (a)	
<i>Scaffolder</i>		
certificate of competency .....	201	
interpretation .....	196	
to be employed .....	204	27
<i>Scaffolding</i>		
birdcage .....	31	
boatswain chairs .....	35	
examination of .....	6	
frame .....	29	
general arrangement .....	26	
heavy duty suspended .....	47	
interpretations .....	19	6
light duty suspended .....	40	
loading .....	27	
mobile .....	28	
modular .....	30	
not to be altered .....	89	
on steel tanks .....	34	
planks .....	53	
proof of standard .....	25	
sawn timber .....	32, 33	

INDEX—*continued*

	Regulation No.	Act Section
Scaffolding— <i>continued</i>		
specification for		
fittings and couplers ....	23, 24	
tubes ....	20, 21, 22	
working platforms ....	52	
Sheet piling ....	93	
Shoring		
in demolition ....	138 (c)	
in excavations ....	130	
in formwork ....	125	
interpretation ....		6
of buildings ....	142	
of trenches ....	131, 132	
Slings ....	73	
Splicing of wire rope ....	68	
Sub-contractor		
duties of		23
interpretation ....		6
to give notice ....	17	
Suspended scaffolding (heavy duty)		
design and inspection ....	48, 49	
interpretation ....	47	
loading ....	51	
specification ....	50	
Suspended staging (light duty)		
design and inspection ....	41	
general ....	42, 43, 45	
interpretation ....	40	
loading ....	46	
specifications ....	44	
T		
Tests		
application for ....	10	
Trench work—see excavation work	127	6
V		
Vehicles		
for conveying explosives ....	177	
speed on site ....	88 (e)	
W		
Walkways—see access	88	
Water—danger from	101	
Wire rope	69	
splicing of	68	
Welding and cutting		
electric ....	113	
gas cylinders ....	112	
general ....	110 111	
protective equipment ....	114,	
Winch driver		
lift installation	123	
tower and skip hoists	60	
Winches		
friction ....	59 (1) (h), (3)	
pivoted jib arm	66 (d)	
in lift installation	123	
tower or skip hoist	64 (2) (g)	

INDEX—*continued*

	Regulation No.	Act Section
Work		
to which the Act applies .....		15, 16
Working platform—see platforms .....	52	
Workman		
interpretation .....		6