

# Government Gazette

OF

## WESTERN AUSTRALIA

(Published by Authority at 3.30 p.m.)

No. 71]

PERTH: FRIDAY, 4 SEPTEMBER

[1981

### COMMISSION

WESTERN AUSTRALIA, } By His Excellency Rear-Admiral Sir Richard John  
To Wit: } Trowbridge, Knight Commander of the Royal  
RICHARD } Victorian Order, Knight of Grace of the Most  
TROWBRIDGE, } Venerable Order of the Hospital of St. John of  
Governor. } Jerusalem, Governor in and over the State of  
[L.S.] } Western Australia and its Dependencies in the  
Commonwealth of Australia.

TO THE HONOURABLE SIR FRANCIS THEODORE  
PAGE BURT, Knight Commander of the Most  
Distinguished Order of Saint Michael and Saint  
George, Lieutenant Governor of the State of West-  
ern Australia and its Dependencies in the Com-  
monwealth of Australia.

WHEREAS by clause XIV of the Letters Patent passed  
under the Great Seal of the United Kingdom consti-  
tuting the office of Governor of the State of Western  
Australia and its Dependencies, dated 29 October 1900,  
it is provided that in the event of the Governor having  
occasion to be temporarily absent from the seat of  
Government or from the State, he may in every such  
case, by an instrument under the Public Seal of the  
State constitute and appoint the Lieutenant Governor, or  
if there be no such officer, or if such officer be absent  
or unable to act, then any other person, to be his deputy

during such absence, and in that capacity to exercise,  
perform, and execute for and on behalf of the Governor  
during such absence, but not longer, all such powers and  
authorities vested in the Governor by such Letters  
Patent, as shall in and by such instrument be specified;  
and whereas I, the said Governor, propose to absent  
myself temporarily from the seat of Government: Now,  
therefore, I, the said Governor, by virtue and in  
exercise of the powers vested in me as aforesaid, do by  
this instrument under the Public Seal of the State  
constitute and appoint you the said Sir Francis Theodore  
Page Burt as from the date of my departure upon the  
said absence and during such absence to be my deputy,  
and in that capacity to exercise, perform, and execute  
for and on my behalf, as such Governor, all the powers  
and authorities vested in me by the said Letters Patent.

Given under my hand and issued under the Public  
Seal of the said State, at Perth, this 2nd day  
of September, Nineteen hundred and eighty-one.

RICHARD TROWBRIDGE,  
Governor.

GOD SAVE THE QUEEN ! ! !

### Notice to Subscribers

As "Government Gazette" (No. 70) pages 3619 to 3824 contained only the Uniform Building By-laws and as the issue of this is not covered by the Annual Subscription it was not issued to subscribers in the usual manner. Copies may be purchased from—

Parliamentary Papers,  
Government Printer,  
9 Salvado Road, Wembley; or  
Ground Floor, 32 St. George's Terrace, Perth (Superannuation Building).

4 September 1981.

WILLIAM C. BROWN,  
Government Printer.

## Transfer of Land Act 1893.

## PROCLAMATION

WESTERN AUSTRALIA, } By His Excellency Rear-Admiral Sir Richard John  
To Wit: } Trowbridge, Knight Commander of the Royal  
RICHARD } Victorian Order, Knight of Grace of the Most  
TROWBRIDGE, } Venerable Order of the Hospital of St. John of  
Governor. } Jerusalem, Governor in and over the State of  
[L.S.] } Western Australia and its Dependencies in the  
Commonwealth of Australia.

File No. 5735/50, V9.

WHEREAS by the Transfer of Land Act 1893, the Governor is empowered by Proclamation in the *Government Gazette* to revest in Her Majesty as of Her former estate all or any lands, whereof Her Majesty may become the registered proprietor, and whereas Her Majesty is now the registered proprietor of the lands described in the Schedules hereto: Now therefore, I, the Governor with the advice and consent of the Executive Council, do by this my Proclamation revest in Her Majesty, Her Heirs and Successors, the land described in the Schedules hereto as of Her former estate.

Given under my hand and the Public Seal of the said State, at Perth, this 26th day of August, 1981.

By His Excellency's Command,

D. J. WORDSWORTH,  
Minister for Lands.

GOD SAVE THE QUEEN ! ! !

## Schedule.

File No.; Certificate of Title Volume; Folio.

- 279/58—Denmark Lot 69; 1471; 171.  
1771/981—Portion of Murray Location 2 being Lot 20 on Diagram 58678; 1587; 77.  
1599/981—Portion of Swan Location 1370 being Lot 371 on Diagram 49858; 1510; 751.  
3287/72—Karratha Lot 1140; 1450; 131.  
1196/981—Portion of Wellington Location 41 being Lot 44 on Plan 11367; 1420; 185.  
1992/981—Portion of Perth Suburban Lot 257 and being Lot 20 on Plan 350; 1132; 500.  
1992/981—Portion of Perth Suburban Lot 257 and being Lot 21 on Plan 350; 1132; 501.  
1992/981—Portion of Perth Suburban Lot 257 and being Lot 22 on Plan 350; 1132; 502.  
722/77—Portion of Victoria Location 10456; 1571; 897.  
1603/981—Portion of Williams Location 498; 1585; 184.

## Schedule 2.

File No.; Description of Land.

- 2882/79—Portion of Victoria Location 11379 being Lot 143 on Plan 13036 and being part of the land comprised in Certificate of Title Volume 1585 Folio 701.  
1282/980—Portion of Canning Location 31 and being Lot 245 on Diagram 39895 and being part of the land comprised in Certificate of Title Folio 47 Volume 367A and Certificate of Title Volume 283 Folio 159A.  
3998/980—Portion of Canning Location 1 being Lot 276 on Plan 13452 and being part of the land comprised in Certificate of Title Volume 1583 Folio 370.  
2341/79—Portion of Canning Location 17 being Lot 202 on Plan 12942 and being part of the land comprised in Certificate of Title Volume 1568 Folio 91.  
3494/980—Portion of Victoria Location 2520 being Lot 241 on Plan 13406 and being part of the land comprised in Certificate of Title Volume 40 Folio 383A.  
3738/980—Portion of Swan Location 1563 being Lot 96 on Plan 13420 and being part of the land comprised in Certificate of Title Volume 1581 Folio 954.  
3737/980—Portion of Swan Location M1 being Lot 3 on Diagram 60265 and being part of the land comprised in Certificate of Title Volume 1582 Folio 84.  
3256/980—Portion of Cockburn Sound Location 16 being Lot 65 on Plan 13413 and being part of the land comprised in Certificate of Title Volume 1581 Folio 301.  
3490/980—Portion of Forrestdale Lot 387 being Lot 33 on Diagram 60143 and being part of the land comprised in Certificate of Title Volume 1380 Folio 403.  
3835/980—Portion of East Location 21 being Lot 541 on Plan 13433 and being part of the land comprised in Certificate of Title Volume 1584 Folio 307.  
1611/981—Portion of each of York Lots 389, 390 and 391 being Lot 52 on Diagram 55644 and being part of the land comprised in Certificate of Title Volume 1578 Folio 787.  
3118/79—Portion of each of Serpentine Agricultural Area Lots 1 and 2 being Lot 50 on Plan 13067 and being part of the land comprised in Certificate of Title Volume 1592 Folio 660.  
2349/980—Portion of Kalgan Lot 20 being Lot 18 on Diagram 59468 and being part of the land comprised in Certificate of Title Volume 1583 Folio 333.  
1823/981—Portion of Swan Location 1374 being Lot 57 on Plan 13246 and being part of the land comprised in Certificate of Title Volume 1568 Folio 746.  
2536/980—Portion of Victoria Location 708 and being Lot 2 on Plan 13317 and being part of the land comprised in Certificate of Title Volume 1583 Folio 593.  
3930/980—Portion of Murray Location 837 being the land coloured blue and marked Drain Reserve on Plan 13441 and being part of the land comprised in Certificate of Title Volume 1582 Folio 601.  
3003/79—Portion of Sussex Location 256 being Lot 89 on Diagram 58044 and being part of the land comprised in Certificate of Title Volume 1154 Folio 262.  
1252/981—Portion of Cockburn Sound Location 16 being Lot 89 on Plan 9247 and being part of the land comprised in Certificate of Title Volume 213 Folio 189A.  
3049/980—Portion of Kojonup Location 255 being Lot 12 on Plan 13368 and being part of the land comprised in Certificate of Title Volume 1579 Folio 21.  
3445/980—Portion of Forrestdale Lot 399 being Lot 9 on Diagram 60107 and being part of the land comprised in Certificate of Title Volume 1259 Folio 159.  
2945/980—Portion of Wellington Location 281 and being Lot 20 on Plan 13360 and being part of the land comprised in Certificate of Title Volume 535 Folio 89A.  
3997/980—Portion of Plantagenet Location 650 and being the land coloured blue and marked Drain Reserve on Plan 13456 and being part of the land comprised in Certificate of Title Volume 1096 Folio 524.  
1423/981—Portion of Cockburn Sound Location 16 being Lot 2 on Diagram 29060 and being part of the land comprised in Certificate of Title Volume 1274 Folio 990.  
3925/980—Portion of Wagin Lot 741 being Lot 15 on Diagram 60404 and being the balance of the land in Certificate of Title Volume 1585 Folio 226.  
3217/77—Portion of Coondle Estate Lot 69 and being Lot 407 on Plan 13408 and being part of the land comprised in Certificate of Title Volume 1585 Folio 130.  
2852/980—Portion of each of Swan Locations 1489 and 1793 and being Lot 92 on Diagram 59765 and being part of the land comprised in Certificate of Title Volume 1585 Folio 294.

- 1628/981—Portion of Swan Location 16 being Lot 266 on Plan 12105 and being part of the land comprised in Certificate of Title Volume 1483 Folio 201.
- 3495/980—Portion of each of Swan Location 74 and Cockburn Sound Location 356 being Lot 228 on Plan 13401 and being part of the land comprised in Certificate of Title Volume 1581 Folio 221.
- 923/76—Portion of Canning Location 15 being the land bordered blue and marked Drainage Reserve on Diagram 49939 and being the balance of the land comprised in Certificate of Title Volume 1232 Folio 221.
- 3444/980—Portion of Peel Estate Lot 108 being the land coloured blue and marked Drain Reserve on Diagram 60082 and being part of the land comprised in Certificate of Title Volume 1581 Folio 729.
- 2923/980—Portion of Sussex Location 736 being the Lot 15 on Plan 13364 and being part of the land comprised in Certificate of Title Volume 1580 Folio 449.
- 2102/75—Portion of each of Collie Agricultural Lots 28 and 29 being the land coloured blue and marked Drain Reserve on Plan 11308 and being part of the land comprised in Certificate of Title Volume 1585 Folio 692.
- 3582/78—Portion of Canning Location 673 being the land coloured blue and marked Drain Reserve on Plan 12686 and being part of the land comprised in Certificate of Title Volume 1267 Folio 428.
- 3744/980—Portion of each of Swan Locations 1563 and 1623 being Lot 102 on Plan 13417 and being part of the land comprised in Certificate of Title Volume 1581 Folio 931.

## Transfer of Land Act 1893.

## PROCLAMATION

WESTERN AUSTRALIA,} By His Excellency Rear-Admiral Sir Richard John  
To Wit: } Trowbridge, Knight Commander of the Royal  
RICHARD } Victorian Order, Knight of Grace of the Most  
TROWBRIDGE, } Venerable Order of the Hospital of St. John of  
Governor. } Jerusalem, Governor in and over the State of  
[L.S.] } Western Australia and its Dependencies in the  
Commonwealth of Australia.

File No. 5735/50, V8.

WHEREAS by the Transfer of Land Act 1893, the Governor is empowered by Proclamation in the *Government Gazette* to revest in Her Majesty as of Her former estate all or any lands, whereof Her Majesty may become the registered proprietor, and whereas Her Majesty is now the registered proprietor of the land described in the Schedules hereto: Now therefore, I, the Governor with the advice and consent of the Executive Council, do by this my Proclamation revest in Her Majesty, Her Heirs and Successors, the land described in the Schedules hereto as of Her former estates.

Given under my hand the Public Seal of the said State, at Perth, this 26th day of August, 1981.

By His Excellency's Command,  
D. J. WORDSWORTH,  
Minister for Lands.

GOD SAVE THE QUEEN ! ! !

## Schedule 1.

File No.; Certificate of Title Volume; Folio.

- 1696/981—Swan Location 8330; 390; 58A.
- 1046/981—Portion of Cockburn Sound Location 779 and being Lot 302 on Plan 13350; 1574; 771.
- 5132/54—Canning Location 1794; 1510; 425.
- 2887/78—Portion of Boyanup Agricultural Area Lot 302 being Lot 1 on Diagram 60001; 1591; 681.
- 1878/891—Derby Town Lot 257; 1267; 537.

## Schedule 2.

File No; Description of Land.

- 3489/980—Portion of Plantagenet Location 5489 being Lot 9 on Diagram 60157 and being part of the land comprised in Certificate of Title Volume 1222 Folio 11.
- 1664/980—Portion of Victoria Location 9993 being Lot 27 on Diagram 59181 and being part of the land in Certificate of Title Volumes 1202, 1387 Foliors 473 and 478.
- 3739/980—Portion of each of Swan Locations 1563 and 1623 being Lots 97, 98 and 99 on Plan 13419 and being part of the land comprised in Certificate of Title Volume 1581 Folio 970.
- 3247/77—Portion of Canning Location 31 being Lot 43 on Diagram 55255 and being part of the land in Certificate of Title Volume 1291 Folio 813.
- 2996/65—Portion of Canning Location 429 being Lot 76 on Plan 8488 and being part of the land comprised in Certificate of Title Volume 1305 Folio 755.
- 3887/55—Portion of Melville Suburban Lot 11 being Lot 32 on Diagram 60672 and being part of the land comprised in Certificate of Title Volume 1060 Folio 56.
- 1832/981—Portion of Cockburn Sound Location 10 being Lot 127 on Diagram 29907 and being part of the land comprised in Certificate of Title Volume 1288 Folio 605.
- 1318/980—Portion of Mundaring Lot 105 and being Lot 204 on Diagram 58936 and being part of the land comprised in Certificate of Title Volume 1426 Folio 147.
- 492/981—Portion of Leschenault Location 26 and being Lot 5 on Plan 13469 and being part of the land comprised in Certificate of Title Volume 1575 Folio 478.
- 2499/79—Portion of Swan Location 1315 being Lot 568 on Plan 12956 and being part of the land comprised in Certificate of Title Volume 1543 Folio 657.
- 2924/980—Portion of Sussex Location 736 and being Lot 14 on Plan 13364 being part of the land comprised in Certificate of Title Volume 1580 Folio 449.
- 3047/980—Portion of Canning Location 631 being Lot 42 on Plan 13367 and being part of the land comprised in Certificate of Title Volume 1578 Folio 33.
- 3778/67—Portion of Swan Location 1095 being the portion coloured blue and marked Drain Reserve on Diagram 37786 and being the balance of the land comprised in Certificate of Title Volume 1183 Folio 316.
- 3491/980—Portion of Plantagenet Location 510 being Lot 331 on Diagram 60183 and being part of the land comprised in Certificate of Title Volume 1586 Folio 247.
- 2785/78—Portion of Avon Location d being Lot 4 on Plan 12849 and being part of the land comprised in Certificate of Title Volume 44 Folio 171A.
- 1989/980—Portion of Wellington Location 337 being the land coloured blue and marked Drain Reserve on Plan 13497 and being part of the land comprised in Certificate of Title Volume 1587 Folio 138.
- 2908/76—Portion of Canning Location 31 being the land coloured blue and marked Drain Reserve on Plan 13318 and being part of the land comprised in Certificate of Title Volume 1577 Folio 701.

## Public and Bank Holidays Act 1972.

## PROCLAMATION

WESTERN AUSTRALIA, } By His Excellency Rear-Admiral Sir Richard John  
To Wit: } Trowbridge, Knight Commander of the Royal  
RICHARD } Victorian Order, Knight of Grace of the Most  
TROWBRIDGE, } Venerable Order of the Hospital of St. John of  
Governor, } Jerusalem, Governor in and over the State of  
[L.S.] } Western Australia and its Dependencies in the  
Commonwealth of Australia.

PURSUANT to the provisions of paragraph (a) of subsection (1) of section 7 of the Public and Bank Holidays Act 1972, I, the Governor, acting with the advice and consent of the Executive Council, do hereby appoint the day specified in the first column of the schedule below to be a bank holiday within the Townsite shown opposite in the second column.

Given under my hand and the Public Seal of the said State at Perth, this 26th day of August nineteen hundred and eighty-one.

By His Excellency's Command,  
R. J. O'CONNOR,  
Minister for Labour and Industry.

GOD SAVE THE QUEEN ! ! !

Column 1 (Appointed Day)	Schedule.	Column 2 (Townsite)
20 August, 1981.		Kununurra
31 August, 1981		Paraburdoo
2 September, 1981		Goomalling
2 September, 1981		Boulder
2 September, 1981		Kalgoorlie

## Public and Bank Holidays Act 1972.

## PROCLAMATION

WESTERN AUSTRALIA, } By His Excellency Rear-Admiral Sir Richard John  
To Wit: } Trowbridge, Knight Commander of the Royal  
RICHARD } Victorian Order, Knight of Grace of the Most  
TROWBRIDGE, } Venerable Order of the Hospital of St. John of  
Governor, } Jerusalem, Governor in and over the State of  
[L.S.] } Western Australia and its Dependencies in the  
Commonwealth of Australia.

PURSUANT to the provisions of paragraph (a) of subsection (1) of section 7 of the Public and Bank Holidays Act, 1972, I, the Governor, acting with the advice and consent of the Executive Council, do hereby appoint Thursday, August 27, 1981, to be a public and bank holiday within the Townsite of Wyndham.

Given under my hand and the Public Seal of the said State, at Perth, this 26th day of August, nineteen hundred and eighty-one.

By His Excellency's Command,  
R. J. O'CONNOR,  
Minister for Labour and Industry.

GOD SAVE THE QUEEN ! ! !

AT a meeting of the Executive Council held in the Executive Council Chambers, at Perth, this 26th day of August 1981, the following Orders in Council were authorised to be issued:—

## Land Act 1933.

## ORDER IN COUNCIL.

File No. 5500/26.

WHEREAS by section 33 of the Land Act 1933, it is made lawful for the Governor to direct that any Reserve shall vest in and be held by any person or persons to be named in the Order, in trust for any of the purposes set forth in section 29 of the said Act, or for the like or other public purposes to be specified in such Order and with power of leasing; and whereas it is deemed expedient that Reserve No. 32414 should vest in and be held by Raymond Laurence Young M.L.A. Minister of Public Health for the time being and his successors in office in trust for the purpose of "Government Requirements (Mental Health Services)".

Now, therefore, His Excellency the Governor, by and with the advice and consent of the Executive Council, does hereby direct that the beforementioned Reserve shall vest in and be held by Raymond Laurence Young M.L.A. Minister of Public Health for the time being and his successors in office in trust for "Government Requirements (Mental Health Services)" with power to the said Raymond Laurence Young M.L.A. Minister of Public Health for the time being and his successors in office to lease the whole or any portion thereof for any term not exceeding fifty (50) years from the date of the lease, subject nevertheless to the powers reserved to me by section 37 of the said Act.

J. E. A. PRITCHARD,  
Acting Clerk of the Council.

## Land Act 1933.

## ORDER IN COUNCIL.

File No. 1878/981.

WHEREAS by section 33 of the Land Act 1933, it is made lawful for the Governor to direct that any Reserve shall vest in and be held by any person or persons to be named in the Order, in trust for any of the purposes set forth in section 29 of the said Act, or for the like or other public purposes to be specified in such Order and with power of leasing; and whereas it is deemed expedient that Reserve No. 37340 should vest in and be held by Raymond Laurence Young M.L.A. Minister of Public Health for the time being and his successors in Office in trust for the purpose of "Staff Housing (Public Health Department)".

Now, therefore, His Excellency the Governor, by and with the advice and consent of the Executive Council, does hereby direct that the beforementioned Reserve shall vest in and be held by Raymond Laurence Young M.L.A. Minister of Public Health for the time being and his successors in Office in trust for "Staff Housing (Public Health Department)" with power to the said Raymond Laurence Young M.L.A. Minister of Public Health for the time being and his successors in Office to lease the whole or any portion thereof for any term, subject nevertheless to the powers reserved to me by section 37 of the said Act.

J. E. A. PRITCHARD,  
Acting Clerk of the Council.

## Land Act 1933.

## ORDER IN COUNCIL.

File No. 1561/60.

WHEREAS by section 33 of the Land Act 1933, it is made lawful for the Governor to direct that any Reserve shall vest in and be held by any person or persons to be named in the Order, in trust for any of the purposes set forth in section 29 of the said Act, or for the like or other public purposes to be specified in such Order and with power of leasing; and whereas it is deemed expedient that Reserve No. 27391 should vest in and be held by the City of Stirling in trust for the purpose of "Public Golf Course".

Now, therefore, His Excellency the Governor, by and with the advice and consent of the Executive Council, does hereby direct that the beforementioned Reserve shall vest in and be held by the City of Stirling in trust for "Public Golf Course" with power to the said City of Stirling subject to the approval in writing of the Minister for Lands to each and every lease or assignment of lease being first obtained, to lease the whole or any portion thereof for any term not exceeding twenty one (21) years from the date of the lease, subject nevertheless to the powers reserved to me by section 37 of the said Act; provided that no such lease or assignment of lease shall be valid or operative until the approval of the Minister for Lands, or an officer authorised in that behalf by the Minister, has been endorsed on the Lease Instrument, or Deed of Assignment, as the case may be.

(The previous Order in Council dated 16 December 1964 is hereby superseded.)

J. E. A. PRITCHARD,  
Acting Clerk of the Council.

Land Act 1933.

ORDERS IN COUNCIL.

WHEREAS by section 33 of the Land Act 1933, it is made lawful for the Governor to direct that any Reserve shall vest in and be held by any person or persons to be named in the order in trust for the like or other public purposes to be specified in such order: And whereas it is deemed expedient as follows:—

File No. 1607/91, V2.—That Reserve No. 2069 should vest in and be held by the Western Australian Wildlife Authority in trust for the purpose of "Conservation of Flora and Fauna".

File No. 1931/09.—That Reserve No. 12046 should vest in and be held by the National Parks Authority of Western Australia in trust for the purpose of "National Park and Water".

File No. 5788/09.—That Reserve No. 12277 should vest in and be held by the Western Australian Wildlife Authority in trust for the purpose of "Conservation of Flora and Fauna".

File No. 12157/10.—That Reserve No. 13108 should vest in and be held by the Minister for Water Resources in trust for the purpose of "Water".

File No. 6096/51.—That Reserve No. 23366 should vest in and be held by the Western Australian Wildlife Authority in trust for the purpose of "Conservation of Flora and Fauna".

File No. 3193/58.—That Reserve No. 25693 should vest in and be held by the Shire of Bridgetown-Greenbushes in trust for the purpose of "Public Recreation".

File No. 2700/16.—That Reserve No. 26814 should vest in and be held by The State Energy Commission of Western Australia in trust for "State Energy Commission Purposes".

File No. 479/61.—That Reserve No. 28047 should vest in and be held by the Western Australian Wildlife Authority in trust for the purpose of "Conservation of Flora and Fauna".

File No. 218/66.—That Reserve No. 28359 should vest in and be held by the City of Stirling in trust for the purpose of "Public Recreation".

File No. 3578/67.—That Reserve No. 29451 should vest in and be held by the Western Australian Wildlife Authority in trust for the purpose of "Conservation of Flora and Fauna".

File No. 4137/68.—That Reserve No. 30971 should vest in and be held by Shire of Albany in trust for the purpose of "Public Recreation".

File No. 2569/70.—That Reserve No. 31059 should vest in and be held by the Shire of Halls Creek in trust for the purpose of "Cemetery Site".

File No. 1809/71.—That Reserve No. 31060 should vest in and be held by the Shire of Halls Creek in trust for the purpose of "Depot Site".

File No. 558/78.—That Reserve No. 35263 should vest in and be held by the Shire of Mundaring in trust for the purpose of "Public Recreation".

File No. 2976/79.—That Reserve No. 36623 should vest in and be held by the City of Stirling in trust for the purpose of "Public Recreation".

File No. 1282/980.—That Reserve No. 36873 should vest in and be held by the Town of Armadale in trust for the purpose of "Public Recreation".

File No. 820/980.—That Reserve No. 37161 should vest in and be held by the Shire of Mandurah in trust for the purpose of "Public Recreation".

File No. 3373/980.—That Reserve No. 37189 should vest in and be held by The State Energy Commission of Western Australia in trust for the purpose of "Padmount Site".

File No. 722/77.—That Reserve No. 37203 should vest in and be held by the Minister for Western Australian Government Railways in trust for "Railway Purposes".

File No. 2537/980.—That Reserve No. 37209 should vest in and be held by the Town of Northam in trust for the purpose of "Public Recreation".

File No. 3181/980.—That Reserve No. 37210 should vest in and be held by the Shire of Wanneroo in trust for the purpose of "Public Recreation".

File No. 2973/980.—That Reserve No. 37231 should vest in and be held by the Shire of Dardanup in trust for the purpose of "Public Recreation".

File No. 1369/79.—That Reserve No. 37233 should vest in and be held by the Shire of Waroona in trust for the purpose of "Public Recreation".

File No. 3168/78.—That Reserve No. 37237 should vest in and be held by the Shire of Manjimup in trust for the purpose of "Public Recreation".

File No. 2945/980.—That Reserve No. 37253 should vest in and be held by the Shire of Capel in trust for the purpose of "Public Recreation".

File No. 1599/981.—That Reserve No. 37268 should vest in and be held by the Metropolitan Water Supply, Sewerage and Drainage Board in trust for "Sewage Purposes".

File No. 1603/981.—That Reserve No. 37278 should vest in and be held by the Minister for Water Resources in trust for the purpose of "Pumping Station Site".

File No. 1252/981.—That Reserve No. 37279 should vest in and be held by the Shire of Mandurah in trust for the purpose of "Public Recreation".

File No. 1628/981.—That Reserve No. 37319 should vest in and be held by the Shire of Mundaring in trust for the purpose of "Public Recreation".

File No. 1771/981.—That Reserve No. 37321 should vest in and be held by the Minister for Water Resources in trust for the purpose of "Sewage Pumping Station Site".

File No. 1046/981.—That Reserve No. 37328 should vest in and be held by the Minister for Water Resources in trust for the purpose of "Sewage Pumping Station Site".

File No. 1696/981.—That Reserve No. 37330 should vest in and be held by the Minister for Community Welfare in trust for "Community Welfare Purposes".

File No. 2994/980.—That Reserve No. 37334 should vest in and be held by the City of Bunbury in trust for the purpose of "Recreation".

File No. 1776/980.—That Reserve No. 37347 should vest in and be held by the Minister for Water Resources in trust for the purpose of "Sewage Pumping Station".

File No. 1992/981.—That Reserve No. 37351 should vest in and be held by Minister for Community Welfare in trust for the purpose of "Community Welfare Purposes".

File No. 3245/79.—That Reserve No. 37367 should vest in and be held by the Shire of West Kimberley in trust for the purpose of "Vocational and Recreational Centre".

File No. 2887/78.—That Reserve No. 37372 should vest in and be held by the Minister for Water Resources in trust for the purpose of "Drain".

File No. 3127/14.—That Reserve No. 37378 should vest in and be held by The Commonwealth of Australia in trust for the purpose of "Country Automatic Exchange".

File No. 5788/09.—That Reserve No. 37384 should vest in and be held by the Shire of Bruce Rock in trust for the purpose of "Effluent Disposal".

File No. 4328/28.—That Reserve No. 37385 should vest in and be held by the Government Employees Housing Authority in trust for the purpose of "Housing (G.E.H.A.)".

Now, therefore, His Excellency the Governor, by and with the advice and consent of the Executive Council, does hereby direct that the beforementioned Reserves shall vest in and be held by the beforementioned bodies in trust for the purposes aforesaid, subject nevertheless to the powers reserved to him by section 37 of the said Act.

J. E. A. PRITCHARD,  
Acting Clerk of the Council.

## Local Government Act 1960-1981.

## ORDERS IN COUNCIL.

WHEREAS by section 288 of the Local Government Act 1960-1981, it shall be lawful for the Governor, on request by a Council of a Municipal District, by Order published in the *Government Gazette* to declare any lands reserved or acquired for use by the public or used by the public as a street, way, public place, bridge or thoroughfare, under the care, control, and management of the Council, or lands comprised in a private street, constructed and maintained to the satisfaction of the Council, or lands comprised in a private street, of which the public has had uninterrupted use for a period of not less than ten years, as a public street and if the Council thinks fit, that the Governor shall declare the width of carriageway and footpaths of the public Street; and whereas the Councils mentioned in the schedule hereto have requested that certain lands named and described in the said schedule, which have been reserved for streets within the said Councils, be declared public streets: Now therefore, His Excellency the Governor, by and with the advice and consent of the Executive Council, doth hereby declare the said lands to be public streets and such land shall, from the date of this Order, be absolutely dedicated to the public as streets within the meaning of any law now or hereafter in force.

J. E. A. PRITCHARD,  
Acting Clerk of the Council.

## Schedule.

## Shire of Busselton.

L. & S. Corres. 557/981 (R 6404).

Road No. 16639. A strip of land 20.12 metres wide, commencing at the southern side of Road No. 196 (Vasse Road) at the northeastern corner of Lot 1 of Sussex Location 2356 (Land Titles Office Diagram 33817) and extending as shown coloured brown and marked R.O.W. on Land Titles Office Diagram 33817 southward along the eastern boundary of that Lot and the easternmost eastern boundary of Location 2356 to terminate at a line in prolongation northeastward of the southeastern boundary of the said Location.

(Public Plan Busselton—Vasse Regional 5.7 10 000.)

## Shire of Harvey.

L. & S. Corres. 1993/79 (R 6418).

Road No. 16650 (Barnes Avenue). The whole of Lot 90 of Leschenault Location 31 as delineated and shown on Land Titles Office Plan 8709.

(Public Plan 411A/40.)

## Shire of Kalamunda.

L. & S. Corres. 2223/981 (R 6521).

Road No. 16718 (Enid Road). A strip of land varying in width commencing at the western terminus of a surveyed road at the southeastern corner of Lot 81 of Canning Location 475 (Land Titles Office Diagram 45650) and extending as shown coloured brown and marked R.O.W. on Land Titles Office Diagrams 42274 and 45650 westward along the southern boundaries of that lot and Lot 82 to terminate at the southwestern corner of the last mentioned lot.

(Public Plan Perth 2 000 25.21.)

## Shire of Wanneroo.

L. & S. Corres. 990/981.

Road No. 5867 (Wattle Avenue) (Widening of Part). That portion of Swan Location 1221 the subject of Land Titles Office Diagram 60428.

(Public Plan Swan 1:10 000 2.4.)

## Water Supply, Sewerage, and Drainage Act 1912-1950.

## Country Towns Sewerage Act 1948-1978.

## Meckering Sewerage.

## ORDER IN COUNCIL.

P.W.W.S. 168/69.

WHEREAS by section 4 of the Water Supply, Sewerage, and Drainage Act 1912-1950 it is provided, *inter alia*, that all sewerage works constructed by the Government and declared by the Governor to be subject to any of the Acts mentioned in the schedule to that Act shall vest in the Minister for Water Resources unless and until those works are vested in a board; and whereas by section 11 of the Public Works Act 1902-1972 the Governor by Order in Council dated 2 April 1969 and published in the *Government Gazette* of 11 April 1969 authorised the Minister for Works to undertake, construct and provide the public work of Meckering Sewerage and Appurtenances on the land coloured green on Plan P.W.D., W.A. 45189-1-1; now therefore His Excellency the Governor with the advice and consent of the Executive Council, in pursuance of the powers contained in section 4 of the Water Supply, Sewerage, and Drainage Act 1912-1950, hereby declares Meckering Sewerage comprising sewage treatment works, pumping station, pumping main and reticulation sewer system together with subsequent reticulation sewer system extensions to be subject to the Country Towns Sewerage Act 1948-1978.

J. E. A. PRITCHARD,  
Acting Clerk of the Council.

## Metropolitan Water Supply, Sewerage, and Drainage Act 1909-1980.

## Metropolitan Sewerage.

## ORDER IN COUNCIL.

M.W.B. 676216/80.

WHEREAS by the Metropolitan Water Supply, Sewerage, and Drainage Act 1909-1980 it is provided that, subject to the provisions of the Act, the Metropolitan Water Supply, Sewerage and Drainage Board shall, with the approval of the Governor, have power to construct provide and extend Water Works, Sewerage Works and Metropolitan Main Drainage Works; and whereas the preliminary requirements of the said Act have been complied with and the plan in respect of the works hereinafter mentioned has been submitted to and approved by the Governor in Council: Now therefore His Excellency the Governor by and with the advice and consent of the Executive Council, does hereby empower the Metropolitan Water Supply, Sewerage and Drainage Board to undertake the construction of the following works under the said Act, namely:—

## Sewerage Reticulation Area 7A Balcatta.

## City of Stirling.

## The construction of:—

- (a) A brick and concrete pumping station and a reinforced concrete well together with a three hundred millimetre diameter rising main and all other apparatus connected therewith.
- (b) Three hundred and eighty millimetre, three hundred and five millimetre, two hundred and thirty millimetre, one hundred and fifty millimetre and one hundred millimetre diameter reticulation pipe sewers together with manholes and all other apparatus connected therewith, as shown on plan M.W.B. 17545A as amended.

This Order in Council shall take effect from 4 September 1981.

J. E. A. PRITCHARD,  
Acting Clerk of the Executive Council.

Metropolitan Water Supply, Sewerage, and Drainage  
Act 1909-1980.

Metropolitan Water Supply.

ORDER IN COUNCIL.

M.W.B. 812332/81.

WHEREAS by the Metropolitan Water Supply, Sewerage, and Drainage Act 1909-1980 it is provided that, subject to the provisions of the Act, the Metropolitan Water Supply, Sewerage and Drainage Board shall, with the approval of the Governor, have power to construct provide and extend Water Works, Sewerage Works and Metropolitan Main Drainage Works; and whereas the preliminary requirements of the said Act have been complied with and the plan in respect of the works hereinafter mentioned has been submitted to and approved by the Governor in Council: Now therefore His Excellency the Governor by and with the advice and consent of the Executive Council, does hereby empower the Metropolitan Water Supply, Sewerage and Drainage Board to undertake the construction of the following works under the said Act, namely:—

City of Stirling and Shire of Bayswater.

900 mm Water Main—Dianella and Noranda—Bunya Street.

The construction of a nine hundred millimetre diameter steel water main below ground and approximately four hundred and thirty metres in length complete with valve pits and all other necessary apparatus commencing at the junction of Gordon Road West and Bunya Street and thence proceeding in a northerly direction along Bunya Street to Bramwell Road and terminating thereat, as shown on plan M.W.B. 17642.

This Order in Council shall take effect from 4 September 1981.

J. E. A. PRITCHARD,  
Acting Clerk of the Executive Council.

Premier of Western Australia,  
Perth, 31 August 1981.

IT is hereby notified for public information that the Governor has approved of the following temporary allocation of portfolios during the absence from the State of the Hon. D. J. Wordsworth, M.L.C. from Wednesday, 2 September to Sunday, 6 September 1981 (inclusive).

The Hon. Gordon Masters, M.L.C. to be Acting Minister for Lands and Forests.

R. D. DAVIES,  
Under Secretary,  
Premier's Department.

#### AUDIT ACT 1904.

(Section 33.)

The Treasury,  
Perth, 4 September 1981.

IT is hereby published for general information that the following officers have been appointed as authorising officers:—

- R. V. Studman, for the office of the Director General of Transport from 1/7/81.
- P. W. Cunningham, for the Police Department from 6/7/81 to 4/9/81.

IT is hereby published for general information that the following officers have been appointed as Certifying Officers:—

- E. C. Wood, for the Local Government Department from 10/8/81.
  - K. Snowball, for the Police Department from 18/8/81.
  - D. Priddy, for the Legal Aid Commission of W.A. from 30/7/81.
- For the Metropolitan Water Board:—
- B. P. Hutchison, from 24/7/81.
  - R. T. Nelson, from 24/7/81.
  - N. Amey, from 27/7/81.

C. J. Fernandes, for the Public Service Board from 17/8/81.

R. K. Nurse, for the Crown Law Department from 1/8/81 to 31/12/81.

P. M. Calleja, for the Public Works Department from 5/8/81 to 9/10/81.

IT is hereby published for general information that the following appointments as Certifying Officers have been cancelled:—

D. N. Sexton, for the Local Government Department from 10/8/81.

D. C. McAllister, for the Legal Aid Commission of W.A. from 30/7/81.

For the Metropolitan Water Board:—

J. Drake-Brockman, from 24/7/81.

R. Lamborn, from 24/7/81.

T. N. Gray, from 24/7/81.

D. J. Harris, from 24/7/81.

#### INQUIRY AGENTS LICENSING ACT 1954.

Application for Licence in the First Instance.

To the Court of Petty Sessions at Armadale:

I, DAVID ROGER AUSTIN, of 74 Meilee Terrace, Kelmscott, occupation Debt Collection Agent, having attained the age of twenty-one years, hereby apply on my own behalf for a licence under the abovementioned Act. The principal place of business will be at Suite 14, 24 Thorogood Street, Victoria Park.

Dated the 19th day of August, 1981.

DAVID R. AUSTIN,  
Signature of Applicant.

#### Appointment of Hearing.

I hereby appoint the 6th day of October, 1981 at 9.30 o'clock in the forenoon as the time for the hearing of the foregoing application at the Court of Petty Sessions at Armadale.

Dated this 28th day of August, 1981.

M. H. JOHNSON,  
Clerk of Petty Sessions.

Objection to the granting of the application may be served on the applicant and the Clerk of Petty Sessions at any time prior to seven days before the date appointed for the hearing.

Chief Secretary's Department,  
Perth, 25 August 1981.

THE Hon. Chief Secretary has approved the appointment of the following persons as Commissioners for Declarations under the Declarations and Attestations Act 1913-1972.

- Arkosi, John; Queens Park.
- Armstrong, Margaret Anne; Caversham.
- Ballardie, Gerald Frederic; Lesmurdie.
- Fiorentino, Adalgisa Ann; Glendalough.
- Fraser, Ian Ralph, Armadale.
- Harland, Olive Mary; Bremer Bay.
- Holt, Gerald; Geraldton.
- Hurst, Glen Warren; Spearwood.
- Kitis, Basil; Balga.
- Lego, Michael Rhett; Claremont.
- Newton, Robert; Scarborough.
- Norton, Janias Clark McCulloch; West Perth.
- Ogden, Neville John; Carine.
- Rutherford, Rodney James; Bunbury.
- Spouse, Raymond John; Narrogin.
- Storey, Patricia Mary; Gosnells.
- Ford, Lynn Wilfrid; Greenwood.
- Saunders James Lawrence; Duncraig.

K. G. SHIMMON,  
Director.

## HEALTH ACT 1911 (AS AMENDED).

Public Health Department,  
Perth, 28 August 1981.  
P.H.D. 124/80/1; Ex. Co. 2631.

HIS Excellency the Governor in Council has appointed pursuant to section 11 of the Health Act 1911 as amended, Miss C. J. MacDonald as a Public Health Official.

J. C. McNULTY,  
Commissioner of Public Health.

## HEALTH ACT 1911 (AS AMENDED).

Public Health Department,  
Perth, 28 August 1981.  
P.H.D. 1587/57, V2.

THE appointment of Miss Elizabeth Re as Health Surveyor to the Town of Narrogin and the Shires of Narrogin, Cuballing, Pingelly, Williams and Boddington for the period 7 September to 4 December 1981 is approved.

J. C. McNULTY,  
Commissioner of Public Health.

## HEALTH ACT 1911 (AS AMENDED).

Public Health Department,  
Perth, 28 August 1981.  
P.H.D. 682/67.

THE appointment of Mr Kevin Pond as Health Surveyor to the Town of Narrogin and the Shires of Pingelly, Williams, Cuballing, Narrogin and Boddington is approved.

J. C. McNULTY,  
Commissioner of Public Health.

## HEALTH ACT 1911 (AS AMENDED).

Public Health Department,  
Perth, 31 August 1981.  
P.H.D. 268/64.

THE appointment of Mr. Peter Robert Williams as Health Surveyor (Meat) to the Shire of Greenough is approved.

The cancellation of the appointment of M. K. W. Beer as Health Surveyor to the Shire of Greenough is hereby notified.

J. C. McNULTY,  
Commissioner of Public Health.

## HEALTH ACT 1911 (AS AMENDED).

Public Health Department,  
Perth, 28 August 1981.  
P.H.D. 354/80.

THE appointment of Mr. R. Green and Mr. G. George as Health Surveyors to the Shire of Boddington is approved.

J. C. McNULTY,  
Commissioner of Public Health.

## HEALTH ACT 1911 (AS AMENDED).

Public Health Department,  
Perth, 28 August 1981.  
P.H.D. 9/74; Ex. Co. 2633.

HIS Excellency the Governor in Council has approved, pursuant to section 119 of the Health Act 1911 (as amended) of the use by the West Pilbara Shire Council as sites for the disposal of refuse by the sanitary landfill method of:

1. Pannawonica refuse disposal site being that area coloured in red at folio 22 of P.H.D. file 9/74.
2. Paraburdoo refuse disposal site that area of land outlined in red at folio 26 of P.H.D. file 9/74.

J. C. McNULTY,  
Commissioner of Public Health.

## PREVENTION OF CRUELTY TO ANIMALS ACT 1920.

Public Health Department,  
Perth, 28 August 1981.  
P.H.D. 211/76; Ex. Co. 2636.

HIS Excellency the Governor in Council has authorised, pursuant to the Prevention of Cruelty to Animals Act and Control of Vivisection and Experiments Regulations 1959, authority for persons named in the Schedule hereunder to perform vivisection or other experiments on animals for a period of twelve months expiring on the stipulated dates:

J. C. McNULTY,  
Commissioner of Public Health.

## Schedule.

- Mr. C. J. Van Erp, 28 February 1982.  
Prof. D. Gareth-Jones, Dr. R. W. Kirkham, Dr. M. G. McCall, Mr P. B. Scutt, Ms. C. S. James, Mr. W T. Potts, Dr. V. Burke, 30 April 1982.  
Dr. J. Fry, Dr. R. P. Herrman, Mr. A. Drayton, Dr. C Harper, Mr. J. Prendergast, Dr. L. R. Matz, Prof. B. A. Kakulas, Prof. R. Taylor, Dr. E. G. C. Tan, 1 May 1982.  
Mr. P. C. Thomson, 31 May 1982.  
Dr. M. Gracey, 8 June 1982.  
Dr. G. Mayrhofer, 8 June 1982.  
Dr. G. J. Sawyer, 30 June 1982.  
Mr. L. G. Butler, 30 June 1982.

## HEALTH ACT 1911 (AS AMENDED).

Shire of Brookton.

IN accordance with the provisions of section 57 of the Health Act 1911 (as amended) the Shire of Brookton hereby gives notice that application, general plan and description have been forwarded to the Commissioner of Public Health for approval to construct an Extension to the Effluent Disposal Scheme and associated works within portion of the Brookton Townsite.

Copy of the general plan and description is available for inspection during normal office hours, at the Office of the Council, Brookton.

Dated this 18th day of August, 1981.

J. W. HUGHES,  
Shire Clerk.



## ROAD TRAFFIC ACT 1974-1980.

## ROAD TRAFFIC CODE AMENDMENT (No. 3) 1981.

MADE by His Excellency the Governor in Executive Council.

- Citation. 1. These regulations may be cited as the Road Traffic Code Amendment (No. 3) 1981.
- Principal regulations. 2. In these regulations the Road Traffic Code 1975\*, as amended, is referred to as the principal regulations.
- Reg. 103 amended. 3. Regulation 103 (1) of the principal regulations is amended by inserting after the definition of "the Act" the following definition—  
" "tow truck" has the same meaning as is given to that expression in the Tow Truck Regulations 1975; "
- Reg. 1208 amended. 4. Regulation 1208 of the principal regulations is amended—  
(a) by inserting after the regulation designation "1208." the sub-regulation designation "(1)"; and  
(b) by inserting the following subregulation—  
" (2) The driver of a tow truck shall not tow a vehicle unless it is fitted with the equipment referred to in regulation 5 (2) of the Tow Truck Regulations 1975, as amended from time to time, and such equipment is operating correctly in accordance with the Vehicle Standards Regulations 1977, as amended from time to time. "

By His Excellency's Command,  
J. E. A. PRITCHARD,  
Acting Clerk of the Council.

\* Reprinted in the *Government Gazette* on 19 March 1980 at pp. 905-940.

## ROAD TRAFFIC ACT 1974-1980.

## VEHICLE STANDARDS AMENDMENT REGULATIONS (No. 5) 1981.

MADE by His Excellency the Governor in Executive Council.

- Citation. 1. These regulations may be cited as the Vehicle Standards Amendment Regulations (No. 5) 1981.
- Reg. 104 amended. 2. Regulation 104 (1) of the Vehicle Standards Regulations 1977\*, as amended, is amended by inserting, after the definition of "axle", the following definition—  
" "bicycle" means any two-wheeled vehicle, not being a scooter, that is designed to be propelled solely by human power; and includes a three-wheeled vehicle so designed, other than one which is not intended for use on a road; "

By His Excellency's Command,  
J. E. A. PRITCHARD,  
Acting Clerk of the Council.

\* Published in the *Government Gazette* of 10 November 1977 at pp. 4136-4189.

## FISHERIES ACT 1905-1979.

## Notice No. 87A.

F. &amp; W. 396/65.

THE Minister for Fisheries and Wildlife acting under sections 10 and 23A of the Fisheries Act 1905-1979, hereby gives notice as follows—

1. Unless taken by hand, the species of fish known as *Panulirus cygnus* (Western Rock Lobster) shall be taken only by means of a device known as a rock lobster pot that conforms to the provisions of this notice.
2. Every rock lobster pot shall have only one entrance or neck which shall be positioned on the upper surface of the pot, having the mouth or entrance parallel to the base of the pot.
3. Every rock lobster pot other than a batten rock lobster pot shall have inserted therein a device that—
  - (a) creates an escape gap that is as nearly as practicable rectangular in shape and measures not less than 305 millimetres in length and not less than 54 millimetres in width;
  - (b) is constructed of either steel rod having a diameter of not less than 9.5 millimetres, or of steel flat-bar having a width of not less than 19 millimetres and a depth of not less than 4.7 millimetres; and
  - (c) is positioned on a side, other than the base, or on the upper surface of the pot so that the longer sides of the gap that it creates are generally parallel to the base of the pot.
4. Every batten rock lobster pot shall have therein an escape gap that—
  - (a) is as nearly as practicable rectangular in shape and measures not less than 305 millimetres in length and not less than 54 millimetres in width; and
  - (b) is positioned on a side, other than the base, or on the upper surface of the pot so that the longer sides of the gap are generally parallel to the base of the pot.
5. A batten rock lobster pot shall not exceed one metre in length when measured internally and parallel to the side of greatest length, and at the greatest length of that side, on a plane parallel to the base.
6. A rock lobster pot other than a batten rock lobster pot shall not exceed one metre when measured internally along the line of greatest length on a plane parallel to the base.
7. A rock lobster pot shall not have any obstruction positioned in such a way as to restrict the movement of rock lobsters through the escape gap or to reduce the internal measurement of the escape gap. Provided that in the case of a rock lobster pot other than a batten rock lobster one wire only may pass perpendicularly across the escape gap and then only across its narrowest measurement.

G. E. MASTERS,  
Minister for Fisheries and Wildlife.

## FISHERIES ACT 1905-1979.

## Part IIB—Processing Licences.

F. &amp; W. 733/81.

THE Public is hereby notified that I have issued a permit to I. Anicich, 15 Earlston Way Booragoon, to establish a processing establishment to process fish in pursuance of the provisions of section 35C of the Fisheries Act 1905-1979, on board licensed fishing boat "Blue Pacific" registered number LFB F84 subject to the following conditions:—

That the processing establishment:

1. Shall comply with the requirements of the Fisheries Act, 1905-1979 and all Regulations, Orders in Council, and Notices and Ministerial Directions issued thereunder.
2. Shall not be used for the processing of rock lobsters or prawns.
3. Shall comply with the requirements of the Health Act 1911 (as amended).
4. Shall be registered as an export establishment pursuant to the provisions of the Export (Fish) Regulations made under the provisions of the Customs Act 1901 (amended) and the Commercial (Trade Descriptions) Act, 1905 (amended) of the Parliament of the Commonwealth should it be used to process fish for export.
5. Shall not be used for the processing of Marron (*Cherax tenuimanus*) unless a license is held under section 39C of the Fisheries Act 1905.
6. Shall not be used for the processing of fish or crustacea caught by any other vessel.

In accordance with provisions of section 35K, any person aggrieved by this decision may, within fourteen days after publication of this notice, appeal against the decision or order by serving on the Minister for Fisheries and Wildlife, a statement in writing of the grounds of their appeal.

B. K. BOWEN,  
Director of Fisheries.

## LAND ACT 1933-1980.

## Reserves.

Department of Lands and Surveys,  
Perth, 4 September 1981.

HIS Excellency the Governor in Executive Council has been pleased to set apart as Reserves the land described below for the purposes therein set forth.

File No. 2785/78.

AVON.—No. 37366 (Public Recreation), Location No. 28641, formerly portion of Avon Location d being Lot 4 on Plan 12849 (8.480 0 hectares). (Plan Beverley SE 1.25 000 (Kokeby East Road Shire of Beverley).)

File No. 5788/09.

AVON.—No. 37384 (Effluent Disposal), Location No. 28709 (9 384 square metres). (Diagram 84676, Plan Bruce Rock 1 : 50 000 (Bruce Rock Road East).)

File No. 690/981.

BOULDER.—No. 37377 (Use and Requirements of the Government Employees Housing Authority), Lot Nos. 2369 and 2371 (2 024 square metres). (Plan Kalgoorlie-Boulder 30.35 (Holmes Street).)

File No. 2887/78.

BOYANUP AGRICULTURAL AREA.—No. 37372 (Drain), Lot No. 420, formerly portion of Boyanup Agricultural Area Lot 302 being Lot 1 on Diagram 60001 (2.028 8 hectares). (Plan Capel NE 1.25 000 (Gavins Road in the Shire of Capel).)

File No. 1196/981.

BUNBURY.—No. 37251 (Housing (Railways), Lot No. 639, portion of Wellington Location 41 being Lot 44 on Plan 11367 (810 square metres). (Plan Bunbury 2000 01.30 (Parry Street).)

File No. 923/76.

CANNING.—No. 36340 (Drain), Location No. 3150, formerly portion of Canning Location 15 being the land bordered blue and marked "Drainage Reserve" on Diagram 49939 (5 634 square metres). (Plan K49-4 (Station Street).)

File No. 2341/79.

CANNING.—No. 37270 (Public Recreation), Location No. 3267, portion of Canning Location 17 being Lot 202 on Plan 12942 (7.579 6 hectares). (Plan Perth 2 000 20.12 and 20.13 (Burslem Drive Thornlie in the City of Gosnells).)

File No. 3998/980.

CANNING.—No. 37350 (Public Recreation), Location No. 3272 formerly portion of Canning Location 1 being Lot 276 on Plan 13452 (4 056 square metres). (Plan Perth 2000 16.17 (Pelican Place Wilson in the City of Canning).)

File No. 3582/78.

CANNING.—No. 37354 (Drain), Location No. 3271, formerly portion of Canning Location 673 being the land coloured blue and marked "Drain Reserve" on Plan 12686 (4 665 square metres). (Plans Kelmscott NW 1 : 25 000 and Mundaring SW 1 : 25 000 (Loaring Road in the Shire of Kalamunda).)

File No. 3256/980.

COCKBURN SOUND.—No. 37276 (Public Recreation), Location No. 2649, portion of Cockburn Sound Location 16 being Lot 65 on Plan 13413 (4 840 square metres). (Plan Mandurah and Environs 2 000 08.40 (Doongin Street Mandurah).)

File No. 1252/981.

COCKBURN SOUND.—No. 37279 (Public Recreation), Location No. 2648, portion of Cockburn Sound Location 16 being Lot 89 on Plan 9247 (2.815 1 hectares). (Plans Mandurah 20.0 6.03 and 7.03 (Fremantle Road).)

File No. 1046/981.

COCKBURN SOUND.—No. 37328 (Sewage Pumping Station Site), Location No. 2645, formerly portion of Cockburn Sound Location 779 and being Lot 302 on Plan 13350 (90 square metres). (Plan Mandurah 2 000 7.40 (Mississippi Drive in the Shire of Mandurah).)

File No. 1423/981.

COCKBURN SOUND.—No. 37356 (Public Recreation), Location No. 2647 (formerly portion of Cockburn Sound Location 16 being Lot 2 on Diagram 29060 (2.488 8 hectares). (Plan F202-4 (Postans Road Hope Valley in the Town of Kwinana).)

File No. 1832/981.

COCKBURN SOUND.—No. 37361 (Public Recreation), Location No. 2654, formerly portion of Cockburn Sound Location 10 being Lot 127 on Diagram 29907 (698 square metres). (Plan Perth 2 000 9.10 (Ahern Street Hamilton Hill in the City of Cockburn).)

File No. 2102/75.

COLLIE AGRICULTURAL AREA.—No. 37358 (Drain), Lot Nos. 85 and 86, formerly portion of each of Collie Agricultural Area Lots 28 and 29 being the land coloured blue and marked "Drain Reserve" on Plan 11308 (3.086 2 hectares). (Plan Bunbury 10 000 2.7 and Bunbury 2 000 9.32 (near South Western Highway in the Shire of Dardanup).)

File No. 1878/981.

DERBY.—No. 37340 (Staff Housing (Public Health Department)), Lot No. 1209, formerly Derby Town Lot 257 (2 023 square metres). (Plans Derby 1:2 000 Pt. 2.07 and Pt. 2.08 (Loch Street).)

File No. 3245/79.

DERBY.—No. 37367 (Vocational and Recreational Centre), Lot No. 1135 (7 178 square metres). (Diagram 84365, Plan Derby 2 000 03.06 (Baobab Street).)

File No. 4328/28.

DOWERIN.—No. 37385 (Housing (G.E.H.A.)), Lot No. 281 (1 003 square metres). (Diagram 84678, Plan Dowerin Townsite (Memorial Avenue).)

File No. 3835/980.

ESPERANCE.—No. 37273 (Public Recreation), Lot No. 836, portion of East Location 21 being Lot 541 on Plan 13433 (2 106 square metres). (Plan E93-4 (Catherine Street Esperance).)

File No. 3490/980.

FORRESTDALE.—No. 37274 (Public Recreation), Lot No. 453, portion of Forrestdale Lot 387 being Lot 33 on Diagram 6014 (855 square metres). (Plan F159-4 (near Dew Street Forrestdale in the Town of Armadale).)

File No. 3445/980.

FORRESTDALE.—No. 37275 (Public Recreation), Lot No. 452, portion of Forrestdale Lot 399 being Lot 9 on Diagram 60107 (908 square metres). (Plan Perth 2 000 18.03 (near Dew Street Forrestdale in the Town of Armadale).)

File No. 2748/79.

GASCOYNE.—No. 37376 (Government Requirements), Location No. 342 (31.481 7 hectares). (Original Plan 14736, Plans Whitmore 10 000 2.2; 3.2 (in the Shire of Carnarvon).)

File No. 3494/980.

GERALDTON.—No. 37292 (Public Recreation), Lot No. 2837, formerly portion of Victoria Location 2520 being Lot 241 on Plan 13406 (3 657 square metres). (Plan Geraldton 2 000 18.16 (near Tobin Way).)

File No. 2349/980.

KALGAN.—No. 37318 (Public Recreation), Lot No. 42, formerly portion of Kalgan Lot 20 being Lot 18 on Diagram 59468 (1 998 square metres). (Plan Kalgan Townsite (near Hassell Highway in the Shire of Albany).)

File No. 3049/980.

KOJONUP.—No. 37269 (Public Recreation), Location No. 9243, portion of Kojonup Location 255 being Lot 12 on Plan 13368 (6.507 2 hectares). (Plan Carrolup 2 000 33.31 (Creek Street Katanning).)

File No. 1318/980.

MUNDARING.—No. 37362 (Public Recreation), Lot No. 271, formerly portion of Mundaring Lot 105 being Lot 204 on Diagram 58936 (1 126 square metres). (Plan M150.4 (Hartung Street Mundaring).)

File No. 1771/981.

MURRAY.—No. 37321 (Sewage Pumping Station Site), Location No. 1742, formerly portion of Murray Location 2 being Lot 20 on Diagram 58678 (367 square metres). (Plan Mandurah and Environs 2 000 04.40 (McLarty Road Shire of Mandurah).)

File No. 3930/980.

MURRAY.—No. 37331 (Drain), Location No. 1743, formerly portion of Murray Location 837 being the land coloured blue and marked "Drain Reserve" on Plan 13441 (452 square metres). (Plan Mandurah 2 000 40.28 (Westbury Way in the Shire of Mandurah).)

File No. 3127/14.

PANTAPIN.—No. 37378 (Country Automatic Exchange), Lot No. 24 (1 012 square metres). (Plan Pantapin Townsite (Railway Street in the Shire of Quairading).)

File No. 3444/980.

PEEL ESTATE.—No. 37341 (Drain), Lot No. 1339, portion of Peel Estate Lot 108 being the land coloured blue and marked "Drain Reserve" on Diagram 60082 (3 062 square metres). (Plan F237-4 (Newbold Road in the Town of Kwinana).)

File No. 3489/980.

PLANTAGENET.—No. 37325 (Public Recreation), Location No. 7487, formerly portion of Plantagenet Location 5489 being Lot 9 on Diagram 60157 (5.037 8 hectares). (Plan Albany Regional 2.2 (South Coast Highway in the Shire of Albany).)

File No. 3997/980.

PLANTAGENET.—No. 37363 (Drain), Location No. 7489, formerly portion of Plantagenet Location 650 and being the land coloured blue and marked "Drain Reserve" on Plan 13456 (467 square metres). (Plan Denmark 2 000 20.08 (Little River Road Denmark).)

File No. 3491/980.

PLANTAGENET.—No. 37368 (Public Recreation), Location No. 7492, formerly portion of Plantagenet Location 510 being Lot 331 on Diagram 60183 (2.073 2 hectares). (Plan Albany 10 000 3.3 (Warren Road in the Shire of Albany).)

File No. 1776/980.

PORT HEDLAND.—No. 37347 (Sewage Pumping Station), Lot No. 5278 (1 247 square metres). (Diagram 84636, Plan South Hedland 2 000 25.24 (Kennedy Street).)

File No. 3069/79.

PORT HEDLAND.—No. 37373 (S.E.C. Terminal), Lot No. 5275 (10.416 7 hectares). Diagram 84651, Plan Port Hedland Regional 5.5 (Whim Creek Road).)

File No. 3118/79.

SERPENTINE AGRICULTURAL AREA.—No. 37332 (Public Recreation), Lot No. 151, formerly portion of each of Serpentine Agricultural Area Lots 1 and 2 being Lot 50 on Plan 13067 (7.350 0 hectares). (Plan F 224-4 (Larsen and Thomas Roads in the Shire of Serpentine-Jarrahdale).)

File No. 3003/79.

SUSSEX.—No. 37271 (Public Recreation), Location No. 4745, portion of Sussex Location 256 being Lot 89 on Diagram 58044 (1 118 square metres). (Plan Broadwater Suburban Area 2 000 20.35 (Bussell Highway Busselton).)

File No. 2923/980.

SUSSEX.—No. 37326 (Public Recreation), Location No. 4744, formerly portion of Sussex Location 736 being Lot 15 on Plan 13364 (4.402 7 hectares). (Plan 440A/40 (in the Shire of Augusta-Margaret River).)

File No. 2924/980.

SUSSEX.—No. 37327 (Public Recreation), Location No. 4743, formerly portion of Sussex Location 736 being Lot 14 on Plan 13364 (3 329 square metres). (Plan 341A/40 (near Caves in the Shire of Augusta-Margaret River).)

File No. 1599/981.

SWAN.—No. 37268 (Sewage Purposes), Location No. 10201, formerly portion of Swan Location 1370 being Lot 371 on Diagram 49858 (4.279 4 hectares). (Plans Perth 2 000 7.04, 8.03, 8.04 (Warrandyte Drive, Whitfords in the Shire of Wanneroo).)

File No. 3738/980.

SWAN.—No. 37272 (Public Recreation), Location No. 10205, portion of Swan Location 1563 being Lot 96 on Plan 13420 (2 024 square metres). Plans Perth 2 000 21.25; 22.25; 21.24; 22.24 (Stewart Road, High Wycombe in the Shire of Kalamunda).)

File No. 3737/980.

SWAN.—No. 37277 (Public Recreation), Location No. 10203, portion of Swan Location M1 being Lot 3 on Diagram 60265 (2.037 0 hectares). (Plan Perth 2 000 15.33 (Garson Court, Noranda in the Shire of Bayswater).)

File No. 1628/981.

SWAN.—No. 37319 (Public Recreation), Location No. 10202, formerly portion Swan Location 16 being Lot 266 on Plan 12105 (1.791 8 hectares). (Plan Perth 2 000 23.30 (Elder Way Road in the Shire of Mundaring).)

File No. 3744/980.

SWAN.—No. 37320 (Public Recreation), Location No. 10209, formerly portion of each of Swan Locations 1563 and 1623 being Lot 102 on Plan 13417 (1.112 1 hectares). (Plans Perth 2 000 21.24 and 22.24 (Brand and Sultana Roads, High Wycombe in the Shire of Kalamunda).)

File No. 3495/980.

SWAN.—No. 37322 (Public Recreation), Location No. 10207, formerly portion of Swan Location 74 and Cockburn Sound Location 356 being Lot 228 on Plan 13401 (451 square metres). (Plan Perth 2 000 11.14 (Leach Highway, Booragoon in the City of Melville).)

File No. 3739/980.

SWAN.—No. 37323 (Public Recreation), Location No. 10208, formerly portion of Swan Locations 1563 and 1623 being Lots 97, 98 and 99 on Plan 13419 (3 938 square metres). (Plans Perth 2 000 22.24, 22.25 (near Brae Road, High Wycombe in the Shire of Kalamunda).)

File No. 1696/981.

SWAN.—No. 37330 (Community Welfare Purposes), Location No. 10206, formerly Swan Location 8330 (7.592 9 hectares). (Plan Perth 2 000 19.33 (Lord Street, Lockridge in the Shire of Swan).)

File No. 1823/981.

SWAN.—No. 37343 (Public Recreation), Location No. 10213, formerly portion of Swan Location 1374 being Lot 57 on Plan 13246 (20.869 8 hectares). (Plan Moore River NW 1:25 000 (Nicklaus Avenue, Shire of Gingin).)

File No. 1992/981.

SWAN.—No. 37351 (Community Welfare Purposes), Location Nos. 10217, 10218 and 10219, formerly portions of Perth Suburban Lots 257 and being Lots 20, 21 and 22 respectively on Plan 350 (1 616 square metres). (Plan Perth 2 000 11.24 (Hensman Road, Subiaco).)

File No. 2852/980.

SWAN.—No. 37357 (Public Recreation), Location No. 10220, formerly portion of each of Swan Locations 1489 and 1793 and being Lot 92 on Diagram 59765 (1 214 square metres). (Plan Perth 2 000 23.23 (Dampiera Court, Maida Vale in the Shire of Kalamunda).)

File No. 72277.

VICTORIA.—No. 37203 (Railway Purposes), Location No. 11447, formerly portion of Victoria Location 10456 (3.015 0 hectares). (Plan Bookara NE & SE 1:25 000 (near Brand Highway in the Shire of Irwin).)

File No. 2536/980.

VICTORIA.—No. 37342 (Public Recreation), Location 11453, portion of Victoria Location 708 being Lot 2 on Plan 13317 (2 583 square metres). (Plan Geraldton 1-2 000 17.06 (near Greenough River Road).)

File No. 2882/79.

VICTORIA.—No. 37369 (Public Recreation), Location 11460, formerly portion of Victoria Location 11379 being Lot 143 on Plan 13036 (3 068 square metres). (Plan Geraldton 2 000 16.13 (Scott Road in the Shire of Greenough).)

File No. 3925/980.

WAGIN.—No. 37352 (Public Recreation), Lot No. 1827, formerly portion of Wagin Lot 741 being Lot 15 on Diagram 60404 (3 571 square metres). (Plan Wagin 2 000 21.36 (Forrest Street).)

File No. 2994/980.

WELLINGTON.—No. 37334 (Recreation), Location Nos. 5354 and 5355 (2.160 2 hectares). (Original Plan 15092, Plans Bunbury and Environs 1.30; 1.31 (Jarvis Street and Prince Phillip Drive).)

File No. 492/981.

WELLINGTON.—No. 37364 (Public Recreation), Location No. 5361, formerly portion of Leschenault Location 26 being Lot 5 on Plan 13469 (1 308 square metres). (Plan Bunbury 2 000 03.31 (Cantwell Court).)

File No. 1603/981.

WILLIAMS.—No. 37278 (Pumping Station Site), Location No. 15709, portion of Williams Location 498 (141 square metres). (Plan Wagin Regional 1:10 000 (Great Southern Highway in the Shire of Wagin).)

File No. 1611/981.

YORK.—No. 37317 (Public Recreation), Lot No. 592, formerly portion of each of York Lots 389, 390, and 391 being Lot 52 on Diagram 55644 (8 381 square metres). (Plan York 2 000 26.23 (Fraser Street).)

B. L. O'HALLORAN,  
Under Secretary for Lands.

## REVOCATION OF ORDERS IN COUNCIL.

Department of Lands and Surveys,  
Perth, 4 September 1981.

IT is hereby notified for general information that His Excellency the Governor in Executive Council has been pleased to revoke as follows:—

Corres. No. 9519/97.—Portion of the Order in Council dated 13 May 1931 whereby Reserve No. 5571 "Common" was placed under the control and management of the Meekatharra Road Board and to approve of the cancellation of the Board as a Board of Management to control and manage the said reserve accordingly.

File No. 2700/16.—The Order in Council issued under portion of Executive Council Minute No. 798 dated 8 March 1973 whereby Reserve No. 26814 was vested in the Shire of Lake Grace in trust for the purpose of "Power Station Site" and to approve of the cancellation of the relevant Vesting Order accordingly.

B. L. O'HALLORAN,  
Under Secretary for Lands.

## AMENDMENT OF RESERVES.

Department of Lands and Surveys,  
Perth, 4 September 1981.

HIS Excellency the Governor in Executive Council has been pleased to approve, under section 37 of the Land Act 1933 of the amendment of the following Reserves:—

File No. 733/87.—No. 610 (at Carnarvon) "Common" to exclude that portion as comprised in Gascoyne location 342 as surveyed and shown on Original Plan 14736 and of its area being reduced to about 1 316.563 8 hectares, accordingly. (Plans Whitmore 10 000 2.2; 3.2; Carnarvon 10.07 (Boor Street).)

File No. 1607/91, V2.—No. 2069 (Victoria District) "Public Utility" to comprise Victoria Location 11450 as shown on Original Plan 15084 and of its area being increased to 206.127 1 hectares accordingly. (Plan Mungarra NW 1:25 000 (near Eradu Road South in the Shire of Greenough).)

File No. 4019/95.—No. 6596 (at Albany) "Park Lands" to comprise Albany Lot 1346 as shown on Lands and Surveys Diagram 84544 and of its area being increased to 3.061 7 hectares accordingly. (Plan Albany and Environs 11.04 (Brunswick Road).)

File No. 10239/04.—No. 9516 (Greenmount Suburban Lot 248) "Government Requirements" to exclude the area surveyed and shown on Lands and Surveys Diagram 84617 as Greenmount Suburban Lot 555 and of its area being reduced to about 3.126 1 hectares, accordingly. (Plan Perth 2 000 25.31 (Burton Road, Greenmount in the Shire of Mundaring).)

File No. 5788/09.—No. 12277 (Avon District) "Sewerage and Protection of Flora" to exclude the area surveyed and shown on Lands and Surveys Diagram 84676 as Avon Location 28709 and of its area being reduced to 39.530 2 hectares, accordingly. (Plan Bruce Rock 1:50 000 (Bruce Rock Road East).)

File No. 3127/14.—No. 15489 (Pantapin Lots 23 and 24) "Public Buildings" to exclude Pantapin Lot 24 and of its area being reduced to 1 009 square metres, accordingly. Plan: Pantapin Townsite (Railway Street in the Shire of Quairading).)

File No. 4950/25.—No. 19160 (Pemberton Lot 33) "Police" to comprise Pemberton Lot 239 as surveyed and shown on Lands and Surveys Diagram 84537 in lieu of Lot 33 and of its area being reduced to 3 014 square metres, accordingly. Plan Pemberton Townsite (Jamieson Street).)

File No. 4328/28.—No. 22903 (Dowerin Lot 190) "Hostel Purposes" to exclude the area surveyed and shown on Lands and Surveys Diagram 84678 as Dowerin Lot 281 and of its area being reduced to 3 049 square metres, accordingly. (Plan Dowerin Townsite (Memorial Avenue).)

File No. 3887/55.—No. 24457 (Swan Locations 5824, 5825 and 6719) "Public Recreation" to include Swan Location 10216 (formerly portion of Melville Suburban Lot 11 being Lot 32 on Diagram 60672) and of its area being increased to 1 983 square metres accordingly. (Plan Perth 2 000 10.19 (near Jutland Parade, Dalkeith in the City of Nedlands).)

File No. 5132/54.—No. 24458 (Canning Location 1352) "Schoolsite" to include Canning Location 3268 (formerly Canning Location 1794) and of its area being increased to 3.250 4 hectares, accordingly. (Plans: K99-4; K115-4 (Robins Road, Roleystone in the Town of Armadale).)

File No. 3245/79.—No. 24904 (Derby Lot 528) "Community Welfare Purposes" to exclude the area surveyed and shown on Lands and Surveys Diagram 84365 as Derby Lot 1135 and of its area being reduced to 9.362 3 hectares accordingly. (Plan: Derby 2 000 03.06 (Baobab Street).)

File No. 279/58.—No. 24949 (Denmark Lot 70) "School Quarters Site" to include Denmark Lot 997 (formerly Denmark Lot 69) and of its area being increased to 2 011 square metres, accordingly. (Plan: Denmark 2 000 21.11 (Brazier Street).)

File No. 2771/59.—No. 25464 (Victoria Location 10548) "Government Requirements" to comprise Victoria Location 11446 as shown on Lands and Surveys Diagram 84523 and of its area being increased to 1.360 1 hectares, accordingly. (Plan: Bookara NE 1:25 000 (Brand Highway, in the Shire of Irwin).)

File No. 2996/65.—No. 28212 (Canning Location 2022) "Recreation" to include Canning Location 3275 (formerly portion of Canning Location 429 being Lot 76 on Plan 8488) and of its area being increased to 1.173 8 hectares, accordingly. (Plan: Perth 2 000 24.19 (Granby Street, Lesmurdie in the Shire of Kalamunda).)

File No. 3287/72.—No. 32313 (at Karratha) "Site for Church and Presbytery" to comprise Karratha Lot 3815 (portion formerly Karratha Lot 1140) as surveyed and shown on Lands and Surveys Diagram 81867 and of its area being increased to 6 074 square metres, accordingly. (Plan: Karratha 2 000 24.22 (Welcome Road, in the Shire of Roebourne).)

File No. 4191/74.—No. 33666 (Karratha Lots 1480 and 1993) "Drain" to exclude that portion surveyed and shown on Lands and Surveys Diagram 81867 as part of Lot 3815 and of its area being reduced to 3.458 4 hectares, accordingly. (Plan: Karratha 2 000 24.22 (Welcome Road, in the Shire of Roebourne).)

File No. 2889/75.—No. 33978 (Greenmount Suburban Lot 535) "Water Supply" to include Greenmount Suburban Lot 555 and of its area being increased to 8 758 square metres, accordingly. (Plan: Perth 2 000 25.31 (Burton Road, Greenmount in the Shire of Mundaring).)

File No. 500/78.—No. 35181 (Kalbarri Lot 528) "Recreation" to exclude that portion as comprised in Kalbarri Lot 586 as surveyed and shown on Lands and Surveys Diagram 84645 and of its area being reduced to 5 693 square metres, accordingly. (Plan: Kalbarri 2 000 26.12 (Magee Crescent).)

File No. 3247/77.—No. 35233 (Canning Location 3017) "Public Recreation" to include Canning Location 3269 (formerly portion of Canning Location 31 being Lot 43 on Diagram 55255) and of its area being increased to 1.971 0 hectares, accordingly. (Plan: Perth 2 000 22.06 (Third Avenue, Westfield in the Town of Armadale).)

File No. 3217/77.—No. 35406 (Coondle Estate Lots 97 and 98) to include Coondle Estate Lot 100 (formerly portion of Coondle Estate Lot 69 being Lot 407 on Plan 13408) and of its area being increased to 26.194 2 hectares, accordingly. (Plan: Avon 10 000 2.8 (near Coondle Drive in the Shire of Toodyay).)

File No. 1514/79.—No. 36402 (Canning Location 3157) "Public Recreation" to include Canning Locations 3257 and 3184 and of its area being increased to 9 669 square metres accordingly. (Plan: Perth 2 000 21.16 (Hinkler Street, Maddington in the City of Gosnells).)

File No. 2499/79.—No. 36570 (Swan Location 10077) "Public Recreation" to include Swan Location 10187 (formerly portion of Swan Location 1315 being Lot 660 on Plan 13185) and 10212 (formerly portion of Swan Location 1315 being Lot 568 on Plan 12956) and of its area being increased to 2.966 9 hectares, accordingly. (Plans: Perth 2 000 11.36; 11.37 (Inveraray Crescent, Hamersley).)

File No. 1282/980.—No. 36873 (Canning Location 3226) "Public Recreation" to include Canning Location 3270 (formerly portion of Canning Location 31 being Lot 245 on Diagram 39895) and of its area being increased to 1.801 1 hectares, accordingly. (Plans: Perth 2 000 22.02 and 22.01 (Selby Street, in the Town of Armadale).)

File No. 1989/980.—No. 37226 (Wellington Location 5350) "Drain" to include Wellington Location 5360 (formerly portion of Wellington Location 337 being the land coloured blue and marked "Drain Reserve" on Plan 13497) and of its area being increased to 9 250 square metres accordingly. (Plan Wellington 1:10 000 1.6 (near Halifax Road, Bunbury).)

File No. 2419/76, V2.—37260 (Swan Location 9934) "Fire Training School" to agree with recalculation of area and of its area as shown on Original Plan 14746 being reduced to 27.326 3 hectares, accordingly. (Plans 2 000 BG34/21.22, 21.23 (Maida Vale Road, Forrestfield in the Shire of Kalamunda).)

B. L. O'HALLORAN,  
Under Secretary for Lands.

#### CANCELLATION OF RESERVES.

Department of Lands and Surveys,  
Perth, 4 September 1981.

HIS Excellency the Governor in Executive Council has been pleased to approve, under section 37 of the Land Act 1933 of the cancellation of the following Reserves:—

File No. 1786/93.—No. 2794 (Cottesloe Suburban Lot 113) "Church Site (Presbyterian)". (Plan Perth 2 000 07.19 (Pearse Street).)

File No. 10667/06.—No. 10578 (North Fremantle Lot 44) "Water Supply". (Plan Perth 2 000 07.16 (Higham Road, North Fremantle).)

File No. 6470/97.—No. 23490 (Coolgardie Lot 2100) "Railway Purposes". (Plan Coolgardie 9.11 (Taylor Street).)

File No. 1884/75.—No. 34541 (Gascoyne Location 339) "Public Utilities Services". (Plan Carnarvon Regional (North West Coastal Highway).)

File No. 625/79.—No. 36230 (Halls Creek Lots 340 and 366) "Use and Requirements of the Government Employees Housing Authority". (Plans Halls Creek 2 000 32.24 and 32.25 (John Flynn Street).)

File No. 1514/79.—No. 36596 (Canning Locations 3257 and 3184) "Public Recreation". (Plan Perth 2 000 21.16 (Hinkler Street, Maddington in the City of Gosnells).)

B. L. O'HALLORAN,  
Under Secretary for Lands.

#### CHANGE OF PURPOSE OF RESERVES.

Department of Lands and Surveys,  
Perth, 4 September 1981.

HIS Excellency the Governor in Executive Council has been pleased to approve, under section 37 of the Land Act 1933, of the change of purpose of the following Reserves:—

File No. 1193/45.—No. 840 (Avon District) being changed from "Water" to "Parkland". (Plan Youraling 40 sheet 2 (York-Williams Road in the Shire of Brookton).)

File No. 1607/91, V.2.—No. 2069 (Victoria Location 11450) being changed from "Public Utility" to "Conservation of Flora and Fauna". (Plan Mungarra NW 1:25 000 (Near Eradu Road South).)

File No. 1931/09.—No. 12046 (Plantagenet District) being changed from "Water" to "National Park and Water". (Plans Owingup SE 1:25 000; Parry Inlet 1:25 000 (William Bay Road).)

File No. 5788/09.—No. 12277 (Avon District) being changed from "Sewerage and Protection of Flora" to "Conservation of Flora and Fauna". (Plan Bruce Rock 1:50 000 (Bruce Rock Road East).)

File No. 6096/51.—No. 23366 (Avon locations 25732, 27169 and 28600) being changed from "Flora and Fauna" to "Conservation of Flora and Fauna". (Plans Jilakin and Pederah 1:50 000 (Reservoir Road East in the Shire of Kondinin).)

File No. 3193/58.—No. 25693 (Bridgetown Lot 853) being changed from "Recreation" to "Public Recreation". (Plan Bridgetown 2 000 30.01 (Hampton Street).)

File No. 2700/16.—No. 26814 (Lake Grace Lots 115 and 159) being changed from "Power Station Site" to "State Energy Commission Purposes". (Plan Lake Grace 2 000 6.17 (Lawson Street).)

File No. 479/61.—No. 28047 (Roe Location 1401) being changed from "Conservation of Flora" to "Conservation of Flora and Fauna". (Plan 375/80 (Holland Track Road in the Shire of Kondinin).)

File No. 2996/65.—No. 28212 (Canning Locations 2022 and 3275) being changed from "Recreation to "Public Recreation". (Plan Perth 2 000 24.19 (Granby Street, Lesmurdie in the Shire of Kalamunda).)

File No. 218/66.—No. 28359 (Swan Location 8057) being changed from "Recreation" to "Public Recreation". (Plan Perth 2 000 14.31 (Chester Avenue, Dianella).)

File No. 5500/26.—No. 32414 (Swan Location 8792) being changed from "Mental Hospital Site" to "Government Requirements (Mental Health Services)". (Plan Perth 2 000 12.19 Duncraig Road, Applecross in the City of Melville).)

B. L. O'HALLORAN,  
Under Secretary for Lands.

#### NAMING OF WILLIAM BAY NATIONAL PARK.

Department of Lands and Surveys,  
Perth, 4 September 1981.

File No. 1931/09.

IT is hereby notified for general information that the name of "William Bay National Park" has been applied to the land contained in Reserve No. 12046.

(Public Plans Owingup SE 1:25 000 and Parry Inlet 1:25 000.)

B. L. O'HALLORAN,  
Under Secretary for Lands.

#### HOUSING ACT 1980.

Cancellation of Dedication.

Department of Lands and Surveys,  
Perth, 4 September 1981.

Corres. 847/44, V4.

IT is hereby notified that His Excellency the Governor in Executive Council has been pleased to cancel under the provisions of the Housing Act 1980, the dedication of the lands described in the following Schedule:—

##### Schedule.

Lot or Location No.; Corres. No.

Cockburn Sound, Location 1813; 1563/56.

Swan, Location 5628; 3931/54.

Swan, Location 5772; 4598/55.

Swan, Location 7112; 2506/58.

Collie, Lot 819; 2682/53.

Corrigin, Lot 212; 6206/48.

B. L. O'HALLORAN,  
Under Secretary for Lands.

#### SUBURBAN LAND.

Department of Lands and Surveys,  
Perth, 4 September 1981.

File No. 2809/76.

HIS Excellency the Governor in Executive Council has been pleased to approve under section 10 of the Land Act 1933 of Avon Locations 28718 to 28728 inclusive being set apart as Suburban Land.

(Plan Northam 40 Sheet 3 (Muluckine Road).)

B. L. O'HALLORAN,  
Under Secretary for Lands.

#### CANCELLATION OF DEDICATION.

Department of Lands and Surveys,  
Perth, 4 September 1981.

Corres. 1200/38.

HIS Excellency the Governor in Executive Council has been pleased to cancel, under the provisions of the Housing Act 1980 the dedication of Boulder Lots 2369 and 2371 to the purpose of the said Act.

(Plan Kalgoorlie Environs 2 000 30.35 (Holmes Street).)

B. L. O'HALLORAN,  
Under Secretary for Lands.

#### CHANGE OF NAME OF STREETS.

City of Gosnells.

Department of Lands and Surveys,  
Perth, 4 September 1981.

File No. 2109/54, V.6.

IT is hereby notified for general information that His Excellency the Governor in Executive Council has been pleased to approve under section 10 of the Land Act 1933, of the change of name of Streets in the City of Gosnells as set out in the Schedule hereunder.

B. L. O'HALLORAN,  
Under Secretary for Lands.

##### Schedule.

(a) Isdell Street to Young Street; being that portion of surveyed road commencing at the northeastern side of Greenough Way and extending northeastward along the northwestern boundary of Lots 440-446 inclusive of Canning Location 16 (Land Titles Office Plan 13071) to terminate at the northern corner of the last mentioned lot.

(b) Part of Station Street to Hayward Road; being that portion of Road No. 4494 commencing at a line joining the northeastern corner of Lot 29 Canning Location 15 (Land Titles Office Diagram 49934) and the southeastern corner of Lot 60 of Location 15 (Diagram 49784) and extending northeastward along the northwestern boundary of Lot 28 (Diagram 48800) and Lot 7 of Location 15 (Diagram 3926) and onward to and along the northwestern boundary of Lots 8, 9 and 10 (Diagram 3926), 3 and 4 (Diagram 52772), 5 and 6 (Diagram 57958), 31 and 30 (Diagram 60431), 2 and 1 (Diagram 49777) and 75 and 76 (Plan 2754) all the said Location 15 to terminate at the northeastern corner of the last mentioned lot.

(c) Part of Astley Street to Lockhart Place; being the whole of Road No. 10485 and that portion of Road No. 3136 commencing at the northeastern side of Albany Highway (Road No. 122) and extending northeastward along the southeastern boundary of Lot 1044 of Canning Location 16 (Land Titles Office Plan 2568) thence northwestward along the northeastern boundary of the said lot and Lots 1043, 1042, 1041 and 1040 of Location 16 (Plan 2568) and onwards to terminate at a line in prolongation southwestward of the westernmost northwestern boundary of Lot 1049 of Location 16 (Plan 2568).

(d) Part of Bickley Road to Boyle Lane; being that portion of Road No. 3409 commencing at the northwestern side of Maddington Road and extending generally westward along the northwestern boundaries of Lot 483 of Canning Location 13 (Land Titles Office Plan 3552) and the northern boundaries of Lots 7 (Diagram 25769), 6 (Diagram 15625), 305 (Plan 3327) and 1 (Diagram 49671), all of Location 13 to terminate at a line joining the northwestern corner of the last mentioned lot and the southwestern corner of Lot 5 of Location 13 (Diagram 16264).

(e) Part of Kenwick Road to Dale Place; being that portion of Road No. 185 commencing at a line joining the southwestern corner of Lot 323 of Canning Location 13 (Land Titles Office Plan 3327) and the northwestern corner of Lot 4 of Location 13 (Diagram 19029) and extending northeastward along the southeastern boundaries of Lots 323, 324, 325 and 326 (Plan 3327), and 10 and 11 (Diagram 52958) all of Location 13 to terminate at the southwestern side of White Road (Road No. 3471).

(Public Plans Perth 2 000 21.09; 22.10; 22.13; 22.15; 22.16; 23.13 and 23.16.)

## CHANGE OF NAME OF STREET.

City of Stirling.

Department of Lands and Surveys,  
Perth, 4 September 1981.

File No. 317/68.

IT is hereby notified for general information that His Excellency the Governor in Executive Council has been pleased to approve under section 10 of the Land Act 1933 of the change of name of Waldemar Street to Waldemar Street; being the whole of the surveyed road commencing at the western side of Valance Way and extending westward along the northern boundary of Lots 76 to 89 inclusive (Land Titles Office Plan 9119) and 31 (Plan 13466) all of Perthshire Location A<sup>t</sup> thence southwestward along the northwestern boundary of Lots 32 to 35 inclusive (Plan 13466) of the said Location to terminate at the northeastern side of Wanstead Street.

(Public Plan Perth 2 000 09.33.)

B. L. O'HALLORAN,  
Under Secretary for Lands.

## CHANGE OF NAME OF STREET.

Shire of Boulder.

Department of Lands and Surveys,  
Perth, 4 September 1981.

File No. 2154/70.

IT is hereby notified for general information that His Excellency the Governor in Executive Council has been pleased to approve, under section 10 of the Land Act 1933, of the change of name of Wilson Street to Lionel Street; being that portion of Road No. 854 commencing at the southwestern corner of the southwestern severance of Boulder Lot 2353 and extending northward along the western boundary of the said severance and onward to terminate at a line in prolongation northwestward of the northeastern boundary of the said severance.

(Public Plans Kalgoorlie-Boulder 30.35 and 30.36.)

B. L. O'HALLORAN,  
Under Secretary for Lands.

## CHANGE OF NAME OF STREET.

Shire of Carnarvon.

Department of Lands and Surveys,  
Perth, 4 September 1981.

File No. 2982/57, V2.

IT is hereby notified for general information that His Excellency the Governor in Executive Council has been pleased to approve, under section 10 of the Land Act 1933 of the change of name of Meiklejohn Crescent to Newman Place; being the whole of the surveyed road commencing at the southwestern side of Richards Street and extending southwestward along the northwestern boundaries of Lot 11 of Carnarvon Lot 1185 (Land Titles Office Diagram 46212) and the northwestern boundaries of Lots 310, 311 and 312 of Carnarvon Lot 1179 (Plan 13124) to terminate at a line joining the northwestern corner of the lastmentioned lot and the southwestern corner of Lot 330 of Carnarvon Lot 1179, (Plan 13124).

(Public Plan Carnarvon 8.06.)

B. L. O'HALLORAN,  
Under Secretary for Lands.

## CHANGE OF NAME OF STREET.

Shire of Narembeen.

Department of Lands and Surveys,  
Perth, 4 September 1981.

File No. 4569/74.

IT is hereby notified for general information that His Excellency the Governor in Executive Council has been pleased to approve, under section 10 of the Land Act 1933 of the change of name of Cheetams Road to Cheethams Road as shown in green on Miscellaneous Plan No. 794.

(Public Plans Babakin 1 : 50 000, Narembeen 1 : 50 000.)

B. L. O'HALLORAN,  
Under Secretary for Lands.

## CHANGE OF NAME OF STREET.

Shire of West Arthur.

Department of Lands and Surveys,  
Perth, 4 September 1981.

File No. 2077/71.

IT is hereby notified for general information that His Excellency the Governor in Executive Council has been pleased to approve, under section 10 of the Land Act 1933 of the change of name of Ualling Crossing Road to Eulin Crossing Road, as shown in green on Miscellaneous Plan No. 686.

(Public Plans Blackwood River SW &amp; SE 1 : 25 000.)

B. L. O'HALLORAN,  
Under Secretary for Lands.

## LAND ACT 1933.

Land Release.

Department of Lands and Surveys,  
Perth, 4 September 1981.

File No. 2850/980.

APPLICATIONS are invited under section 45A of the Land Act 1933, for the purchase in fee simple of Canning Location 3232 by adjoining holders only at the purchase price of two hundred dollars (\$200.00).

Applications, accompanied by \$200 must be lodged at the Department of Lands and Surveys, Perth, on or before Wednesday, 9 September 1981.

All applications lodged on or before the closing date will be treated as having been received on that date, and if there are more applications than one for the location, the application to be granted will be decided by the Land Board.

(Plan Perth 2 000 17.23 (Armada Road).)

B. L. O'HALLORAN,  
Under Secretary for Lands.

## LAND ACT 1933.

Land Release.

Department of Lands and Surveys,  
Perth, 4 September 1981.

File No. 132/53, V2.

HIS Excellency the Governor in Executive Council has been pleased to approve under section 45A of the Land Act 1933, of Derby Lot 689 being made available for sale in fee simple at the purchase price of four thousand one hundred dollars (\$4 100.00) and subject to the payment for improvements at valuation, in cash, should the successful applicant be other than the former lessee.

Applications must be lodged at the Department of Lands and Surveys, Perth.

(Plan Derby 2 000 CK75/04.04; 04.05 (Fitzroy Street).)

B. L. O'HALLORAN,  
Under Secretary for Lands.

## LAND ACT 1933.

Land Release.

Department of Lands and Surveys,  
Perth, 4 September 1981.

File No. 2298/74.

HIS Excellency the Governor in Executive Council has been pleased to approve under section 45A of the Land Act 1933, of Kununurra Lot 1123 being made available for sale in fee simple at the purchase price of one thousand nine hundred and seventy-five dollars (\$1 975.00) and subject to the payment for improvements at valuation, in cash, should the successful applicant be other than the former lessee.

Applications must be lodged at the Department of Lands and Surveys, Perth.

(Plan Kununurra 2 000 23.16 (Ivanhoe Road).)

B. L. O'HALLORAN,  
Under Secretary for Lands.

## LAND ACT 1933.

## Land Release.

Department of Lands and Surveys,  
Perth, 4 September 1981.

File No. 4070/66.

HIS Excellency the Governor in Executive Council has been pleased to approve under section 45A of the Land Act 1933, of Leeman Lot 111 being made available for sale in fee simple at the purchase price of two thousand dollars (\$2 000.00) and subject to the payment for improvements at valuation, in cash, should the successful applicant be other than the former lessee.

Applications must be lodged at the Department of Lands and Surveys, Perth.

(Plan Leeman 2 000 39.06 (Morcombe Road).)

B. L. O'HALLORAN,  
Under Secretary for Lands.

## LAND ACT 1933.

## Land Release.

Department of Lands and Surveys,  
Perth, 4 September 1981.

File No. 4950/25.

HIS Excellency the Governor in Executive Council has been pleased to approve under section 45A of the Land Act 1933 of Pemberton Lot 238 being made available for sale in fee simple at the purchase price of one dollar (\$1.00) and subject to the payment for improvements at valuation, in cash, should the successful applicant be other than the owner of such improvements.

Applications must be lodged at the Department of Lands and Surveys, Perth.

(Plan Pemberton Townsite (Jamieson Street).)

B. L. O'HALLORAN,  
Under Secretary for Lands.

## LAND ACT 1933.

## Land Release.

Department of Lands and Surveys,  
Perth, 4 September 1981.

File No. 1873/76.

HIS Excellency the Governor in Executive Council has been pleased to approve under section 45A of the Land Act 1933, of Port Denison Lot 222 being made available for sale in fee simple at the purchase price of three thousand dollars (\$3 000.00) and subject to the payment for improvements at valuation, in cash, should the successful applicant be other than the former lessee.

Applications must be lodged at the Department of Lands and Surveys, Perth.

(Plan Port Denison 2 000 34.40 (Duval Street).)

B. L. O'HALLORAN,  
Under Secretary for Lands.

## LAND ACT 1933.

## Land Release.

Department of Lands and Surveys,  
Perth, 4 September 1981.

Corres. 3079/68, V.7.

APPLICATIONS are invited under section 45A of the Land Act 1933, for the purchase in fee simple of Karratha Lot 3804 containing an area of 1 191 square metres for the purpose of "Local Shops" at the purchase price of \$30 000.

Intending applicants shall submit with their applications:

- (a) Detailed plans of the proposed development to be in compliance with the Town Planning Regulations and Building By-laws as administered by the Shire of Roebourne with particular reference to provision of parking, use of suitable building materials and landscaping

proposals. The retail floor space of each shop to be less than 92.9 square metres, unless otherwise approved by the Minister for Lands.

- (b) Details of timing of the proposed development programme including details of staging where proposed, as from the date of allocation of the site.
- (c) Details of cost estimates, related to stages of development.
- (d) Details of source/s of funds.
- (e) Details of any previous experience in the development and/or management of similar projects.

The lot is made available subject to the following conditions:—

- (1) The Minister for Lands reserves the right to refuse any application on the grounds that the proposed development and/or development programme is inadequate or unsuitable or that the applicant has failed to show adequate capacity to fund his development programme.
- (2) On payment of the first instalment of purchase money a licence will be available upon which a mortgage can be registered. A Crown Grant (freehold) will not issue until the purchaser has complied with the building requirements as defined.
- (3) Prior to the commencement of construction the Minister shall advise the purchaser of the extent of development that will be necessary to enable the issue of a Crown Grant (freehold).
- (4) The purchaser shall within the six months next following the date of approval of the sale of the land commence to erect or construct or cause the erection or construction to be commenced and will thereafter diligently proceed with and complete or cause to be completed within the two years next following the date of approval of the sale the erection or construction on the said land of premises designed and constructed for the specific business of the purchaser. If this condition has not been complied with in the time prescribed the land may be absolutely forfeited together with all the purchase money and fees that may have been paid.

Subject to agreement between the purchaser and the Minister, the foregoing development obligations and other conditions set out herein may be varied or added to from time to time.

A deposit of 10% of the purchase price is payable on application and the balance of purchase money shall be paid within twelve months of the date of approval of application by four (4) quarterly instalments on the first days of January, April, July and October in each year. The first instalment of purchase money shall become due and payable on the first day of the quarter next following the date of approval of application, the Crown Grant fee being payable with the last instalment of purchase money: Nothing shall prevent the balance of purchase money and fees being paid at an earlier date should the purchaser so desire, but a Crown Grant shall not issue until the conditions under which the lot was made available for sale have been fulfilled.

A person in the employ of the State must apply through the Under Secretary for Lands for the Governor's permission to hold this land. Written approval of the Permanent Head concerned should accompany such application.

Applications, accompanied by a deposit of \$3 000 must be lodged at the Department of Lands and Surveys, Perth on or before Wednesday 21 October 1981, together with the required development details and completed Land Board questionnaire.

All applications lodged on or before the closing date will be treated as having been received on that date, and if there are more applications than one for the lot, the application to be granted will be decided by the Land Board.

(Plan Karratha 2 000 29.27 (Gawthorne Drive).)

B. L. O'HALLORAN,  
Under Secretary for Lands.



## APPLICATION FOR LEASING.

Department of Lands and Surveys,  
Perth, 4 September 1981.

Corres. 828/73, V.3.

APPLICATIONS are invited under section 117 of the Land Act 1933 for the leasing of the Karratha lots shown in the schedule for the purpose of "Service Trades" for a term of 21 years at the annual rentals shown in the said schedule.

Uses which may be permitted on a service trades lot include sale yards, showroom, stores, repair and servicing workshops, display areas, veterinary clinics, taxi depot and the like. Under the provisions of an Agreement with Farmers Stores of W.A., sites for retail purposes can be restricted to new and secondhand vehicle sales, motor parts and accessories, building materials and agricultural, mining and industrial machinery. It is also necessary for uses to conform with development standards set for the Town Centre. It is essential, therefore, that applicants note the following special release conditions.

Intending applicants shall submit with their applications details of intended utilisation and proposed development indicating size and type of intended structures, cost estimates, source of funds and programme for construction whether staged or not.

The Minister for Lands reserves the right to refuse any application on the grounds that the proposed utilisation, development and/or development programme is inadequate or unsuitable or that the applicant has failed to show adequate capacity to fund the development.

The development of "Factoryettes" for the purpose of sub-leasing will be permitted on these lots subject to satisfactory proposals being submitted in accordance with the requirements of paragraphs 2, 3 and 4 above.

A Land Board (acting as a board of enquiry) will be appointed to assess all applications received.

The services provided to these lots are Roads, Water and Power and the Service Premium, as shown in the schedule, is payable in four (4) equal quarterly instalments, payable in January, April, July and October. The first instalment is due and payable on the first day of the quarter next following the date of approval of the lease.

The survey fee shown in the schedule is payable in cash within 30 days of acceptance of application.

Where the in-going lessee indicates that he anticipates a requirement for freehold during the currency of the lease, the Hon. Minister shall signify the extent of development (which may be additional to that required as the basis for leasing the site) that will be necessary to enable the issue of a Crown Grant.

Subject to agreement between the lessee and the Minister, the foregoing development obligations and other conditions set out herein may be varied or added to from time to time.

At any time during the currency of the lease, subject to the agreed development obligations and other conditions having been met to the satisfaction of the Hon. Minister, the lessee may surrender his lease to the intent that he may apply for purchase of the said land.

In the event of the lessee surrendering his lease and becoming the successful applicant for purchase of the said land, a purchase price in accordance with the schedule shall apply for a period of 3 years from the date of approval of his lease (following which period the price shall be subject to review) and fees associated with the issue of a Crown Grant shall be payable.

The land is made available for leasing subject to the following conditions:—

- (1) The land shall not be used for any purpose other than the approved Service Trades purpose.
- (2) The rent shall be subject to reappraisal at the end of the third year and each successive three year period thereafter.
- (3) The lessee shall not without the previous consent in writing of the Minister for Lands assign, transfer, mortgage, sublet or part with the possession of the demised land.

- (4) The land shall be occupied and used by the lessee for the purpose specified within nine (9) months of the commencement of the lease and thereafter will be continuously so used to the satisfaction of the Minister.
- (5) The lessee shall commence construction within nine (9) months and thereafter continue construction and complete and operate the works within two (2) years from the date of the commencement of the lease.
- (6) All buildings, erections, paving, drainage and other works shall be to the approval of the Local Authority and the lessee shall perform, discharge and execute all requisitions and works unto the demised land as are or may be required by any local or public authority operating under any statute by-law or regulation.
- (7) The lessee shall, within twelve months from commencement of the lease, fence the external boundaries to the satisfaction of the Minister.
- (8) The lessee shall maintain existing and future improvements to the satisfaction of the Minister for Lands.
- (9) All frontages shall be treated and maintained to give an appearance aesthetically pleasing consistent with the purpose of the lease according to a plan submitted to the Minister for Lands.
- (10) The lessee shall indemnify the Minister against all claims for damage to property or persons arising from the use of the land.
- (11) The Minister or his representative may enter the land for inspection at any reasonable time.
- (12) The land shall be filled to levels specified by, and acceptable to the Minister or his nominee and the Shire Council.
- (13) The lessee shall not apply for a licence to sell liquor without the prior written consent of the Minister. In the event of the granting of such a licence the rent shall be subject to immediate reappraisal.
- (14) The lessee shall comply with all conditions imposed by the Department of Transport.
- (15) The lessee shall at his own expense install and maintain fire-fighting and control equipment to the approval of the Minister.
- (16) Compensation will not be payable for damage by flooding of the demised land.
- (17) Compensation shall not be payable to the lessee in respect of any improvements effected by him on the demised land and remaining thereon at the expiration or earlier determination of the lease.
- (18) It shall be lawful for the lessee at any time within the three calendar months immediately following the expiration of the term or earlier determination of the lease, to take down, remove, and carry away any buildings, structures, improvements and plant the property of the lessee.
- (19) On determination of the lease, the lessee shall fill in, consolidate and level off any unevenness, excavation or hole caused by him during the term of the lease or by removal of his improvements and shall leave the demised land in a clean, neat and tidy condition to the satisfaction of the Minister for Lands and shall remove any or all waste matter as required by the Minister.

A person in the employ of the State must apply through the Under Secretary for Lands for the Governor's permission to hold this land. Written approval of the Permanent Head concerned should accompany such application.

Applications must be lodged at the Department of Lands and Surveys, Perth on or before Wednesday, 21 October 1981 accompanied by the deposit shown in the schedule together with the required development details and completed Land Board questionnaire.

## Schedule.

Lot; Street; Area; Survey Fee; Service Premium; Purchase Price; Annual Rental; Deposit.
1955; Warambie Road; 4 351 m <sup>2</sup> ; \$190; \$66 135; \$7 220; \$580; \$320.
1977; Sherlock Cres; 740 m <sup>2</sup> ; \$120; \$11 248; \$2 890; \$230; \$145;
1978; Sherlock Cres; 789 m <sup>2</sup> ; \$120; \$11 993; \$2 950; \$235; \$147.50.
1979; Sherlock Cres; 1 116 m <sup>2</sup> ; \$130; \$16 963; \$3 340; \$270; \$165.
1980; Sherlock Cres; 1 265 m <sup>2</sup> ; \$130; \$19 228; \$3 520; \$280; \$170.
1981; Sherlock Cres; 798 m <sup>2</sup> ; \$120; \$12 130; \$2 960; \$240; \$150.
1982; Sherlock Cres; 763 m <sup>2</sup> ; \$120; \$11 598; \$2 920; \$235; \$147.50.
1983; Sherlock Cres; 913 m <sup>2</sup> ; \$120; \$13 878; \$3 100; \$250; \$155.
1984; Sherlock Cres; 903 m <sup>2</sup> ; \$120; \$13 726; \$3 080; \$250; \$155.
2662; Morse Court; 2 552 m <sup>2</sup> ; \$170; \$38 790; \$5 060; \$405; \$232.50.

(Plans Karratha Townsite 30.27 and 30.28.)

B. L. O'HALLORAN,  
Under Secretary for Lands.

Subject to agreement between the lessee and the Minister, the foregoing development obligations and other conditions set out herein may be varied or added to from time to time.

At any time during the currency of the lease, subject to the agreed development obligations and other conditions having been met to the satisfaction of the Hon. Minister, the lessee may surrender his lease to the intent that he may apply for purchase of the said land.

In the event of the lessee surrendering his leave and becoming the successful applicant for the purchase of the said land, a purchase price in accordance with the Schedule shall apply for a period of 3 years from the date of approval of his lease (following which period the price shall be subject to review) and fees associated with the issue of a Crown Grant shall be payable.

The land is made available for leasing subject to the following conditions:—

- (1) The land shall not be used for any purpose other than "Light Industry" without the prior approval in writing of the Minister for Lands.
- (2) The rent shall be subject to reappraisal at the end of the third year and each successive three year period thereafter.
- (3) The lessee shall not without the previous consent in writing of the Minister for Lands assign, transfer, mortgage sublet or part with the possession of the demised land.
- (4) The land shall be occupied and used by the lessee for the purpose specified within nine (9) months of the commencement of the lease and thereafter will be continuously so used to the satisfaction of the Minister.
- (5) The lessee shall commence construction within nine (9) months and thereafter continue construction and complete and operate the works within two (2) years from the date of the commencement of the lease.
- (6) All buildings, erections, paving, drainage and other works shall be to the approval of the Local Authority and the lessee shall perform, discharge and execute all requisitions and works unto the demised land as are or may be required by any local or public authority operating under any statute by-law or regulation.
- (7) The lessee shall, within twelve months from commencement of the lease, fence the external boundaries with Industrial Fencing to the satisfaction of the Minister.
- (8) The lessee shall maintain existing and future improvements to the satisfaction of the Minister for Lands.
- (9) All frontages shall be treated and maintained to give an appearance aesthetically pleasing consistent with the purpose of the lease according to a plan submitted to the Minister for Lands.
- (10) The lessee shall indemnify the Minister against all claims for damage to property or persons arising from the use of the land.
- (11) The Minister or his representative may enter the land for inspection at any reasonable time.
- (12) The land shall be filled to levels specified by, and acceptable to the Minister or his nominee and the Shire Council.
- (13) Compensation will not be payable for damage by flooding of the demised land.
- (14) Compensation shall not be payable to the lessee in respect of any improvements effected by him on the demised land and remaining thereon at the expiration or earlier determination of the lease.
- (15) It shall be lawful for the lessee at any time within the three calendar months immediately following the expiration of the term or earlier determination of the lease, to take down, remove, and carry away any buildings, structures, improvements and plant the property of the lessee.

## APPLICATION FOR LEASING.

Department of Lands and Surveys,  
Perth, 4 September 1981.

Corres. 404/69, V3.

APPLICATIONS are invited under section 117 of the Land Act, 1933 for the leasing of the Karratha Lots shown in the schedule for the purpose of "Light Industry" for a term of 21 years at the annual rentals shown in the said schedule.

Intending applicants shall submit with their applications details of intended utilisation and proposed development indicating size and type of intended structures, cost estimates, source of funds and programme for construction whether staged or not.

The Minister for Lands reserves the right to refuse any application on the grounds that the proposed utilisation, development and/or development programme is inadequate or unsuitable or that the applicant has failed to show adequate capacity to fund the development.

The services provided to these lots are Water, Electricity, Drainage and Roads and the Service Premium as shown in the schedule is payable in four (4) equal quarterly instalments in January, April, July and October. The first instalment is due and payable on the first day of the quarter next following the date of approval of the lease.

The survey fees shown in the schedule are payable in cash within 30 days of acceptance of application.

Lot 2542 will require the construction of an access culvert to the specifications of the Main Roads Department at a cost of about \$2 000. Applicants should contact the Main Roads Department in this regard.

The successful applicants will be required to comply with the established floor levels of buildings, and should contact the local authority in order to ascertain its requirements.

The development of "Factoryettes" for the purpose of sub-leasing will be permitted on Lots 2530, 2873-2876 and 2879-2883 subject to satisfactory proposals being submitted in accordance with the requirements of paragraphs 2 and 3 above.

Where the in-going lessee indicates that he anticipates a requirement for freehold during the currency of the lease, the Hon. Minister shall signify the extent of development (which may be additional to that required as the basis for leasing the site) that will be necessary to enable the issue of a Crown Grant.

(16) On determination of the lease, the lessee shall fill in, consolidate and level off any unevenness, excavation or hole caused by him during the term of the lease or by removal of his improvements and shall leave the demised land in a clean, neat and tidy condition to the satisfaction of the Minister for Lands and shall remove any or all waste matter as required by the Minister.

A person in the employ of the State must apply through the Under Secretary for Lands for the Governor's permission to hold this land. Written approval of the Permanent Head concerned should accompany such application.

Applications must be lodged at the Department of Lands and Surveys, Perth on or before Wednesday 21 October 1981 accompanied by the deposit shown in the schedule together with the required development details and completed Land Board questionnaire.

All applications lodged on or before that date will be treated as having been received on the closing date, and if there are more applications than one for any lot, the application to be granted will be decided by the Land Board.

#### Schedule.

Lot; Street; Area; Survey Fee; Service Premium; Purchase Price; Annual Rental; Deposit.
1970; Anderson Road; 5 773 m <sup>2</sup> ; \$70; \$11 460; \$3 990; \$320; \$190.
2489; Pemberton Way; 1.344 7 ha; \$90; \$26 890; \$6 690; \$535; \$297.50.
2490; Pemberton Way; 9 786 m <sup>2</sup> ; \$90; \$19 570; \$5 900; \$470; \$265.
2 492; Pemberton Way; 8 410 m <sup>2</sup> ; \$90; \$16 820; \$5 250; \$420; \$240.
2 503; Fisher Way; 3 676 m <sup>2</sup> ; \$60; \$7 350; \$3 030; \$240; \$150.
2504; Fisher Way; 3 247 m <sup>2</sup> ; \$60; \$6 490; \$2 830; \$230; \$145.
2510; Fisher Way; 1 991 m <sup>2</sup> ; \$60; \$3 980; \$2 240; \$180; \$120.
2511; Coolawanyah Road; 5 861 m <sup>2</sup> ; \$70; \$11 720; \$4 050; \$320; \$190.
2512; McKay Street; 2 420 m <sup>2</sup> ; \$60; \$4 840; \$2 440; \$200; \$130.
2513; McKay Street; 2 470 m <sup>2</sup> ; \$60; \$4 940; \$2 460; \$200; \$130.
2515; McKay Street; 2 470 m <sup>2</sup> ; \$60; \$4 940; \$2 460; \$200; \$130.
2528; Cowle Road; 1.385 7 m <sup>2</sup> ; \$90; \$27 710; \$6 770; \$540; \$300.
2529; Augustus Drive; 7 558 m <sup>2</sup> ; \$70; \$15 120; \$4 850; \$390; \$220.
2530; Augustus Drive; 6 006 m <sup>2</sup> ; \$70; \$12 010; \$4 120; \$330; \$195.
2542; Coolawanyah Road; 8 858 m <sup>2</sup> ; \$90; \$17 720; \$5 460; \$440; \$250.
2873; Cowle Road; 3 870 m <sup>2</sup> ; \$60; \$7 740; \$3 120; \$250; \$155.
2874; Cowle Road; 3 800 m <sup>2</sup> ; \$60; \$7 600; \$3 090; \$250; \$155.
2875; Cowle Road; 3 800 m <sup>2</sup> ; \$60; \$7 600; \$3 090; \$250; \$155.
2876; Cowle Road; 4 469 m <sup>2</sup> ; \$70; \$8 940; \$3 400; \$270; \$165.
2878; Coolawanyah Road; 6 890 m <sup>2</sup> ; \$70; \$13 780; \$4 540; \$360; \$210.
2879; Pemberton Way; 4 500 m <sup>2</sup> ; \$70; \$9 000; \$3 420; \$270; \$165.
2881; Pemberton Way; 4 754 m <sup>2</sup> ; \$70; \$9 510; \$3 530; \$280; \$170.
2882; Pemberton Way; 4 447 m <sup>2</sup> ; \$70; \$8 890; \$3 390; \$270; \$165.
2883; Pemberton Way; 4 851 m <sup>2</sup> ; \$70; \$9 700; \$3 580; \$290; \$175.
2884; Pemberton Way; 4 750 m <sup>2</sup> ; \$70; \$9 500; \$3 530; \$280; \$170.
2885; Coolawanyah Road; 4 750 m <sup>2</sup> ; \$70; \$9 500; \$3 530; \$280; \$170.

2886; Coolawanyah Road; 4 750 m<sup>2</sup>; \$70; \$9 500; \$3 530; \$280; \$170.

2888; Coolawanyah Road; 4 225 m<sup>2</sup>; \$70; \$8 450; \$3 290; \$260; \$160.

2889; Pemberton Way; 4 225 m<sup>2</sup>; \$70; \$8 450; \$3 290; \$260; \$160.

2 890; Pemberton Way; 3 800 m<sup>2</sup>; \$70; \$7 600; \$3 090; \$250; \$155.

2891; Pemberton Way; 4 750 m<sup>2</sup>; \$70; \$9 500; \$3 530; \$280; \$170.

(Plans Karratha Townsite 32.23, 32.24, 32.25, and 33.24.)

B. L. O'HALLORAN,  
Under Secretary for Lands.

#### APPLICATION FOR LEASING.

Department of Lands and Surveys,  
Perth, 4 September 1981.

Corres. 719/981.

APPLICATIONS are invited under section 117 of the Land Act 1933, for the leasing of Port Hedland Lot 5408 containing an area of about 7 000 square metres for the purpose of "Boarding Kennels" for a term of 21 years at a rental of \$335.00 per annum.

Intending applicants shall submit with their applications details of intended utilisation and proposed development indicating size and type of intended structures, cost estimates, source of funds and programme for construction whether staged or not.

The Minister for Lands reserves the right to refuse any application on the grounds that the proposed utilisation, development and/or development programme is inadequate or unsuitable or that the applicant has failed to show adequate capacity to fund the development.

The land is made available for leasing subject to the following conditions:—

- (1) The land shall not be used for any purpose other than "Boarding Kennels" without the prior approval in writing of the Minister for Lands.
- (2) The rent shall be subject to reappraisal at the end of the third year and each successive three year period thereafter.
- (3) The lessee shall pay cost of survey when called upon.
- (4) The lessee shall not without the previous consent in writing of the Minister for Lands assign, transfer, mortgage, sublet or part with the possession of the demised land.
- (5) The land shall be occupied and used by the lessee for the purpose specified within nine (9) months of the commencement of the lease and thereafter will be continuously so used to the satisfaction of the Minister.
- (6) The lessee shall commence construction within nine (9) months and thereafter continue construction and complete and operate the works within two (2) years from the date of the commencement of the lease.
- (7) All buildings, erections, paving, drainage and other works shall be to the approval of the Local Authority and the lessee shall perform, discharge and execute all requisitions and works unto the demised land as are or may be required by any local or public authority operating under any statute, by-law or regulation.
- (8) The lessee shall, within twelve months from commencement of the lease, fence the external boundaries with a security fence to the satisfaction of the Minister.
- (9) The lessee shall maintain existing and future improvements to the satisfaction of the Minister for Lands.
- (10) All frontages shall be treated and maintained to give an appearance aesthetically pleasing consistent with the purpose of the lease according to a plan submitted to the Minister for Lands.

- (11) The only residence permitted will be that of the Lessee or a Manager or Manager/Caretaker.
- (12) The lessee shall indemnify the Minister against all claims for damage to property or persons arising from the use of the land.
- (13) The Minister or his representative may enter the land for inspection at any reasonable time.
- (14) The land shall be filled to levels specified by and acceptable to the Minister or his nominee and the Shire Council.
- (15) The lessee shall comply with all conditions imposed by the Department of Transport.
- (16) Compensation will not be payable for damage by flooding of the demised land.
- (17) Compensation shall not be payable to the lessee in respect of any improvements effected by him on the demised land and remaining thereon at the expiration or earlier determination of the lease.
- (18) It shall be lawful for the lessee at any time within the three calendar months immediately following the expiration of the term or earlier determination of the lease, to take down, remove and carry away any buildings, structures, improvements and plant the property of the lessee.
- (19) On determination of the lease, the lessee shall fill in, consolidate and level off any unevenness, excavation or hole caused by him during the term of the lease or by removal of his improvements and shall leave the demised land in a clean, neat and tidy condition to the satisfaction of the Minister for Lands and shall remove any or all waste matter as required by the Minister.

A person in the employ of the State must apply through the Under Secretary for Lands for the Governor's permission to hold this land. Written approval of the Permanent Head concerned should accompany such application.

Applications must be lodged at the Department of Lands and Surveys, Perth, on or before Wednesday, 21 October 1981, accompanied by a deposit of \$197.50 together with the required development details and completed Land Board Questionnaire.

All applications lodged on or before that date will be treated as having been received on the closing date, and if there are more applications than one for the lot, the application to be granted will be decided by the Land Board.

(Plan Port Hedland Regional 6.6.)

B. L. O'HALLORAN,  
Under Secretary for Lands.

#### LOCAL GOVERNMENT ACT 1960-1981.

##### Closure of Streets.

WHEREAS The Commonwealth of Australia, being the owner of the land which adjoins the street hereunder described has agreed to the request of the City of Perth to close the said street.

Perth.

File No. 1313/72. P. 730. All that portion of Baillie Avenue as shown bordered blue on Lands and Surveys Diagram 84494. (Public Plan Perth 2 000 16.20.)

WHEREAS Dean Edward Parker, Patricia Joan Parker, Morton Farms Pty. Ltd., Fenwick Dean Aynsley and Pamela Mary Aynsley, being the owners of the land which adjoins the street hereunder described have agreed to the request of the Shire of Beverley to close the said street.

Beverley.

File No. 89/11. B. 1044.

- (i) All that portion of Road No. 4129, along the northeastern boundaries of Avon Locations 5471 and 10859; from the southeastern side of Cludlow Road to the northwestern side of Batys Road (Road No. 3861).

- (ii) All that portion of Surveyed road, along the southern boundary of Avon Location 18672; from a line in prolongation southward of the western boundary of the said Location 18572 to a line in prolongation southeastward of its northeastern boundary.

(Public Plan Quajabin 1:50 000.)

WHEREAS William Francis Brogan, being the owner of the land which adjoins the street hereunder described has agreed to the request of the Shire of Carnarvon to close the said street.

Carnarvon.

File No. 1756/77.

C. 1017.

- (a) All that portion of French Street shown bordered blue on Original Plan 15007.
- (b) All that portion of French Street now comprised in Mauds Landing Lot 47 surveyed and shown on Original Plan 15007.

(Public Plan Mauds Landing Townsite.)

The notice published in the *Government Gazette* dated 29 May 1981, page 1630 under the heading of "Carnarvon" is hereby superseded.

WHEREAS Lomas Theodore Toovey, being the owner of the land which adjoins the street hereunder described has agreed to the request of the Shire of Cranbrook to close the said street.

Cranbrook.

File No. 1073/79.

C. 1024. All those portions of Road No. 2928, Road No. 1044 and Road No. 1045 as shown bordered blue on Original Plan 14903. (Public Plan Uannup S E 1:25 000 and Warranup S W 1:25 000.)

WHEREAS Thomas William Underwood and Moreton Harslett, being the owners of the land which adjoins the street hereunder described have agreed to the request of the Shire of Dundas to close the said street.

Dundas.

File No. 1290/981.

D. 651. The whole of the surveyed way along the southern boundary of Noresman Lot 311; from a line in prolongation southward of the western boundary of the said lot to the western side of Angove Street. (Public Plan Norseman Townsite Sheet 3.)

WHEREAS Alistair Garry McDonald, being the owner of the land which adjoins the street hereunder described has agreed to the request of the Shire of Lake Grace to close the said street.

Lake Grace.

File No. 1071/79.

L. 108. All that portion of Dawson Road shown bordered blue on Original Plan 14694. (Public Plan Newdegate 1:50 000.)

WHEREAS A and B Barnett Nominees Pty. Ltd., being the owner of the land which adjoins the street hereunder described has agreed to the request of the Shire of Merredin to close the said street.

Merredin.

File No. 3603/78.

M. 1039. The whole of the road along the southern boundary of Jilbadji Location 149; from the northernmost northeastern boundary of Location 159 to a line in prolongation southward of the eastern boundary of Location 149. (Public Plan 24/80 E3.)

WHEREAS Ian Stewart Webster, Christine Ethel Webster, and Paul Henning Metz, being the owners of the land which adjoins the street hereunder described have agreed to the request of the Shire of Ravensthorpe to close the said street.

## Ravensthorpe.

File No. 6219/02, V.2.

R. 153.

- (a) The whole of the surveyed road, along the western and southern boundaries of MHL 327 and the southern boundary of MHL 5; from the southern boundary of MHL 41 to the northwestern side of Road No. 2658.
- (b) All that portion of Road No. 6587 along the eastern boundary of the southern severance of Oldfield Location 68, the eastern boundary of Location 69 and the eastern boundary of Location 649; from a line in prolongation northeastward of the northernmost northwestern boundary of the said severance to the northwestern side of Manyutup Road.
- (c) The whole of the surveyed road, along the eastern boundaries of MHL 95 and Oldfield Location 22; from the southwestern side of Jerramungup-Ravensthorpe Road to a line in prolongation eastward of the southern boundary of Location 22.
- (d) The whole of the surveyed road, along the northern boundaries of Oldfield Location 193 and 27, through Location 71 and along the northern boundaries of MHL 200 and MHL 124; from the eastern boundary of Location 26 to a line in prolongation northward of the eastern boundary of MHL 124.
- (e) The whole of the surveyed road, along the western boundary of Oldfield Location 649; from a line in prolongation southwestward of the northwestern boundary of the said location to a northwestern side of Manyutup Road.
- (f) The whole of the surveyed road along the western boundary of Oldfield Location 263; from the southeastern side of Manyutup Road to a line in prolongation westward of the southern boundary of the above location.

(Public Plans 420/80 and 420 B/20.)

WHEREAS Minister for Lands, being the owner of the land which adjoins the street hereunder described has agreed to the request of the Shire of Roebourne to close the said street.

## Roebourne.

File No. 649/980.

R. 154.

- (a) All that portion of Millars Road (Road No. 15445) as shown bordered blue on Original Plan 15011.
- (b) All that portion of Millars Road (Road No. 15445) commencing from the northeastern side of Balmoral Road (Original Plan 15011) and extending southeastward through vacant Crown land to terminate at the northwestern side of Balmoral Road (Original Plan 14698).

(Public Plans Karratha Townsite 28.27, 28.28, 29.27.)

WHEREAS Hamersley Iron Pty Limited, being the owner of the land which adjoins the street hereunder described has agreed to the request of the Shire of Roebourne to close the said street.

## Roebourne.

File No. 3966/980.

R. 156.

- (a) All that portion of Road No. 4261, through Pastoral Lease 3114/464, Reserve 9701 and again through Pastoral Lease 3114/464 and Reserve 356; from the mouth of the Maitland River to the northwestern side of Road No. 15215.
- (b) All that portion of Road No. 283, through Pastoral Lease 3114/464, vacant Crown land and again through Pastoral Lease 3114/464; from the mouth of the Maitland River to the northwestern side of Road No. 15215.

WHEREAS James Thomas Maher, Richard Patrick Maher and Martindale Pty. Ltd., being the owners of the land which adjoins the street hereunder described has agreed to the request of the Shire of Victoria Plains to close the said street.

## Victoria Plains.

File No. 3018/73.

V.110. The whole of the surveyed road along the northern and northeastern boundaries of the southeastern severance of Lot M888 of Melbourne Location 935 (Office of Titles Diagram 3097) and through Lot M2042 of Location 935 (Office of Titles Plan 6156) but excluding the intersecting portion of Newdale Road; from the eastern side of Old Plains Road (Road No. 3051) to the northern side of Kargotich Road. (Public Plan 31/80 F1 & 2.)

And whereas the Council has requested closure of the said street; and whereas the Governor in Executive Council has approved this request; it is notified that the said street is hereby closed.

B. L. O'HALLORAN,  
Under Secretary for Lands.

## LOCAL GOVERNMENT ACT 1960-1981.

Department of Lands and Surveys,  
Perth, 4 September 1981.

IT is hereby declared that, pursuant to the resolution of the Town of Albany passed at a meeting of the Council held on or about 15 June, 1981 the undermentioned lands have been set apart, taken, or resumed under section 17 of the Public Works Act 1902, for the purpose of a new road, that is to say:—

## Albany.

3236/77 (R. 6491).

Road No. 16631 (Drew Lane) (Widening of Part). That portion of Lot 91 of Albany Suburban Lots 368 and 367 (Land Titles Office Plan 5724) as delineated and coloured dark brown on Original Plan 14844.

250 square metres being resumed from Lot 91 of Albany Suburban Lots 368 and 367.

(Public Plan Albany 2 000 12.05 and 12.06.)

IT is hereby declared that, pursuant to the resolution of the Shire of Albany passed at a meeting of the Council held on or about 4 March, 1981 the undermentioned lands have been set apart, taken, or resumed under section 17 of the Public Works Act 1902, for the purpose of a new road, that is to say:—

## Albany.

856/981 (R.6450).

Road No. 16671 (Redmond Road West). (i) A strip of land, 40 metres wide commencing from a line in prolongation northward of the western boundary of Plantagenet Location 6616 and extending as surveyed, generally eastward along portion of the southwestern boundary of Location 6612 and the southeastern boundaries of that location to terminate at a line in prolongation southward of the eastern boundary of the lastmentioned location.

(ii) (Widening of Part). That portion of Plantagenet Location 6612 as delineated and coloured dark brown on Lands and Surveys Diagram 84595.

281 square metres being resumed from Plantagenet Location 6612.

(Public Plan Redmond SE 1 : 25 000.)

IT is hereby declared that, pursuant to the resolution of the Shire of Kondinin passed at a meeting of the Council held on or about 18 February, 1980 the undermentioned lands have been set apart, taken, or resumed under section 17 of the Public Works Act 1902, for the purpose of a new road, that is to say:—

## Kondinin.

1783/54 (R.6367).

Road No. 12024 (Hyden Road North) (Deviation). A strip of land varying in width leaving the northeastern side of the present road and extending as delineated and coloured dark brown on Lands and Surveys Diagram 84125 northward through Roe Location 2127 to rejoin the southeastern side of the present road.

2.258 7 hectares being resumed from Roe Location 2127.

(Public Plan Hyden 1 : 50 000.)

IT is hereby declared that, pursuant to the resolution of the Shire of Goomalling passed at a meeting of the Council held on or about 9 January 1979 the undermentioned lands have been set apart, taken, or resumed under section 17 of the Public Works Act 1902, for the purpose of a new road, that is to say:—

## Goomalling.

4058/74 (R.6473).

Road No. 16685 (Morrell Road) (i) A strip of land 20.12 metres wide, commencing at the southeastern corner of Avon Location 9641 and extending as surveyed southwestward along the southeastern boundary of that location; thence northward along portion of the western boundary of the said location; thence westward along the southern boundary of Melbourne Location 1301; thence northward along portion of the western boundary of the lastmentioned location; thence westward along portion of the southern boundary of Location 1248; thence southward to and along the easternmost eastern boundary of Location 1953 and the eastern boundary of Location 2834 and onward to terminate at the northernmost northern boundary of the northern severance of Location 2151.

(ii) (Widenings and Deviations of Parts). Those portions of Avon Locations 12056, 13082 and 9641 and Melbourne Location 1301 as delineated and coloured dark brown on Original Plans 15047 and 15048.

(iii) (Extension). A strip of land, varying in width, commencing at the southern terminus of the present road at the northernmost northern boundary of the northern severance of Melbourne Location 2151 and extending as delineated and coloured dark brown on Original Plan 15047 southward and southwestward through that severance to terminate at the eastern side of a surveyed road at the westernmost western boundary of the said severance.

2.166 1 hectares being resumed from Melbourne Location 2151.

4 453 square metres being resumed from Melbourne Location 1301.

9 889 square metres being resumed from Avon Location 12056.

2 025 square metres being resumed from Avon Location 9641.

617 square metres being resumed from Avon Location 13082.

(Public Plan Mortlock River 25 000 NE.)

IT is hereby declared that, pursuant to the resolution of the Shire of Manjimup passed at meetings of the Council held on or about 1 December 1976 and 8 February 1978 the undermentioned lands have been set apart, taken, or resumed under section 17 of the Public Works Act 1902, for the purpose of a new road, that is to say:—

## Manjimup.

3995/77 (R.6464).

Road No. 3968 (Grays Road) (Widenings and Deviations of Parts). Those portions of Nelson Locations 9271 (State Forest No. 39) 3915 and 5008 and vacant Crown land as delineated and coloured dark and mid brown on Original Plan 14968.

State Forest No. 39 is hereby reduced by 816 square metres accordingly.

2 832 square metres being resumed from Nelson Location 3915.

416 square metres being resumed from Nelson Location 5008.

(Public Plan 442B/40 F2.)

IT is hereby declared that, pursuant to the resolution of the Shire of Roebourne passed at a meeting of the Council held on or about 12 December 1979 the undermentioned lands have been set apart, taken, or resumed under section 17 of the Public Works Act 1902, for the purpose of a new road, that is to say:—

## Roebourne.

782/73 (R. 6036).

Road No. 16312 A strip of land varying in width, commencing at the northwestern terminus of a surveyed road, within vacant Crown land and extending as delineated and coloured mid and dark brown on Lands and Surveys Diagram 80281 northwestward through vacant Crown land and De Witt Location 24 (Lease 3116/3469) to terminate as shown on the said diagram within the said location.

(Public Plan Dampier S.E. 1 : 25 000.)

IT is hereby declared that, pursuant to the resolution of the Shire of Swan passed at a meeting of the Council held on or about 19 June 1981 the undermentioned lands have been set apart, taken, or resumed under section 17 of the Public Works Act 1902, for the purpose of a new road, that is to say:—

## Swan.

2795/980 (R.6475).

Road No. 16687 (Dulwich Street) (i) A strip of land, 20.12 metres wide, commencing at a line in prolongation eastward of the southern boundary of Lot 618 of Swan Location 1 (Land Titles Office Plan 3698) and extending as surveyed northward along the eastern boundary of that lot to terminate at the southern side of a surveyed road (Harrow Street) at the northeastern corner of the said lot.

(ii) (Widening of Part) That portion of Swan Location 1 as delineated and coloured dark brown on Lands and Surveys Diagram 84356.

18 square metres being resumed from Swan Location 1.

(Public Plan Perth 2 000 19.36.)

IT is hereby declared that, pursuant to the resolution of the Shire of Wanneroo passed at a meeting of the Council held on or about 25 June 1980 the undermentioned lands have been set apart, taken, or resumed under section 17 of the Public Works Act 1902, for the purpose of a new road, that is to say:—

## Wanneroo.

2417/79 (R.6501).

Road No. 3 (Wanneroo Road) (Widenings of Parts) Those portions of Swan Locations 3211, 3709 (Reserve No. 21176) and 9471 (Reserve No. 834) as delineated and coloured dark brown on Original Plan 15021 and that portion of Lot 2 of Location 3211 as delineated and bordered green on Land Titles Office Diagram 58808.

Reserve No. 21176 is hereby reduced by 8 612 square metres and its area amended to 11.410 9 hectares accordingly.

Reserve No. 834 is hereby reduced by 8 822 square metres and its area amended to 27.903 6 hectares accordingly.

9 159 square metres being resumed from Swan Location 3211 (Public Plan Swan 1 : 10 000 2.2).

And whereas His Excellency the Governor has declared that the said lands have been set apart, taken, or resumed for the purpose of the said roads, and that plans of the said lands might be inspected at the Department of Lands and Surveys, Perth, it is hereby notified that the lands described above are roads within the meaning of the Local Government Act 1960-1981 subject to the provisions of the said Act.

Dated this 26th day of August 1981.

By Order of His Excellency,

D. J. WORDSWORTH,  
Minister for Lands.

Forests Department,  
Como, 25 August 1981.

HIS Excellency the Governor in Council has approved the following:—

Permanent Appointments

- Mason, Alison as a Clerical Officer FC2, Forests Department, as from 9 March 1981.  
Burgess, Jennifer Fay, Clerical Assistant FCI, Forests Department, as from 26 March 1981.  
Riley, Ian Edward, as a Technical Assistant, LF3, Forests Department, as from 4 June 1981.  
Whitford, Kimberley Richard, as a Technical Assistant LF3, Forests Department, as from 8 June 1981.  
Stoneman, Geoffrey Louis, as a Technical Assistant LF3, Forests Department, as from 11 May 1981.  
Sumner, Neil Robert, as a Technical Assistant LF3, Forests Department, as from 6 April 1981.  
Di Filippo, Giovanna, as a Technical Assistant LF4, Forests Department, as from 1 April 1981.  
Winters, Derek Kenneth, as a Technical Assistant LF2, Forests Department, as from 4 June 1981.

B. J. BEGGS,  
Conservator of Forests.

---

BUSH FIRES ACT 1954-1977.

(Section 38.)

Fire Weather Officers.

Bush Fires Board,  
Perth, 1 September 1981.

IT is hereby notified that the Serpentine-Jarrahdale Shire Council has appointed Mr. D. C. Daw as Fire Weather Officer for its municipal district.

The appointments of N. J. Turner and I. G. Elliott are hereby cancelled.

J. A. W. ROBLEY,  
Superintendent.

---

BUSH FIRES ACT 1954-1979.

Shire of Boyup Brook.

Firebreak Order 1981-1982.

Notice to Owners and Occupiers of Land.

PURSUANT to section 33 of the Bush Fires Act, all owners and occupiers of land within the Shire of Boyup Brook are hereby required on or before 30 November 1981, to establish firebreaks clear of all flammable materials and thereafter maintain such firebreaks clear of all flammable materials until 15 April 1982, in the following positions on land owned or occupied by them:—

Rural Lands—

- (a) A firebreak not less than 2.5 metres wide must be constructed within 100 metres of the boundary of each property, i.e. cleared or part cleared land, where the boundary is adjacent to or adjoins a constructed or used surveyed/gazetted road. Any person wishing to vary this requirement will require the approval of the Brigade Fire Control Officer, Council to be informed by the landholder before 1 October 1981, of the alternate positioning agreed to, the notification must contain the signature of the Fire Control Officer and all variations must be applied for annually.
- (b) Firebreaks are to be installed within 100 metres of the crop perimeter, by using either of the following three methods, when crops are to be harvested for grain:—
  - (1) A 3 metre firebreak inside the crop paddock.
  - (2) A 2 metre firebreak plus a 2 metre mown strip inside the crop paddock.
  - (3) A 2 metre firebreak in the adjoining paddock.

(3) A 2 metre firebreak in the adjoining paddock.

Persons not intending to harvest crops must notify the Council Office in writing, by 30 November 1981.

- (c) A firebreak 3 metres wide shall be cleared not less than 20 metres and not more than 100 metres from the perimeter of all buildings, haystacks, homesteads and fuel storage areas by 30 November 1981, and the area between the firebreaks and the building or haystack cleared of all flammable material by 15 December 1981.

Private Pine Plantations—Any pines planted for commercial purposes constitutes a pine plantation and you are hereby required to clear of all flammable materials, firebreaks not less than 50 metres wide around the perimeter of each plantation, and any plantation exceeding 50 hectares will also require a subdivisional firebreak of 50 metres in width for each 50 hectares.

Townsites—On or before 15 December 1981, all town lots under 4 000 square metres in area and all fuel depots within the Shire are required to be cleared of all debris or flammable material. A break of not less than one metre is to be cleared around the boundaries of all occupied and unoccupied lots. Lots of 4 000 square metres and over are to have minimum 2.5 metre firebreak installed around all external boundaries.

General—Provided that if, for any reason, it is impracticable to complete the clearing of firebreaks by the dates required by this notice, application must be made in writing to the Boyup Brook Shire Council not later than 30 November 1981 for permission to complete breaks by a later date. Owners or occupiers with land adjacent to Crown or Forest land may place their firebreaks in that land, with the permission of the appropriate Department, provided that the Council is notified accordingly by 30 November 1981.

Penalty not less than forty dollars nor more than four hundred dollars, in addition to which the Council may have the work carried out and recover the cost of such work from the owner and/or occupier.

Dated this 21st day of August, 1981.

By Order of the Council.

A. J. R. DOUST,  
Shire Clerk.

---

BUSH FIRES ACT 1954-1979.

Shire of Moora.

Notice to Owners and Occupiers of Land within the Shire of Moora.  
Firebreaks.

1. Pursuant to the powers contained in section 33 of the above Act, you are hereby required, on or before 31 October 1981 to plough, scarify, cultivate or otherwise clear, and thereafter maintain free of all inflammable material until 9 April 1982 in the following positions and of the following dimensions on the land owned or occupied by you.

Rural Land.

2. Firebreaks not less than two metres in width inside and along the whole of the external boundaries of the properties owned or occupied by you: But where this is not practicable the firebreaks must be provided as near as possible to, and within, such boundaries.

Farm Buildings and Unattended Electric Motors and Haystacks.

3. Firebreaks at least three metres in width completely surrounding and not more than twenty metres from the perimeter of any building, group of buildings, or haystacks. All inflammable material must be removed from an area two metres in width immediately surrounding the building. All inflammable material must be removed from an area three metres in width immediately surrounding an unattended electric motor site.

Townsites.

4. On or before 31 October 1981 all town lots within the townsites of Moora, Miling, Watheroo and Bindi Bindi are required as follows:

- (a) Where the area of land is one half of one acre or less, remove all inflammable material from the whole of the land.
- (b) Where the area of land exceeds one half of one acre, clear of all inflammable material firebreaks at least two metres wide immediately inside all internal boundaries of land, and also immediately surrounding all buildings and/or haystacks situated on the land, and maintain free of such material until 9 April 1982.

#### Fuel Pumps (Fuel Depots).

5. On or before 31 October 1981 all grass and similar material is to be cleared from areas where drum ramps are located and where drums, full or empty are stored, and such areas are to be maintained cleared of grass and similar inflammable material until 9 April 1982.

The penalty for failing to comply with this notice is a fine of not less than \$40.00 nor more than \$200.00 and a person in default is also liable, whether prosecuted or not, to pay the cost of performing the work in this notice, if it is not carried out by the Owner or Occupier by the date required by this notice.

#### Townsite Incinerators.

6. Residents of townsites throughout the Shire are reminded that incinerators for the burning of waste material should be of an approved type and be in good condition. Open drums etc. are not acceptable.

Dated this 12th day of August, 1981.

By Order of the Council,  
J. N. WARNE,  
Shire Clerk.

#### BUSH FIRES ACT 1954-1979.

##### Shire of Tammin.

Notice to all Owners and/or Occupiers of Land in the Shire of Tammin.

PURSUANT to the powers contained in section 33 of the above Act, you are hereby required on or before 31 October 1981, and thereafter up to and including 22 March 1982, to have a firebreak, cleared of all inflammable materials as set out hereunder:—

- (1) 2.5 metres immediately inside all external boundaries of the land; and
- (2) 2.5 metres wide immediately surrounding any part of the land which is in excess of 10 ha and which is being used for growing crops; and
- (3) 2.5 metres wide in such other positions as is necessary to divide land which is in excess of 100 ha and which is being used for growing crops, into areas not exceeding 100 ha each completely surrounded by a firebreak; and
- (4) Over the whole area of all lots within the townsite of Tammin.

If it is considered to be impracticable for any reason to clear firebreaks as required by this notice, you may apply to this Council or its duly authorised officer not later than 15 October 1981, for permission to provide firebreaks in alternative positions on the land. If permission is not granted by the Council or its duly authorised officer, you shall comply with the requirements of this notice.

The penalty for failing to comply with this notice is a fine of not less than \$10.00 or more than \$200.00 and a person in default is also liable, whether prosecuted or not, to pay the cost of performing the work directed in this notice if it is not carried out by the owner or occupier by the date required by this notice.

If the requirements of this notice are carried out by burning, such burning must be in accordance with the relevant provisions of the Bush Fires Act 1954-1979.

By Order of the Council,  
R. G. TONKIN,  
Shire Clerk.

#### BUSH FIRES ACT 1954-1977.

##### (Section 33.)

##### Shire of Coorow.

Notice to Owners and Occupiers of Land within the Shire of Coorow.

PURSUANT to the powers contained in section 33 of the above Act, you are hereby required on or before 31 October 1981 to plough, scarify, cultivate or otherwise clear and thereafter maintain free of all inflammable material until 15 April 1982 firebreaks of not less than two (2) metres in width in the following positions on the land owned or occupied by you.

- (1) Inside and along the whole of the external boundaries of the property or properties owned or occupied by you.
- (2) Where buildings or haystacks are situated on the property, additional firebreaks not less than 3.3 metres in width must be provided within 101 metres of the perimeter of such buildings or haystacks, in such manner as to completely encircle the buildings or haystacks.
- (3) Townsites: All townsite lots must be cleared and maintained free of all accumulations or inflammable materials.
- (4) Where land is in the Warradarge Bush Fire Brigade area, the firebreaks are to be 18.3 metres (60 ft.) wide around scrub areas that are to be burnt.

If for any reason it is considered impracticable to provide firebreaks in the position required by this notice, the approval of the Shire Clerk must be obtained to construct such firebreaks in an alternative position. Approval to any such variation will only be granted where the Bush Fire Control Officer for the area has first signified his approval to the variation.

Penalty for non-compliance: Minimum \$10.00, Maximum \$200.00.

P. J. BENNETT,  
Shire Clerk.

#### BUSH FIRES ACT 1954-1979.

##### Firebreak Order.

##### Shire of Nungarin.

PURSUANT to the powers contained in section 33 of the Bush Fires Act 1954-1979 notice is hereby given to all owners and/or occupiers of land within the Shire of Nungarin that you must prepare firebreaks complying with the following schedule on or before 30 September 1981 for grassland, and 1 November 1981, for cropland and maintain such firebreaks in a condition unable to carry a fire until 1 February 1982.

##### Schedule.

##### Rural Lands.

Breaks of not less than three metres in width immediately inside all external boundaries of the land.

Firebreaks may be ploughed, scarified or otherwise cleared of all debris of an inflammable nature and must be maintained free of such material.

##### Townsites.

All town lots within the Shire of Nungarin shall be cleared of all debris of an inflammable nature and maintained free of such material.

##### Fuel Ramps and Depots.

All grass and similar inflammable materials to be cleared from areas where drum ramps are located and where drums, full or empty, are stored and such areas maintained clear of grass and similar inflammable materials.

By Order of the Council,  
R. BRADBROOK,  
Shire Clerk.



## BUSH FIRES ACT 1954-1979.

(Section 33.)

Shire of Cunderdin.

## Firebreak Requirements 1981-1982.

Notice to all Owners and/or Occupiers of Land within the Shire of Cunderdin.

PURSUANT to the powers contained in section 33 of the above Act, you are hereby required on or before 1 November 1981, and thereafter up to and including 31 March 1982, to have firebreaks clear of all inflammable material at least 2.4 metres wide inside and along the external boundary of all land owned or occupied by you.

If it is considered to be impracticable for any reason to have firebreaks clear of all inflammable material as required by this notice, you may apply to the Council or its duly authorised officer, not later than 22 October 1981 for permission to provide firebreaks in alternative positions or to take alternative action to abate fire hazards on the land. If permission is not granted by the Council or its duly authorised officer, you shall comply with the requirements of this notice.

The penalty for failing to comply with this order is a fine of not less than \$10.00 nor more than \$200.00 and a person in default is also liable, whether prosecuted or not, to pay the cost of performing the work directed in this order if it is not carried out by the owner or occupier by the date required by this notice.

By Order of the Council.

N. J. ALCOCK,  
Shire Clerk.

## BUSH FIRES ACT 1954-1979.

Shire of Dardanup.

Firebreak Notice.

Notice to all Owners and/or Occupiers of Land in the Shire of Dardanup.

PURSUANT to the powers contained in section 33 of the Bush Fires Act 1954-1979 you are hereby required on or before the appropriate dates mentioned below and thereafter, up to and including 15 April 1982 on all land owned or occupied by you within the Shire of Dardanup to have firebreaks clear of all inflammable matter, and in accordance with the following requirements:—

## Requirements in Respect of Rural Land.

On all land owned or occupied by you which is not within a townsite or an industrial area, you must on or before 15 November 1981 have clear of all inflammable matter and all bush as defined in the Bush Fires Act, firebreaks at least 2 metres wide:—

- (a) immediately inside and along all external boundaries of the land where the land abuts formed public roads, and
- (b) within 20 metres of the perimeter of all buildings or hay stacks or groups thereof in such a manner so as to completely surround the buildings and hay stacks, and
- (c) immediately alongside all railways bounding or intersecting the land, and
- (d) in such additional or alternative positions as instructed in writing from any person authorised by the Shire of Dardanup.

## Requirements in Respect of Industrial Land.

On all land owned or occupied by you within an industrial area, you must on or before 15 November 1981 have clear of all inflammable matter and all bush as defined in the Bush Fires Act, save standing live trees, firebreaks according to the following requirements:—

- (a) where the area of land is 2 023 square metres or less and the land is not used for agriculture or grazing purposes, all inflammable matter and all bush as defined in the Bush Fires Act shall be removed from the whole of the land, or
- (b) where the area of the land is in excess of 2 023 square metres, or is used for agriculture or grazing purposes, firebreaks at least 2

metres wide shall be cleared immediately inside all the external boundaries of the land and also immediately surrounding all buildings situated on the land.

## Requirements in Respect of Urban Land.

On all land owned or occupied by you within a townsite you must on or before 15 December 1981 have clear of all inflammable matter and all bush as defined in the Bush Fires Act, save standing live trees, firebreaks according to the following requirements:—

- (a) where the area of the land is 2 023 square metres or less and the land is not used for agriculture or grazing purposes, all inflammable matter and all bush as defined in the Bush Fires Act, save standing live trees, shall be removed from the whole of the land, or
- (b) where the land is used for agriculture or grazing purposes or is more than 2 023 square metres in area, firebreaks at least 2 metres wide shall be cleared of all inflammable matter and all bush as defined in the Bush Fires Act, save standing live trees, immediately inside all the external boundaries of the land and also immediately surrounding all buildings situated on the land.

## Requirements in Respect of Fuel Storage on Rural and Urban Land.

On all land owned or occupied by you upon which there is situated any drum or drums which are normally used for the storage of automotive fuel or any ramp or other structure used for the purpose of storing such drums you must on or before 15 November 1981 have clear of all inflammable matter and all bush as defined in the Bush Fires Act, firebreaks at least 6 metres wide immediately surrounding all such drums, ramps or structures.

## Application to Vary Above Requirements.

If it is considered for any reason to be impracticable to clear firebreaks as required by this Notice, you must apply to the Council for permission to provide firebreaks in an alternative position or by an alternative date, or to take alternative action to abate fire hazards on the land. If permission is not granted by the Council, or its duly authorised Officer, you must comply with the requirements of this Notice.

## Burning.

If the requirements of this Notice are to be complied with by burning, such burning must be in accordance with the relevant provisions of the Bush Fires Act.

By Order of the Council,

C. J. SPRAGG,  
Shire Clerk.

## BUSH FIRES ACT 1954-1979.

(Section 33.)

Shire of Murray-Pinjarra.

Firebreak Order.

## Burning on Sundays/Public Holidays.

(a) Gazetted Townsites: Sunday burning is permitted on Sundays during the restricted burning period subject to compliance with the undermentioned conditions—

- (i) Area of land being .405 ha (1 acre) or less.
- (ii) Weather forecast favourable to burning.
- (iii) Requirements of section 18 of Bush Fires Act to be complied with during restricted burning period.

(b) All Other Lands—Rural and Small Holdings: Sunday burning is not permitted inclusive of townsite Lots in excess of .405 ha (1 acre).

(c) Public Holidays—Bush Fires Act 1954-1979—“Bushfire Regulations”: In accordance with the provisions of Regulation 15 C (2) of the Bushfires Regulations, burning is prohibited during the prohibited and restricted periods in Zones 6 and 8 on the following declared Public Holidays:—

Christmas Day, Boxing Day, New Year's Day, Australia Day, Labour Day, Anzac Day and applicable to Easter Friday, Saturday, Sunday, Monday and Tuesday should Easter fall within the restricted burning period for respective zones as declared in this notice.

Notice to Owners and/or Occupiers of Land.

PURSUANT to the powers contained in section 33 of the above Act, you are hereby required on or before 30 November 1981, and thereafter up to and including 15 March 1982, to have a firebreak, clear of all inflammable material at least 1.8 m (6 ft.) wide (or such other width as is specified hereunder) in the positions as set out hereunder.

1. Rural Land—(All land other than in a Townsite):

1.1 Immediately inside all boundaries of all land owned or occupied by you. No breaks are permitted to be constructed on a road reserve outside a property boundary, unless by burning referred under "Road Reserves".

1.2 Within 100 m (5 chains) of the perimeter of all buildings and/or haystacks situated on the land.

Notation: The area within the perimeter firebreak shall be cleared of all inflammable material, and maintained in such condition until the end of the restricted burning season in 1982.

2. Townsites:

2.1 Immediately inside and along all boundaries of all land of .405 ha (1 acre) or more.

2.2 On land having an area of less than .405 ha (1 acre) you shall have the whole of the land clear of all inflammable material.

2.3 N.B.—Islands in River Systems:

Owners and/or occupiers of Island Locations are required on or before 30 November 1981 and thereafter up to and including 15 March 1982 to have a firebreak clear of all inflammable material at least 1.8 m (6 ft) wide immediately inside all boundaries of land.

2.3 (b) Canal System Locations:

The requirements of section 2.2 (Townsites) will not be enforced by Council subject to owners and/or occupiers complying with the undermentioned conditions:—

(i) Land to be mowed or slashed to a level of 20 mm of growth and inflammable material raked to one specific area on location, removed or burnt.

(ii) Section 18 of the Bush Fires Act to be complied with during restricted burning period.

Notation: Council are concerned that to remove all inflammable material by cultivation or burning could create an erosion problem.

3. Fuel and/or Gas Depots:

3.1 In respect of land owned or occupied by you on which is situated any container normally used to contain liquid or gas fuel, you shall in addition to the requirements of paragraphs 2.1 and 2 above—

(a) have cleared of all inflammable material land within 20 m (1 chain) of the liquid or gas fuel container whether it contains liquid or gas fuel or not;

(b) the land on which any ramp or supports are constructed, clear of all inflammable material.

Notation: To be kept clear of inflammable material up and until 15 March 1982 in any one period.

4. Burning of Garden Refuse and Rubbish (section 25).

4.1 Garden refuse and rubbish may be burnt at any time, day or night, in a properly constructed incinerator designed to prevent the escape of sparks or burning material provided it is situated not less than 2 metres from any building or fence and the area of 2 metres surrounding the incinerator is clear of all inflammable material. Garden refuse and rubbish burnt on the ground may be burnt only between the hours of 6 o'clock in the evening and 11

o'clock of the same day and must be completely extinguished not later than midnight of that day. An area of 5 metres must be cleared all around the site of the fire and a person must remain in attendance at the site during the whole time the fire is burning. The user must extinguish the fire by the application of water or earth before he leaves it. Penalty: Fine of \$400.

Absentee Owners of Subdivisional Lots.

Contractors are available in the subdivisional areas to undertake this work if required. Arrangements should be made with contractor direct at an early date, to ensure the breaks are completed by required date.

It is the owner's responsibility to ensure that the firebreaks comply with this order. The Shire will not arrange for this work to be done. If for any reason it is considered impracticable to comply with the provisions of this order, you may make a written application for a variation to the Shire Clerk which must reach him not less than two weeks prior to the date by which the firebreak is required to be established.

No such application will be considered unless it bears the signature of the Fire Control Officer of the area, signifying his agreement to the Variation. If the application is not approved by the Shire Clerk, you shall comply with the requirements of this notice. The penalty for failing to comply with this notice is a fine of not less than \$10 or more than \$200 and the person in default is also liable, whether prosecuted or not, to pay the cost of performing the work directed in this notice if it is not carried out by the owner or occupier by the date required by this notice.

By Order of the Council,

B. M. BAKER,

Shire Clerk.

Note: The following are Townsites within the Shire: Pinjarra, Dwellingup, Coolup, North Dandalup, Yunderup, Furnissdale, Ravenswood (which includes Murray Bend).

TOWN PLANNING AND DEVELOPMENT ACT  
1928 (AS AMENDED).

Notice That a Town Planning Scheme Amendment has been Prepared and is Available for Inspection.

City of Canning Town Planning Scheme No. 16—  
Amendment No. 248.

T.P.B. 853/2/16/18, Pt. 248.

NOTICE is hereby given that the Council of the City of Canning in pursuance of its powers under the Town Planning and Development Act 1928 (as amended) has prepared a Town Planning Scheme amendment for the purpose of amending the Scheme Text by adding to the Schedule of Special Zones, Serial No. 34, being Part 2, Canning Location 298, Lynwood Arms Hotel, Lynwood, with additional purpose of up to 60 m<sup>2</sup> as a TAB Agency.

All plans and documents setting out and explaining the amendment have been deposited at Council Offices, 1317 Albany Highway, Cannington and will be open for inspection without charge during the hours of 9.00 a.m. to 4.00 p.m. on all days of the week except Saturdays, Sundays and Public Holidays until and including 2 October 1981.

The plans and documents have also been deposited at the office of the Town Planning Department, Perth and will similarly be open for inspection for the same period between the hours of 10 a.m. and 4 p.m.

Any person who desires to make a submission on the amendment should make the submission in writing in the form prescribed by the regulations and lodge it with The Town Clerk, Canning City Council, P.O. Box 42, Cannington, W.A. 6107, on or before 2 October 1981.

N. I. DAWKINS,

Town Clerk.

TOWN PLANNING AND DEVELOPMENT ACT  
1928 (AS AMENDED).

Notice That a Town Planning Scheme Amendment has been Prepared and is Available for Inspection.

City of Fremantle Town Planning Scheme No. 2—  
Amendment No. 109.

T.P.B. 853/2/5/4, Pt. 109.

NOTICE is hereby given that the Council of the City of Fremantle in pursuance of its powers under the Town Planning and Development Act, 1928 (as amended) has prepared a Town Planning Scheme amendment for the purpose of amending the Scheme Text by replacing the site coverage and parking provisions applicable to Professional Chambers in Table 2, Site Requirements.

All plans and documents setting out and explaining the amendment have been deposited at Council Offices, corner William and Newman Street, Fremantle and will be open for inspection without charge during the hours of 8.30 a.m. to 5.00 p.m. on all days of the week except Saturdays, Sundays and Public Holidays until and including 4 December 1981.

The plans and documents have also been deposited at the office of the Town Planning Department, Perth and will similarly be open for inspection for the same period between the hours of 10 a.m. and 4 p.m.

Any person who desires to make a submission on the amendment should make the submission in writing in the form prescribed by the regulations and lodge it with The Town Clerk, Fremantle City Council, P.O. Box 807, Fremantle, W.A. 6160, on or before 4 December 1981.

S. W. PARKS,  
Town Clerk.

TOWN PLANNING AND DEVELOPMENT  
ACT 1928 (AS AMENDED).

Advertisement of Approved Town Planning  
Scheme Amendment.

City of Stirling District Planning Scheme—  
Amendment Nos. 158 and 160.

T.P.B. 853/2/20, Pts. 158 and 160.

IT is hereby notified for public information, in accordance with section 7 of the Town Planning and Development Act 1928 (as amended) that the Minister for Urban Development and Town Planning approved the City of Stirling Town Planning Scheme Amendment on 28 August 1981, for the purpose of:—

Amendment No. 158—

1. Rezoning Lot 23, Location 1113, Wanneroo Road, Balga, from Single Residential to Restricted Zone—Radiology Clinic.
2. Altering Part 1 of the First Schedule to the Scheme by the addition thereto of the following:

Balga	Wanneroo Road—Portion of Location 1113 and being Lot 23 on Plan 8708 and being the land comprised in Certificate of Title Volume 61, Folio 148A	Radiology Clinic
-------	---	------------------

3. Including a notation for "Restricted Zone—Radiology Clinic" on the Scheme Map Reference Sheet.

Amendment No. 160—Amending the Scheme Text by altering the Zoning Table by inserting the symbol "AA" in column 15 and Use Class 21.

G. J. BURKETT,  
Mayor.

M. G. SARGANT,  
Town Clerk.

TOWN PLANNING AND DEVELOPMENT  
ACT 1928 (AS AMENDED).

Advertisement of Approved Town Planning  
Scheme Amendment.

City of South Perth Town Planning Scheme  
No. 2—Amendment Nos. 46 and 50.

T.P.B. 853/2/11/2, Pts. 46 and 50.

IT is hereby notified for public information, in accordance with section 7 of the Town Planning and Development Act 1928 (as amended) that the Minister for Urban Development and Town Planning approved the City of South Perth Town Planning Scheme Amendment on 28 August 1981, for the purpose of:—

Amendment No. 46—Rezoning portion of Lot 1, corner of Manning Terrace and Hurlingham Road, South Perth, from Special Service Station Zone to Commercial E Zone, as depicted on the amending plan adopted by Council on 22 July 1981 and approved by the Minister for Urban Development and Town Planning.

Amendment No. 50—Amending the Scheme Text as follows:

1. Inserting in Table No. 12 after the words "Labouchere Road" in the column headed "Road" the words:  
"(except Lot P.431)".
2. Inserting in Table No. 12 before the item "Manning Road—from Canning Highway to Ley Street" in the column headed "Road" the following new item and by inserting in the respective columns alongside that item the following words and figures:—

"Labouchere Road—Lot P.431. All Reserved Land 4 metres".

J. G. BURNETT,  
Mayor.

P. A. BENNETTS,  
Town Clerk.

TOWN PLANNING AND DEVELOPMENT  
ACT 1928 (AS AMENDED).

Advertisement of Approved Town Planning  
Scheme Amendment.

Town of Armadale Town Planning Scheme  
No. 1—Amendment No. 186.

T.P.B. 853/2/22/1, Pt. 186.

IT is hereby notified for public information, in accordance with section 7 of the Town Planning and Development Act 1928 (as amended) that the Minister for Urban Development and Town Planning approved the Town of Armadale Town Planning Scheme Amendment on 28 August 1981, for the purpose of rezoning Lot 500, corner Gilwell Avenue and Page Road, Kelmescott, from Single Residential 2A to Commercial.

I. K. BLACKBURN,  
Mayor.

A. E. RASMUSSEN,  
Town Clerk.

TOWN PLANNING AND DEVELOPMENT  
ACT 1928 (AS AMENDED).

Notice that a Town Planning Scheme Amendment has been Prepared and is Available for Inspection.

Town of Mosman Park Town Planning  
Scheme—Amendment No. 24.

T.P.B. 853/2/18/2, Pt. 24.

NOTICE is hereby given that the Mosman Park Town Council in pursuance of its powers under the Town Planning and Development Act 1928 (as amended) has prepared a Town Planning Scheme amendment for the purpose of amending the Scheme Text by adding new Clauses 5.14 and 5.15 relating to relocation and construction of additional unit for Duplex Development.

All plans and documents setting out and explaining the amendment have been deposited at Council Offices, Memorial Park, Bay View Terrace, Mosman Park and will be open for inspection without charge during the hours of 8.30 a.m. to 5.00 p.m. on all days of the week except Saturdays, Sundays and Public Holidays until and including 16 October 1981.

The plans and documents have also been deposited at the office of the Town Planning Department, Perth and will similarly be open for inspection for the same period between the hours of 10 a.m. and 4 p.m.

Any person who desires to make a submission on the amendment should make the submission in writing in the form prescribed by the regulations and lodge it with the Town Clerk, Mosman Park Town Council, P.O. Box 3, Mosman Park, W.A. 6012, on or before 16 October 1981.

D. A. WALKER,  
Town Clerk.

TOWN PLANNING AND DEVELOPMENT  
ACT 1928 (AS AMENDED).

Notice that a Town Planning Scheme Amendment has been Prepared and is Available for Inspection.

Shire of Augusta-Margaret River Town Planning  
Scheme No. 3—Amendment No. 9.

T.P.B. 853/6/3/1, Pt. 9.

NOTICE is hereby given that the Augusta-Margaret River Shire Council in pursuance of its powers under the Town Planning and Development Act 1928 (as amended) has prepared a Town Planning Scheme amendment for the purpose of rezoning Lot 18, Allnutt Terrace, Augusta, from Residential to Group Residential.

All plans and documents setting out and explaining the amendment have been deposited at Council Offices, Town View Terrace, Margaret River and will be open for inspection without charge during the hours of 9.00 a.m. to 5.00 p.m. on all days of the week except Saturdays, Sundays and Public Holidays until and including 6 October 1981.

The plans and documents have also been deposited at the office of the Town Planning Department, Perth and will similarly be open for inspection for the same period between the hours of 10 a.m. and 4 p.m.

Any person who desires to make a submission on the amendment should make the submission in writing in the form prescribed by the regulations and lodge it with the Shire Clerk, Augusta-Margaret River Shire Council, P.O. Box 61, Margaret River, W.A. 6285, on or before 6 October 1981.

K. S. PRESTON,  
Shire Clerk.

TOWN PLANNING AND DEVELOPMENT ACT  
1928 (AS AMENDED).

Advertisement of Approved Town Planning Scheme  
Amendment.

Shire of Esperance Town Planning Scheme No. 16—  
Amendment No. 52.

T.P.B. 853/11/6/11, Pt. 52.

IT is hereby notified for public information, in accordance with section 7 of the Town Planning and Development Act 1928 (as amended) that the Minister for Urban Development and Town Planning approved the Shire of Esperance Town Planning Scheme Amendment on 28 August 1981 for the purpose of:—

- (a) deleting from the Schedule of Special Use Zones, Clause 3.6 in the Scheme Text, the penultimate entry:—

Street; Particulars of Land; Permitted Use.

Cnr. Pink Lake Road and Milner Street; Lot 110 of Location 50; Funeral Parlour.

- (b) amending the Scheme Maps by rezoning Lot 110 in Location 50 from Special Use to Shopping and Central Business.

M. J. ANDRE,  
President.

E. L. CHOWN,  
Shire Clerk.

TOWN PLANNING AND DEVELOPMENT ACT  
1928 (AS AMENDED).

Notice that a Planning Scheme has been Prepared and is Available for Inspection.

Shire of Kalamunda Town Planning Scheme No. 11.—  
Lesmurdie Guided Development Scheme.

T.P.B. 853/2/24/15.

NOTICE is hereby given that the Kalamunda Shire Council in pursuance of its powers under the Town Planning and Development Act 1928 (as amended), has prepared a Planning Scheme with reference to an area situate wholly within the Shire of Kalamunda and enclosed within the inner edge of a broken black border on a plan now produced to the Council and marked and certified by the Shire Clerk under his hand dated 27 November 1980 as "Scheme Area Map" for the purpose of:—

- (a) To plan, facilitate and encourage the progressive subdivision and development of the land within the Scheme Area for residential and other purposes;
- (b) To co-ordinate and control development in the Scheme Area;
- (c) To plan and make provision for suitable roads and ways within the Scheme Area;
- (d) To make provision for and ensure the proper drainage of the roads and all other parts of the Scheme Area which require drainage;
- (e) To make provision for the creation of drainage reserves and easements within the Scheme Area;
- (f) To make provision for the reticulated supply of water and all works and matters incidental thereto within the Scheme Area;
- (g) To make provision for land to be used for Public Open Space, recreation, and Scheme purposes and for the development thereof within the Scheme Area;
- (h) To establish standards for the development of land within the Scheme Area;
- (i) To make provision within the Scheme Area for such of those matters set out in the First Schedule of the Act as are necessary or incidental to the good and effective planning, subdivision and development of a residential development scheme;
- (j) To improve and secure the amenity, health and convenience of the Scheme Area.

All plans and documents setting out and explaining the Planning Scheme have been deposited at Council Offices, 2 Railway Road, Kalamunda and will be open for inspection without charge during the hours of 9.00 a.m. to 4.30 p.m. on all days of the week except Saturdays, Sundays and Public Holidays, until and including 3 November 1981.

The maps and other documents have also been deposited at the office of the Town Planning Department, Perth, and will similarly be open for inspection for the same period between the hours of 10 a.m. and 4 p.m.

Any person who desires to make a submission on the Planning Scheme should make the submission in writing in the form prescribed by the regulations and lodge it with The Shire Clerk, Kalamunda Shire Council, 2 Railway Road, Kalamunda, W.A. 6076, on or before 3 November 1981.

E. H. KELLY,  
Shire Clerk.

TOWN PLANNING AND DEVELOPMENT ACT  
1928 (AS AMENDED).

Notice That a Town Planning Scheme Amendment has been Prepared and is Available for Inspection.

Shire of Mandurah Town Planning Scheme No. 1—  
Amendment No. 110.

T.P.B. 853/6/13/1, Pt. 110.

NOTICE is hereby given that the Mandurah Shire Council in pursuance of its powers under the Town Planning and Development Act 1928 (as amended) has prepared a Town Planning Scheme amendment for the purpose of rezoning Lot 155 and part of Lot 156 of Cockburn Sound Location 16, Fremantle Road, from Rural and Hotel and Licensed Motel to Residential C and adding a new Sub-Clause to Section 1 of the Special Schedule in the Scheme Text to allow additional use of Holiday Village and associated development for the above area.

All plans and documents setting out and explaining the amendment have been deposited at Council Offices, Mandurah Terrace, Mandurah and will be open for inspection without charge during the hours of 9.00 a.m. to 4.00 p.m. on all days of the week except Saturdays, Sundays and Public Holidays until and including 4 December 1981.

The plans and documents have also been deposited at the office of the Town Planning Department, Perth and will similarly be open for inspection for the same period between the hours of 10 a.m. and 4 p.m.

Any person who desires to make a submission on the amendment should make the submission in writing in the form prescribed by the regulations and lodge it with The Shire Clerk, Mandurah Shire Council, P.O. Box 210, Mandurah, W.A. 6210, on or before 4 December 1981.

K. W. DONOHOE,  
Shire Clerk.

TOWN PLANNING AND DEVELOPMENT ACT  
1928 (AS AMENDED).

Notice That a Town Planning Scheme Amendment has been Prepared and is Available for Inspection.

Shire of Mundaring Town Planning Scheme No. 1—  
Amendment No. 135.

T.P.B. 853/2/27/1, Pt. 135.

NOTICE is hereby given that the Mundaring Shire Council in pursuance of its powers under the Town Planning and Development Act 1928 (as amended) has prepared a Town Planning Scheme amendment for the purpose of rezoning Lot 5, Prosperity Road, Stoneville, from Rural to Special Rural Zone—Rural Residential and including relative particulars in Schedule No. 1 of the Scheme Text.

All plans and documents setting out and explaining the amendment have been deposited at Council Offices, Mundaring and will be open for inspection without charge during the hours of 9.00 a.m. to 4.00 p.m. on all days of the week except Saturdays, Sundays and Public Holidays until and including 3 November 1981.

The plans and documents have also been deposited at the office of the Town Planning Department, Perth and will similarly be open for inspection for the same period between the hours of 10 a.m. and 4 p.m.

Any person who desires to make a submission on the amendment should make the submission in writing in the form prescribed by the regulations and lodge it with The Shire Clerk, Mundaring Shire Council, P.O. Box 20, Mundaring, W.A. 6073 on or before 3 November 1981.

M. N. WILLIAMS,  
Shire Clerk.

TOWN PLANNING AND DEVELOPMENT ACT  
1928 (AS AMENDED).

Notice That a Town Planning Scheme Amendment has been Prepared and is Available for Inspection.

Shire of Swan Town Planning Scheme No. 1—  
Amendment No. 104.

T.P.B. 853/2/21/1, Pt. 104.

NOTICE is hereby given that the Swan Shire Council in pursuance of its powers under the Town Planning and Development Act 1928 (as amended) has prepared a Town Planning Scheme amendment for the purpose of rezoning Lot 1 of Swan Location 16, No. 31 Victoria Street, Midland, from General Residential 5 to Service Industry.

All plans and documents setting out and explaining the amendment have been deposited at Council Offices, Great Northern Highway, Middle Swan and will be open for inspection without charge during the hours of 9.00 a.m. to 4.30 p.m. on all days of the week except Saturdays, Sundays and Public Holidays until and including 16 October 1981.

The plans and documents have also been deposited at the office of the Town Planning Department, Perth and will similarly be open for inspection for the same period between the hours of 10 a.m. and 4 p.m.

Any person who desires to make a submission on the amendment should make the submission in writing in the form prescribed by the regulations and lodge it with The Shire Clerk, Swan Shire Council, P.O. Box 196, Midland, W.A. 6056, on or before 16 October 1981.

R. F. COFFEY,  
Shire Clerk.

TOWN PLANNING AND DEVELOPMENT  
ACT 1928 (AS AMENDED).

Advertisement of Approved Town Planning  
Scheme Amendment.

Shire of Wanneroo Town Planning Scheme  
No. 1—Amendment No. 190.

T.P.B. 853/2/30/1, Pt. 190.

IT is hereby notified for public information, in accordance with section 7 of the Town Planning and Development Act 1928 (as amended) that the Minister for Urban Development and Town Planning approved the Shire of Wanneroo Town Planning Scheme Amendment on 28 August 1981 for the purpose of rezoning the portion of State Forest No. 69, bounded by Hodges Drive, Mitchell Freeway, Shenton Avenue and Connolly Drive, Connolly, from Reserve for State Forest to Residential Development, as depicted on the amending plan adopted by Council on 17 December 1980 and approved by the Minister for Urban Development and Town Planning.

M. O'BRIEN,  
President.

N. S. BENNETTS,  
Shire Clerk.

TOWN PLANNING AND DEVELOPMENT ACT  
1928 (AS AMENDED).

Shire of Morawa.

Interim Development Order No. 2.

T.P.B. 26/3/12/1.

NOTICE is hereby given that in accordance with the provisions of sub-section (2) of section 7B of the Town Planning and Development Act 1928 (as amended), and by direction of the Minister for Urban Development and Town Planning a summary as set out hereunder of the Morawa Shire Council Interim Development Order No. 2 made pursuant to the provisions of Section 7B of that Act is published for general information.

The Minister for Urban Development and Town Planning has made copies of this Order available for inspection by any person free of charge at the offices of the Town Planning Board, Oakleigh Building, 22 St George's Terrace, Perth, and at the offices of the Morawa Shire Council during normal office hours.

## SUMMARY.

1. The Shire of Morawa Interim Development Order No. 2 contains provisions *inter alia*:—
  - (a) That the Order applies to that part of the Shire of Morawa specified in the Order.
  - (b) That, subject as therein stated, the Morawa Shire Council is the authority responsible for its administration.
  - (c) That the carrying out of certain development on land within the scope of the Order without approval as stated therein is prohibited.
  - (d) Relating to the application for, and grant of approval for, development other than development permitted by the Order.
  - (e) Relating to development by a public authority.
  - (f) Relating to certain development permitted by this Order.
  - (g) Relating to the continuance of the lawful use of land and buildings.
  - (h) Relating to appeals against refusal of approval for development or against conditions subject to which approval to carry out development is granted.
2. The Order has effect from and after the publication of this Summary in the *Government Gazette*.

K. L. HILL,  
Shire Clerk.

## METROPOLITAN REGION TOWN PLANNING SCHEME ACT 1959.

## Metropolitan Region Scheme.

## Notice of Resolution.

NOTICE is hereby given that at its meeting on 26 August 1981 the Metropolitan Region Planning Authority (in this notice called "the Authority"), acting under clause 32 of the Metropolitan Region Scheme, by resolution—

- (a) revoked the resolution made by it on 21 September 1977 and published in the *Government Gazette* on 30 September 1977;
- (b) defined the areas in respect of which the proposals contained in the Metropolitan Region Scheme which relate to those areas are to be reviewed by the Authority as the areas specified in the Schedule to this notice;
- (c) required that every application for commercial development on land in the areas specified in the Schedule to this notice should be referred to the Authority for determination;
- (d) required that a local authority forward every application for commercial development referred to in paragraph (c) of this notice to the Authority for determination;
- (e) declared that for the purposes of that resolution—

"application for commercial development" means application relating to a building or extensions to a building proposed to be used for commercial purposes, which building, or building as extended by those extensions, as the case requires—

- (a) exceeds; or
- (b) would, if that application were approved, cause the shopping centre of which it forms part to exceed, 5 000 square metres in gross leasable area or forms part of a shopping centre which already exceeds 5 000 square metres in gross leasable area;

"building proposed to be used for commercial purposes" excludes building or portion thereof that is proposed to be used solely for the purposes of a warehouse, office (being an office not related in any way to a shop), fuel depot, service station, petrol filling station, milk depot, marine store, timber yard or of the sale of motor vehicles or of industrial premises or of a tavern, hotel, betting shop, child minding centre or public toilet or of public rest rooms or of a public building as defined by section 173 of the Health Act 1911;

"gross leasable area"—

- (a) means area of all floors capable of being occupied by a tenant for his exclusive use, which area is measured from the centre lines of joint partitions or walls and from the outside faces of external walls or the building alignment, including shop fronts; and

(b) includes basements, mezzanines and storage areas;

"shopping centre" means—

- (a) within the district of the City of Perth—

- (i) those portions of the Reserve, as defined by By-law No. 43 made by the Council of the City of Perth under the Municipal Corporations Act 1906 and the City of Perth Endowment Lands Act 1920\*, specified in the second schedule to that By-law;

- (ii) No. 6 Zone, No. 7 Zone and No. 8 Zone as defined by the Second Schedule to By-law No. 63 made by the Council of the City of Perth under the Local Government Act 1960 and the Town Planning and Development Act 1928\*\*;

\* Published in the *Government Gazette* of 23 August 1956 at pages 2131 to 2134.

\*\* Published in the *Government Gazette* of 10 October 1961 at pages 2862 to 2871.

- (iii) No. 6 Zone, No. 7 Zone and No. 8 Zone as defined by the Second Schedule to By-law No. 64 made by the Council of the City of Perth under the Local Government Act 1960 and the Town Planning and Development Act 1928\*\*\*;
- (iv) No. 6 Zone, No. 7 Zone and No. 8 Zone as defined by the Second Schedule to By-law No. 65 made by the Council of the City of Perth under the Local Government Act 1960 and the Town Planning and Development Act 1928\*\*\*\*;
- (b) outside the district of the City of Perth, area zoned under a town planning scheme for a use, by whatever name called, which permits use for the purposes of shops;
- (f) declared that the Interpretation Act 1918 applied to that resolution as that Act applies to Acts of the Parliament of Western Australia.

Schedule.

All areas of land in the Metropolitan Region zoned under the Metropolitan Region Scheme, except for—

- (a) the areas zoned "Central City Area" on Map Sheets Nos. 7, 16 and 19 of the 1 : 25 000 consolidated copy of the Metropolitan Region Scheme;
- (b) the area defined as the total Study Area for the Armadale Sub-Regional Centre Study in the Schedule to the notice of the resolution made by the Authority on 25 October 1978, which notice was published in the *Government Gazette* of 24 November 1978 at page 4399;
- (c) the area defined in Schedule 1 to the notice of the resolution made by the Authority on 22 April 1981, which notice was published in the *Government Gazette* of 8 May 1981 at page 1429;
- (d) the area of land bounded by Read Street, Leghorn Street, Dowling Street, Hawkins Street and Council Avenue and zoned "Urban" on Map Sheet No. 27 of the 1 : 25 000 consolidated copy of the Metropolitan Region Scheme.

H. R. P. DAVID,  
Secretary,  
Metropolitan Region Planning Authority.

\*\*\* Published in the *Government Gazette* of 10 October 1961 at pages 2871 to 2880.

\*\*\*\* Published in the *Government Gazette* of 24 May 1962 at pages 1340 to 1350.

METROPOLITAN REGION TOWN PLANNING  
SCHEME ACT 1959-1980.

Metropolitan Region Scheme.

Notice.

Wungong Gorge and Environs.

File: 833/2/22/4; Amendment No. 328/33.

1. It is hereby notified for public information that the Amendment to the Metropolitan Region Scheme, as modified by the Metropolitan Region Planning Authority following the hearing of submissions, and as referred to in the First Schedule hereto, has been approved by His Excellency the Governor in accordance with the provisions of section 33 of the Metropolitan Region Town Planning Scheme Act 1959-1980.

2. The Minister for Urban Development and Town Planning has determined that copies of the maps, plans or diagrams that form part of the Amendment, as modified by the Metropolitan Region Planning Authority, and approved by His Excellency the Governor, be made available for public inspection as from 9 September 1981, during normal office hours, at the places mentioned in the Second Schedule hereto.

H. R. P. DAVID,  
Secretary,  
the Metropolitan Region  
Planning Authority.

First Schedule.

Metropolitan Region Scheme Map Sheets numbered 24, 25 and 28 are respectively amended by the Metropolitan Region Planning Authority Amendment Map Sheets numbered 24/5 m, 25/4 m and 28/1 m dated 29 June 1981.

The Amendment reserves portion of the Wungong Gorge and Environs for Parks and Recreation purposes.

Second Schedule.

Public Inspection:

1. Office of the Town Planning Department, 2nd Floor, Oakleigh Building, 22 St. George's Terrace, Perth.
2. Office of the municipality of the City of Perth, Council House, 27 St. George's Terrace, Perth.
3. Office of the municipality of the City of Fremantle, Civic and Administration Centre, William Street, Fremantle.
4. Office of the municipality of the Town of Armadale, Jull Street, Armadale.
5. Office of the municipality of the Shire of Serpentine-Jarrahdale, Patterson Street, Mündijong.
6. The State Reference Library, 40 James Street, Perth (between the hours of 9.00 a.m. to 9.45 p.m. Mondays to Saturdays inclusive of each week and between 2.00 p.m. and 5.00 p.m. on Sunday).

## PUBLIC WORKS DEPARTMENT.

Tenders, closing at West Perth at 2.30 p.m. on the dates mentioned hereunder, are invited for the following projects.

Tenders are to be addressed to the Minister (either for Works or for Water Resources, as indicated on the tender document).

C/- Contract Office,  
Public Works Department,  
Dumas House,  
2 Havelock Street,  
West Perth. Western Australia 6005

and are to be endorsed as being a tender for the relevant project.

The highest, lowest, or any tender will not necessarily be accepted.

Contract No.	Project	Closing Date	Tender Documents now available at
22728 ....	The Queen Elizabeth II Medical Centre—Sir Charles Gairdner Hospital Engineering Dept. Workshops New Metal Trades Workshop "W" Block	15/9/81	P.W.D., West Perth
22737 ....	Derby—Department for Community Welfare, School Hostel—Upgrade, new ablutions, repairs and renovations	29/9/81	P.W.D., West Perth P.W.D., A.D., Derby P.W.D., A.D., Sth. Hedland P.W.D., West Perth
22738 ....	Boyup Brook Water Supply 200m <sup>3</sup> Steel Water Storage Tank on 15m Stand	8/9/81	P.W.D., West Perth
22741 ....	North Albany High School—Terrazzo Work—Nominated Sub Contract	8/9/81	P.W.D., A.D., Albany P.W.D., West Perth
22742 ....	North Albany High School—Gymnasium Flooring—Nominated Sub Contract	8/9/81	P.W.D., West Perth P.W.D., A.D., Albany
22743 ....	Karratha Senior High School Additions—Ceilings Sub Contract	8/9/81	P.W.D., West Perth P.W.D., A.D., Karratha P.W.D., A.D., Sth. Hedland P.W.D., West Perth
22744 ....	Metropolitan Prison Complex—Canning Vale—New H.V. Power Supply	15/9/81	P.W.D., West Perth
ADQ2817	Geraldton—Swan Drive, Bluff Point—Department for Community Welfare Group Home—Supply and Installation of Carpet	8/9/81	P.W.D., A.D. Furniture Office 2nd Floor, Rm 223, 2 Havelock Street, West Perth P.W.D., A.D., District Supervisor, Marine Terrace, Geraldton, W.A. 6530
22745 ....	Education Department Head Office—East Perth—Partitions ....	15/9/81	P.W.D. West Perth
22746 ....	Queen Elizabeth II Medical Centre Metal Trades Workshop—"W" Block—Electrical Installation Nominated Sub Contract	15/9/81	P.W.D., West Perth
22747 ....	North Albany High School Cabinetwork Nominated Sub Contract	22/9/81	P.W.D., West Perth P.W.D., A.D., Albany P.W.D., A.D., Bunbury
22748 ....	Forrestfield High School Suspended Ceilings Nominated Sub Contract	15/9/81	P.W.D., West Perth
22750*	Lesmurdie High School Library—Stage 2B ....	22/9/81	P.W.D., West Perth
22751 ....	Pemberton Water Supply 1 000 m <sup>3</sup> Reinforced Concrete Tank	22/9/81	P.W.D., West Perth
22752 ....	The Queen Elizabeth II Medical Centre Waste Processing Plant Building Electrical	15/9/81	P.W.D., West Perth
22753 ....	Esperance Primary School Library Resource Centre and Upgrade—Electrical Installation	15/9/81	P.W.D., West Perth Clerk of Courts, Esperance P.W.D., A.D., Kalgoorlie P.W.D., A.D., Albany P.W.D., A.D., Bunbury
ADQ2835	Hampton Senior High School Library Resource Centre and Additions Supply and Lay Carpet	8/9/81	P.W.D., A.D., Furniture Office, 2nd Floor, Rm 223 2 Havelock Street, West Perth 6005
ADQ2842	Pinjarra Senior High School Community Recreation Centre Supply and Lay Carpet	8/9/81	P.W.D., A.D., Furniture Office 2nd Floor, Rm 223, 2 Havelock Street, West Perth 6005
22754 ....	Lesmurdie High School Library Stage 2B Metal Strip Ceilings NSC	22/9/81	P.W.D., West Perth
22755 ....	Transportable Classrooms 1981-82 ....	22/9/81	P.W.D., West Perth
22756 ....	Esperance Sewerage Pumping Station No. 2—Civil Works ....	29/9/81	P.W.D., West Perth P.W.D., W.S., Kalgoorlie P.W.D., W.S., Esperance
22757 ....	Esperance Sewerage Reticulation Area No. 2 Gravity Sewers	29/9/81	P.W.D., West Perth P.W.D., W.S., Kalgoorlie P.W.D., W.S., Esperance
22758 ....	Wickham District High School—Stage 1—Mechanical Services	29/9/81	P.W.D., West Perth P.W.D., A.D., Sth Hedland P.W.D., A.D., Geraldton
22759 ....	Wickham District High School Stage 1—1981 Electrical Installation Nominated Sub Contract	29/9/81	P.W.D., West Perth P.W.D., A.D., Karratha P.W.D., A.D., Sth Hedland P.W.D., A.D., Geraldton
22760 ....	Lesmurdie High School Library Stage 2B—Electrical Installation Nominated Sub Contract	22/9/81	P.W.D., West Perth



PUBLIC WORKS DEPARTMENT—*continued.*

Contract No.	Project	Closing Date	Tender Documents now available at
ADQ2848	Country High School Hostel Authority—St. Andrew's Hostel—Katanning Supply and Installation of Carpet in Supervisors Quarters	22/9/81	P.W.D., A.D., Furniture Office, 2nd Floor, Room 223, 2 Havelock Street, West Perth 6005 P.W.D., A.D., District Supervisor "Champion House" 63 Serpentine Road, Albany 6330 P.W.D., A.D., District Supervisor 11 Stirling Street, Bunbury 6230

\* Deposit on documents \$75.

## ACCEPTANCE OF TENDERS

Contract No.	Project	Contractor	Amount
			\$
22706 ....	The Queen Elizabeth II Medical Centre—V.H.F. Radio Paging	Philips Electronic Systems ....	102 093
22734 ....	Thornlie Technical College Stage II—Supply and Instal Concrete Well	Trident Plumbing Pty. Ltd.	27 431
22685 ....	Onslow Water Supply 100 m <sup>3</sup> Steel Water Storage Tank on 15 m Stand	Atkinson Steel Products ....	68 120
22714 ....	Public Trust Office, 565 Hay Street, Perth—Floor, Window and General Cleaning	Powerclean Services ....	20 485 p.a.
22625 ....	Geraldton Regional Water Supply Geraldton—Tarcoola High Level Area 2 250 m <sup>3</sup> Reinforced Concrete Elevated Tank	General Construction (W.A.) Pty. Ltd. and Advantengineering-Civil Engineers	849 749

K. T. CADEE,  
Under Secretary for Works.

RIGHTS IN WATER AND IRRIGATION ACT  
1914-1978.

NOTICE is hereby given that the rate books for all land in the Collie River, Waroona, Harvey Sub-Areas 1, 2, 3 and 4, and Ord River Irrigation Districts, liable to be rated under the abovementioned Act, for the Financial Year ending on the 31st day of August 1982, have been made up and are open to inspection by any ratepayer at all reasonable times.

Dated this 1st day of September, 1981.

K. T. CADEE,  
Under Secretary for Works.

Provided that the rated area of any holding does not exceed the area allocated for irrigation watering and that the minimum rate to be made and levied on each separately assessed holding, the rate on which at \$64.05 per hectare would not exceed \$64.05, shall be \$64.05.

2. A rate of \$8.93 per hectare shall be made and levied on all irrigable land within the Ord Irrigation District liable to be rated, and the rated area of any holding not to exceed the area allocated for irrigation watering.

Dated this 1st day of September, 1981.

K. T. CADEE,  
Under Secretary for Works.

RIGHTS IN WATER AND IRRIGATION ACT  
1914-1978.

Notice of Order to Make and Levy Irrigation Rates for the year ending 31 August 1982.

NOTICE is hereby given under subsection (1) and (2) of section 40 of the Rights in Water and Irrigation Act 1914-1978 and section 79 of the Water Boards Act 1904-1979 that the Minister for Works and Water Resources, being the Minister charged with the administration of that Act, acting under that Act, has ordered that the Irrigation Rates to be made and levied in respect of the financial year ending on 31 August 1982, shall be as set out in the schedule hereunder:—

## 1. For

- All irrigable land within the Collie River Irrigation District, the Waroona Irrigation District, and the Harvey Irrigation District Sub-Areas Numbers 2 and 3 shall be levied a rate of \$64.05 assessed in the proportion of one hectares in three of each holding liable to be rated.
- Every hectare of irrigable land in each holding within the Harvey Irrigation District Sub-Areas Numbers 1 and 4, liable to be rated shall be levied a rate of \$64.05.

(3)—14271

## LAND DRAINAGE ACT 1925-1978.

NOTICE is hereby given that the rate books for all land in each of the areas liable to be rated under the abovementioned Act for the ten months from 1 September 1981 to 30 June 1982 have been made up and are open for inspection by any rate payer at all reasonable times.

Dated this 1st day of September, 1981.

K. T. CADEE,  
Under Secretary for Works.

## LAND DRAINAGE ACT 1925-1978.

Notice of Order to Make and Levy Drainage Rates for Ten Months from 1 September 1981 to 30 June 1982.

NOTICE is hereby given under section 92 of the Land Drainage Act 1925-1978 that the Minister for Works and Water Resources, being the Minister charged with the Administration of that Act, acting under that Act has ordered that the Drainage Rates to be made and levied within each Drainage area in respect of

the ten months from 1 September 1981 to 30 June 1982, for holdings or parts of holdings classified under the Act for Drainage purposes shall be as set out in the schedule hereunder:

1. Busselton, Collie River, Harvey, Pinjarra, Serpentine/Mundijong, Waroona and West Harvey Drainage Districts.

- 1.1. All land—30c per hectare.
- 1.2. Land with cut off facility in addition to 1.1 above—75c per hectare.
- 1.3. Land with outlet facility in addition to 1.1 and 1.2 above if applicable:
  - (a) 28 hectares or part thereof nearest to the outlet—\$2.25 per hectare.
  - (b) 20 hectares or part thereof next to the 28 hectares nearest to the outlet—\$1.50 per hectare.
  - (c) 12 hectares or part thereof next to the 48 hectares nearest to the outlet—75c per hectare.
  - (d) in excess of 60 hectares nearest to the outlet—30c per hectare.

Subject to a minimum rate of \$9 for each parcel of land.

2. Capel/Boyanup Drainage District.

- 2.1 Category "A" 3.5c in \$ on Unimproved Value.
- 2.2. Category "B" 1.5c in \$ on Unimproved Value.
- 2.3. Category "C" 0.875c in \$ on Unimproved Value.

Subject to a minimum rate of \$9 for each parcel of land.

3. Mayalup Drainage District. All land 0.75c in \$ on Unimproved Value, subject to a minimum rate of \$9 for each parcel of land.

4. Stirling Drainage District.

- 4.1. Grading "A" 4.5c in \$ on Unimproved Value.
- 4.2. Grading "B" 3.0c in \$ on Unimproved Value.
- 4.3. Grading "C" 2.0c in \$ on Unimproved Value.
- 4.4. Grading "D" 1.5c in \$ on Unimproved Value.

Subject to a minimum rate of \$9 for each parcel of land.

5. Wilson/Torbay Drainage District.

- 5.1. Category "A" 6.666 7c in \$ on Unimproved Value.
- 5.2. Category "B" 2.416 7c in \$ on Unimproved Value.
- 5.3. Category "C" 1.25c in \$ on Unimproved Value.

Subject to a minimum rate of \$9 for each parcel of land.

6. Wungong Drainage District.

- 6.1. All land—17.5c per hectare.
- 6.2. Land with cut off facility in addition to 6.1 above—17.5c per hectare.
- 6.3. Land with outlet facility in addition to 6.1 and 6.2 above if applicable:
  - (a) 4.0 hectares or part thereof nearest the outlet—\$1.691 7 per hectare.
  - (b) 4.0 hectares or part thereof next to the 4.0 hectares nearest the outlet—\$1.45 per hectare.
  - (c) 4.0 hectares or part thereof next to the 8.0 hectares nearest the outlet—\$1.291 7 per hectare.
  - (d) 4.0 hectares or part thereof next to the 12.0 hectares nearest the outlet—\$1.125 per hectare.
  - (e) 4.0 hectares or part thereof next to the 16.0 hectares nearest the outlet—95c per hectare.

- (f) 4.0 hectares or part thereof next to the 20.0 hectares nearest the outlet—77.5c per hectare.
- (g) 4.0 hectares or part thereof next to the 24.0 hectares nearest the outlet—57.5c per hectare.
- (h) 8.0 hectares or part thereof next to the 28.0 hectares nearest the outlet—35c per hectare.
- (i) in excess of the 36 hectares nearest the outlet—11.666 7c per hectare.

Subject to a minimum rate of \$9 for each parcel of land.

7. Parkfield Drainage District. All land 0.75c in \$ on Unimproved Value, subject to a minimum rate of \$9 for each parcel of land.

8. Preston River Drainage District. All land 0.125c in \$ on Unimproved Value, subject to a minimum rate of \$6.666 7 for each parcel of land.

Dated the 1st day of September 1981.

K. T. CADEE,  
Under Secretary for Works.

---

#### WESTERN AUSTRALIAN MARINE ACT 1948-1980.

Restricted Speed Areas—Private Pleasure Craft.

Harbour and Light Department,  
Fremantle, 31 August 1981.

ACTING pursuant to the powers conferred by section 16B of the Western Australian Marine Act the Harbour and Light Department, by this notice revokes portion of sub-paragraph 3 (b) (ii) of the notice published in the *Government Gazette* of 3 August 1979, as follows:—

This revocation will only apply to those waters described in sub-paragraph 3 (b) (ii) of the above notice lying south of a line drawn due west from the Overseas Telecommunications Cable Station at Leighton and will only apply to members of the Offshore Powerboat Club of W.A. competing in organised racing between 9.00 a.m. and 12.00 p.m. on Sunday, 7 September 1981.

C. J. GORDON,  
Manager.

---

#### NAVIGABLE WATERS REGULATIONS.

Water Ski Areas.

Harbour and Light Department,  
Fremantle, 31 August 1981.

ACTING pursuant to the powers conferred by Regulation 48A of the Navigable Waters Regulations the Harbour and Light Department, by this notice, defines and sets aside the following area of navigable waters for the purpose of water skiing only:—

A course commencing from the water ski area at Mill Point, South Perth and proceeding in a generally South West direction to University Buoy thence in a generally South East direction to Knot Spit and Inner Dolphin thence South to Outer Dolphin then back to the starting point via Concrete Spit.

Providing however that this course may only be used by members of the West Australian Water Ski Association in the Swan River Classic between the hours of 9.30 a.m. and 1.30 p.m. on Sunday 6 September 1981.

C. J. GORDON,  
Manager.

WESTERN AUSTRALIAN MARINE ACT 1948-1980.  
PREVENTION OF COLLISIONS AT SEA AMENDMENT  
REGULATIONS 1981.

MADE by His Excellency the Governor in Executive Council.

Citation. 1. These regulations may be cited as the Prevention of Collisions at Sea Amendment Regulations 1981.

Rule 38 amended. 2. Rule 38 of the Prevention of Collisions at Sea Regulations 1977\* is amended in subrules (a) and (b) by deleting "15th July, 1981" and substituting the following—

" 30 November 1981 " .

By His Excellency's Command,  
J. E. A. PRITCHARD,  
Acting Clerk of the Council.

\* Published in the *Government Gazette* of 6 July 1977 at pp. 2083-2104.

SHIPPING AND PILOTAGE ACT 1967-1976.

PORTS AND HARBOURS AMENDMENT  
REGULATIONS (No. 6) 1981.

MADE by His Excellency the Governor in Executive Council.

Citation. 1. These regulations may be cited as the Ports and Harbours Amendment Regulations (No. 6) 1981.

Third Schedule amended. 2. The Third Schedule to the Ports and Harbours Regulations\*, as amended, is amended in Part I by deleting item 2 and substituting the following item—

" 2. Movements within port—

- (a) the charge for the pilotage of a vessel being removed from a place in a port to another place in that port not being a removal to or to near the pilot boarding ground shall be \$120.00;
- (b) the charge for the pilotage of a vessel from a berth within a port to a place within that port at or near the pilot boarding ground or *vice versa* shall be half the combined inward and outward pilotage charge applicable to the vessel;
- (c) where a pilot boat and crew are used in connection with a removal referred to in paragraph (a) of this item a further charge, being launch hire, of \$60.00 per hour or part thereof shall apply together with an additional charge of \$20.00 per hour or part thereof when the pilot boat and crew are used during overtime hours. "

By His Excellency's Command,  
J. E. A. PRITCHARD,  
Acting Clerk of the Council.

\* Published in the *Government Gazette* on 3 February 1966 at p. 277.

WESTERN AUSTRALIAN MARINE ACT 1948-1980.

LIMITED COAST-TRADE VESSELS AMENDMENT REGULATIONS  
(No. 2) 1981.

MADE by His Excellency the Governor in Executive Council.

Citation and principal regulations. 1. (1) These regulations may be cited as the Limited Coast-trade Vessels Amendment Regulations (No. 2) 1981.  
(2) In these regulations the Limited Coast-trade Vessels Regulations\*, as amended, are referred to as the principal regulations.

\* Reprinted in the *Government Gazette* on 17 December 1975 at pp. 4549-4561.

Regulation 40 amended. 2. Regulation 40 of the principal regulations is amended in subregulation (1) by deleting paragraph (a) and substituting the following paragraph—

“ (a) in the case of an application for a Master's Certificate involving an examination—

(i) in navigation, seamanship and signalling, of \$60.00; or

(ii) in signalling only, of \$10.00 for each attempt at that examination;

and ” .

Regulation 44 amended. 3. Regulation 44 of the principal regulations is amended by repealing subregulation (1) and substituting the following subregulation—

“ (1) A candidate for a Master's Certificate—

(a) shall be examined in navigation, seamanship and signalling; and

(b) if he passes the examination referred to in paragraph (a) of this subregulation in all the subjects referred to in that paragraph except for signalling, may again offer himself for examination in signalling and be examined therein on any occasion or occasions within 6 months after that passing. ” .

By His Excellency's Command,

J. E. A. PRITCHARD,  
Acting Clerk of the Council.

WESTERN AUSTRALIAN MARINE ACT 1948-1980.

WESTERN AUSTRALIAN MARINE ACT (EXAMINATIONS)  
AMENDMENT REGULATIONS (No. 2) 1981.

MADE by His Excellency the Governor in Executive Council.

Citation and principal regulations. 1. (1) These regulations may be cited as the Western Australian Marine Act (Examinations) Amendment Regulations (No. 2) 1981.

(2) In these regulations the Western Australian Marine Act (Examinations) Regulations\*, as amended, are referred to as the principal regulations.

Regulation 7A inserted. 2. The principal regulations are amended by inserting, after regulation 7 and before the heading “Master of a Coast Trade Ship Over 300 Tons Gross Register”, the following regulation—

Candidate may retake examination in signalling. “ 7A. (1) A candidate who—

(a) offers himself for examination, and is examined, in the subjects referred to in regulations 4, 5, 6 and 7 of these regulations; and

(b) passes the examination referred to in subparagraph (a) of this subregulation in all the subjects referred to in that paragraph except for signalling,

may again offer himself for examination in signalling and be examined therein on any occasion or occasions within 6 months after the passing referred to in paragraph (b) of this subregulation.

(2) In this regulation—

“signalling” means the International Code of Signals and Morse Code. ” .

Regulation 11A inserted. 3. The principal regulations are amended by inserting, after regulation 11 and before the heading “Mate of a Coast Trade Ship Under 300 Tons Gross Register”, the following regulation—

Candidate to take examinations at same time, but may retake examination in signalling. “ 11A. (1) A candidate who offers himself for examination in the subjects referred to in regulations 9, 10 and 11 of these regulations shall be examined in all those subjects on one and the same occasion.

(2) A candidate who—

(a) is examined under subregulation (1) of this regulation; and

(b) passes the examination referred to in paragraph (a) of this subregulation in all the subjects referred to in regulations 9, 10 and 11 of these regulations except for signalling,

may again offer himself for examination in signalling and be examined therein on any occasion or occasions within 6 months after the passing referred to in paragraph (b) of this subregulation.

(3) In subregulation (2) of this regulation—

“signalling” means the International Code of Signals and Morse Code. ” .

Regulation 15A inserted. 4. The principal regulations are amended by inserting, after regulation 15 and before the heading "Master of a Coast Trade Ship under 300 Tons Gross Register", the following regulation—

Candidate to take examinations at same time, but may retake examination in signalling.

" 15A. (1) A candidate who offers himself for examination in the subjects referred to in regulations 13, 14 and 15 of these regulations shall be examined in all those subjects on one and the same occasion.

(2) A candidate who—

(a) is examined under subregulation (1) of this regulation; and

(b) passes the examination referred to in paragraph (a) of this subregulation in all the subjects referred to in regulations 13, 14 and 15 of these regulations except for signalling,

may again offer himself for examination in signalling and be examined therein on any occasion or occasions within 6 months after the passing referred to in paragraph (b) of this subregulation.

(3) In subregulation (2) of this regulation—

"signalling" means the International Code of Signals and Morse Code. "

Regulation 18A inserted.

5. The principal regulations are amended by inserting, after regulation 18 and before the heading "Coxswain of a Harbour and River Ship", the following regulation—

Candidate to take examinations at same time, but may retake examination in signalling.

" 18A. (1) A candidate who offers himself for examination in the subjects referred to in regulation 18 of these regulations shall be examined in all those subjects on one and the same occasion.

(2) A candidate who—

(a) is examined under subregulation (1) of this regulation; and

(b) passes the examination referred to in paragraph (a) of this subregulation in all the subjects referred to in regulation 18 of these regulations except for signalling,

may again offer himself for examination in signalling and be examined therein on any occasion or occasions within 6 months after the passing referred to in paragraph (b) of this subregulation.

(3) In subregulation (2) of this regulation—

"signalling" means the International Code of Signals and Morse Code. "

Regulation 33 amended.

6. Regulation 33 of the principal regulations is amended by inserting—

(a) after the regulation designation "33.", the following subregulation designation—

" (1) " ; and

(b) after the existing regulation, the following subregulation—

" (2) Notwithstanding anything in subregulation (1) of this regulation, a candidate offering himself for examination only in signalling as defined by regulation 7A (2), 11A (3), 15A (3) or 18A (3), as the case requires, of these regulations shall pay to the Department a fee of \$10.00 in respect of each such offer. "

By His Excellency's Command,

J. E. A. PRITCHARD,  
Acting Clerk of the Council.

\* Reprinted in the *Government Gazette* on 3 April 1974 at p. 1163.

#### WESTERN AUSTRALIAN MARINE ACT 1948-1980.

#### NAVIGABLE WATERS AMENDMENT REGULATIONS (No. 5) 1981.

MADE by His Excellency the Governor in Executive Council.

Citation. 1. These regulations may be cited as the Navigable Waters Amendment Regulations (No. 5) 1981.

Principal regulations. 2. In these regulations, the Navigable Waters Regulations\*, as amended, are referred to as the principal regulations.

Reg. 52CA inserted. 3. After regulation 52C of the principal regulations, the following regulation is inserted—

" 52CA. (1) A provision of regulations 52A, 52B and 52C of these regulations does not apply to a vessel while it is taking part in any race or regatta for which permission has been granted by the Department under regulation 51C if—

(a) a written exemption has been granted by the department under subregulation (2) of this regulation from that provision, for that vessel or description of vessel during that race or regatta; and

(b) the owner and the person in charge of the vessel comply with the terms and conditions of the exemption imposed on them respectively by the department.

(2) The department may, upon written application, grant an exemption described in subregulation (1) (a) of this regulation if it is satisfied that the safety of competitors in the race or regatta will not be endangered by the grant of the exemption; and may impose conditions on the owners and persons in charge of vessels taking part therein and on the person or persons by whom the race or regatta is organised.

(3) Without limiting the other grounds on which the department may refuse to grant an exemption under subregulation (2) of this regulation, it shall not grant an exemption unless it is satisfied that—

(a) the race or regatta is to commence after sunrise and be completed before sunset; and

(b) a sufficient number of suitable rescue craft will be available throughout the duration of the event. ”

Reg. 53  
amended.

4. Regulation 53 of the principal regulations is amended—

(a) by inserting after the regulation designation “53.” the subregulation designation “(1)”; and

(b) by inserting the following subregulations—

“ (2) Every person who by act or omission fails to comply with any condition imposed on him under regulation 52CA (2) commits an offence and is liable on conviction to a fine not exceeding two hundred dollars.

(3) It is a defence to a complaint of an offence against subregulation (2) of this regulation for an owner or a person in charge of a vessel who is charged with the offence to show that he did not know, and could not reasonably be expected to have known, of the condition imposed under regulation 52CA (2). ”

By His Excellency's Command,

J. E. A. PRITCHARD,  
Acting Clerk of the Council.

\* Reprinted in *Government Gazette* of 23 July 1979 pp. 2047-2069; amended in *Government Gazettes* of 9 February, 16 March and 7 September 1979, 20 June and 28 November 1980, and 26 June 1981.

L. & S. 1777/76

*Public Works Act 1902; Local Government Act 1960*

#### NOTICE OF INTENTION TO TAKE OR RESUME LAND

THE Minister for Works hereby gives notice, in accordance with the provisions of Section 17 (2) of the Public Works Act 1902, that it is intended to compulsorily acquire on behalf of the City of Bunbury under Section 17 (1) of that Act, the several pieces or parcels of land described in the schedule hereto for Road Purposes, and that the said pieces or parcels of land are marked off on Lands and Surveys Diagram 84501, copies of which may be inspected at the Office of the Minister for Lands, Perth, and at the office of the City of Bunbury.

#### SCHEDULE

No.	Owner or Reputed Owner	Occupier or Reputed Occupier	Description	Area (approx.)
1.	Antonio Achille Castrilli	A. A. Castrilli	Portion of Leschenault Location 26 and being part of Lot 190 on Office of Titles Plan 318 and being portion of the land contained in Certificate of Title Volume 41 Folio 57	707 m <sup>2</sup>
2.	Roderick Stanley Cross	R. S. Cross	Portion of Leschenault Location 26 and being part of Lot 191 on Office of Titles Plan 318 and being portion of the land contained in Certificate of Title Volume 40 Folio 55	937 m <sup>2</sup>

Dated this 4th day of September, 1981.

B. L. O'HALLORAN,  
Under Secretary for Lands.

L. &amp; S. 776/76

*Public Works Act 1902; Local Government Act 1960*

## NOTICE OF INTENTION TO TAKE OR RESUME LAND

THE Minister for Works hereby gives notice, in accordance with the provisions of Section 17 (2) of the Public Works Act 1902, that it is intended to compulsorily acquire on behalf of the City of Stirling under Section 17 (1) of that Act, the several pieces or parcels of land described in the schedule hereto for Road Purposes, and that the said pieces or parcels of land are marked off on Lands and Surveys Diagram 84210 copies of which may be inspected at the Office of the Minister for Lands, Perth, and at the office of the City of Stirling.

## SCHEDULE

No.	Owner or Reputed Owner	Occupier or Reputed Occupier	Description	Area (approx.)
1.	Graham Robert Gaunt	G. R. Gaunt	Portion of Herdsman Lake Lot 148 and being portion of Lot 1 on Office of Titles Diagram 14458 and being portion of the land comprised in Certificate of Title Volume 1115 Folio 770	141 m <sup>2</sup>
2.	Roy Albert Gaunt and Shirley Joy Gaunt	R. A. Gaunt and Gaunt	S. J. Portion of Herdsman Lake Lot 148 and being part of Lot 2 on Office of Titles Diagram 15498 and being portion of the land comprised in Certificate of Title Volume 1133 Folio 89	20 m <sup>2</sup>
3.	Wladyslaw Wawizyniak and Barbara Wawizyniak	W. Wawizyniak and Wawizyniak	B. Portion of Herdsman Lake Lot 148 and being part of Lot 3 on Office of Titles Diagram 15498 and being portion of the land comprised in Certificate of Title Volume 1133 Folio 90	7 m <sup>2</sup>
4.	Kenneth Albert Law	K. A. Law	Portion of Herdsman Lake Lot 148 and being part of the land comprised in Certificate of Title Volume 28 Folio 346A	31 m <sup>2</sup>

Dated this 4th day of September, 1981.

B. L. O'HALLORAN,  
Under Secretary for Lands.

M.R.D. 42/147-F

*Main Roads Act 1930-1977; Public Works Act 1902-1974*

## NOTICE OF INTENTION TO TAKE OR RESUME LAND

THE Minister for Works hereby gives notice, in accordance with the provisions of Section 17 (2) of the Public Works Act 1902-1974, that it is intended to take or resume under Section 17 (1) of that Act the pieces or parcels of land described in the Schedule hereto and being all in the Northampton District, for the purpose of the following public works, namely, the realignment of North West Coastal Highway (48·0-50·0 SLK Section) and that the said pieces or parcels of land are marked off on Plan M.R.D., W.A., 8025-124, which may be inspected at the Office of the Commissioner of Main Roads, Waterloo Crescent, East Perth.

## SCHEDULE

No.	Owner or Reputed Owner	Occupier or Reputed Occupier	Description	Area (approx.)
1.	Digby Lee-Steere Pty. Ltd.	Hon. Minister for Works (Purchaser <i>vide</i> Caveat C 178021)	Portion of Bowes Agricultural Area Lot 46 (Certificate of Title Volume 1533, Folio 578)	4 860 m <sup>2</sup>
2.	Digby Lee-Steere Pty. Ltd.	Hon. Minister for Works (Purchaser <i>vide</i> Caveat C 178021)	Portion of Bowes Agricultural Area Lot 47 (Certificate of Title Volume 1533, Folio 578)	2 946 m <sup>2</sup>
3.	Digby Lee-Steere Pty. Ltd.	Hon. Minister for Works (Purchaser <i>vide</i> Caveat C 178021)	Portion of Bowes Agricultural Area Lot 48 (Certificate of Title Volume 1533, Folio 578)	6 096 m <sup>2</sup>
4.	Kaburie Pty. Ltd.	Kaburie Pty. Ltd.	Portion of Bowes Agricultural Area Lot 1 (Certificate of Title Volume 1207, Folio 116)	4 861 m <sup>2</sup>
5.	Robert Henry Hasleby	R. H. Hasleby	Portion of Victoria Location 2762 (Certificate of Title Volume 432, Folio 185)	1·08 ha

Dated this 2nd day of September, 1981.

D. R. Warner,  
Secretary, Main Roads.

## WATER BOARDS ACT 1904-1969.

## Sections 41-45.

## Bunbury Water Board.

NOTICE is hereby given of the intention of the Bunbury Water Board to undertake construction of the Works hereinafter described by virtue of the powers contained under the provisions of the Water Board Act 1904-1969.

## Description of Works.

1. Construction of a Treatment Plan which includes—
  - (a) Clearing access.
  - (b) Two (2) Sedimentation Tanks and Aerators.
  - (c) Three (3) Steel Filter Shells.
  - (d) Installation of two (2) Bores.
  - (e) Purchase three (3) sets of Pumping Equipment.
  - (f) Construction of Pumping Shed Delivery Pumps, fencing and Electrical Supply.
  - (g) Rising Mains.
2. Kelly Park.  
Construction of sub station and renewal of power mains as requested by S.E.C.
3. Purchase of New Metric Water Meters.
4. Mangles Street Treatment Plant: Install one (1) steel filter shell.
5. Main Extension: In Clifton and Molloy Street from Victoria Street to Eliot Street.
6. Plant: Replacement of Tractor/Backhoe and assistant supervisors one (1) Ton Ute.
7. Depot Improvements: Construction of new office building and storage facilities.
8. Pumping Equipment: Purchase of borehole and booster pumping equipment.

## Location of Works.

1. Within a proposed reserve at junction of Reserve 34489 Lot 586 and Water Supply Reserve Lot 619.
2. Within Council Reserve 25362 Kelly Park.
3. Within Water Board area.
4. Within Water Board Reserve 31373 Mangles Street.
5. Within Clifton and Molloy Street road reserves.
6. For use within Water Board area.
7. Within Council Reserve 26119 Little Street.
8. Within Water Board Area.

## Purpose of Works.

The purpose of the proposed Loan is to improve the water supply to the City.

## Area to be Supplied with Water.

The City of Bunbury.

It is considered that the whole of the Bunbury Water Board area will benefit from the proposed works.

The annual value of the Water Board Area for 1981-1982 is \$11 933 614 and the estimated rate return for 1981-1982 is \$900 270.

Plans and specifications may be inspected at the office of the Bunbury Water Board, Stephen Street, Bunbury for one month after 11 September 1981.

Dated this 28th day of August, 1981.

P. J. USHER,  
Chairman.

## TOWN OF MOSMAN PARK.

## Municipal Fund.

## STATEMENT OF RECEIPTS AND PAYMENTS FOR THE YEAR ENDED 30 JUNE 1981.

Receipts.		\$
Rates .. .. .	618 909	
Licences .. .. .	11 444	
Government Grants and Recoups .. .. .	151 404	
M.R.D. Base Grant .. .. .	20 300	
Income from Property .. .. .	31 409	
Sanitation Charges .. .. .	3 494	
Fines and Penalties .. .. .	2 038	
Other Fees .. .. .	1 459	
Contributions to Works .. .. .	53 640	
All Other Receipts .. .. .	24 484	
Sale of Assets .. .. .	150	
Refunds .. .. .	5 972	
		<u>\$924 703</u>

## Payments.

Administration:		\$
Staff Section .. .. .	89 334	
Membership Section .. .. .	9 059	
Debt Service .. .. .	63 307	
Public Works and Services .. .. .	342 781	
Buildings—Construction and Equipment .. .. .	68 282	
Building Maintenance .. .. .	18 276	
Town Planning .. .. .	2 745	
Health Services .. .. .	6 673	
Sanitation .. .. .	102 345	
Prevention of Disease .. .. .	1 265	
Dog Control .. .. .	10 644	
Building Control .. .. .	14 528	
Plant and Equipment .. .. .	912	
Donations and Grants:		
Statutory .. .. .	22 541	
Non-statutory .. .. .	825	
Transfers to Reserve Funds .. .. .	29 000	
Parking Control .. .. .	5 120	
Library Services .. .. .	48 364	
All Other Expenditure .. .. .	7 236	
		<u>\$843 237</u>

## SUMMARY.

		\$
Credit Balance B/Fwd 1 July 1980 .. .. .	32 388	
Receipts per Statement .. .. .	924 703	
		<u>957 091</u>
Payments per Statement .. .. .	843 237	
Credit Balance—30 June 1981 .. .. .	\$113 854	

## BALANCE SHEET AS AT 30 JUNE 1981.

Assets.		\$
Current Assets .. .. .	187 431	
Non-current Assets .. .. .	104 790	
Reserve Fund Contra .. .. .	82 046	
Fixed Assets (nett) .. .. .	853 793	
Total Assets .. .. .	<u>\$1 228 060</u>	

## Liabilities.

		\$
Current Liabilities .. .. .	17 853	
Non-current Liabilities .. .. .	95 132	
Deferred Liabilities .. .. .	368 100	
Total Liabilities .. .. .	<u>\$481 085</u>	

## SUMMARY.

		\$
Total Assets .. .. .	1 228 060	
Total Liabilities .. .. .	481 085	
Municipal Accumulation Account Surplus .. .. .	<u>\$746 975</u>	

Contingent Liability: The amount of interest included in loan debentures issued payable over the life of the loans and not shown under the heading of Loan Liability is approximately \$232 546.

We hereby certify that the figures and particulars given above are correct.

D. G. JONES,  
Mayor.

D. A. WALKER,  
Town Clerk.

I have audited the books of account of the Town of Mosman Park for the year ended 30 June 1981. In my opinion the Balance Sheet and the related financial statements are prepared on a basis consistent with the Local Government Act Accounting Directions and present a true and fair view of the state of affairs of the Town of Mosman Park at 30 June 1981.

K. ROBERTSON,  
Auditor, State Audit Department.

## SHIRE OF CRANBROOK.

## STATEMENT OF RECEIPTS AND PAYMENTS FOR THE YEAR ENDED 30 JUNE 1981.

Receipts.		\$
Rates .. .. .	206 637.83	
Licences .. .. .	62 757.59	
Government Grants .. .. .	230 591.00	
Statutory Road Grants .. .. .	87 460.00	
Income from Property .. .. .	39 856.88	
Sanitation and Health .. .. .	8 669.57	
Fines and Penalties .. .. .	45.00	
Cemetery Receipts .. .. .	154.00	
Vermine Receipts .. .. .	16.40	
Other Fees .. .. .	1 089.60	
Other Revenue (Including Private Works) .. .. .	66 523.65	
Sale of Assets (Plant) .. .. .	52 696.00	
Total Receipts .. .. .	<u>\$756 497.52</u>	



Payments.		\$
Administration:		
Staff	71 341.85	
Members	7 946.73	
Debt Service	56 686.13	
Public Works and Services	332 548.15	
Building Construction, Maintenance and Equipment	38 594.32	
Library	2 323.11	
Health Services	12 669.17	
Vermin Control	Nil	
Bush Fire Control	2 991.69	
Traffic Control	2 272.94	
Cemeteries	767.58	
Public Works and Overheads Unallocated	Nil	
Plant and Tools	114 394.04	
Plant Operation Costs Unallocated	1 176.03	
Materials Overallocated	3 076.63	
Main Roads Trust Funds (Licences)	54 763.34	
Donations and Grants	1 055.00	
Other Expenditure—Private Works	29 248.82	
Other Expenditure	586.19	
Transfer to Reserve and Trust Funds	34 700.00	
<b>Total Payments</b>	<b>\$760 988.46</b>	

## SUMMARY.

	\$
Bank Balance 1/7/80 (Cr.)	9 338.37
Total Receipts as per Statement	756 497.52
<b>Less Payments as per Statement</b>	<b>765 835.89</b>
	<b>760 988.46</b>
Credit Balance 30 June 1981	\$4 847.43

## BALANCE SHEET AS AT 30 JUNE 1981.

Assets.		\$
Current Assets:		
Bank Balance	4 847.43	
Sundry Debtors	4 539.75	
Stock in Hand	23 017.50	
Non-current Assets:		
Trust Fund	3 048.69	
Reserve Funds	105 700.17	
Deferred Assets:		
S.E.C. Extensions and Deposits	1 346.70	
Reserve Fund Contra	105 700.17	
Fixed Assets	755 598.22	
<b>Total Assets</b>	<b>\$1 003 798.63</b>	
Liabilities.		
Accrued Interest on Loans		
	5 930.72	
Non-current Liabilities:		
Trust Fund	3 048.69	
Reserve Funds	105 700.17	
Deferred Liabilities: Loan Liability	259 401.30	
<b>Total Liabilities</b>	<b>\$374 080.88</b>	
SUMMARY.		
Total Assets	1 003 798.63	
Total Liabilities	374 080.88	
Municipal Accumulation Account (Surplus)	\$629 717.75	

Contingent Liability: The amount of interest included in Loan Debentures issued, payable over the life of the loans, and not shown under the heading of Loan Liability is approximately \$130 114 of which \$27 854 is repayable by local sporting organisations and \$223 is repayable by ratepayers under contract for S.E.C. Extensions.

We hereby certify that the figures and particulars in these Statements are correct.

R. W. DENNEY,  
Acting President.

B. R. GENONI,  
Shire Clerk.

I have audited the books of account of the Shire of Cranbrook for the year ended 30 June 1981. In my opinion, the balance sheet and related financial statements are prepared on a basis consistent with the Local Government Act Accounting Directions and present a true and fair view of the state of affairs of the Shire of Cranbrook as at 30 June 1981.

N. R. WOODS,  
Auditor, State Audit Department.

## SHIRE OF MORAWA.

## STATEMENT OF RECEIPTS AND PAYMENTS FOR THE YEAR ENDED 30 JUNE 1981.

Receipts.		\$
Rates	215 183.54	
Sewerage Rates	28 425.55	
Licences	487.11	
Government Grants	400 108.39	
Income from Property	60 689.57	
Sanitation	10 441.86	
Cemetery Fees	168.00	
Vermin Services	49.00	
Fines and Penalties	100.00	
All Other Revenue	42 495.99	
<b>Total Receipts</b>	<b>\$758 149.01</b>	

Expenditure.		\$
Administration:		
Staff Section	72 840.65	
Members Section	9 422.49	
Debt Service	200 552.73	
Public Works and Services	285 575.42	
Buildings: Construction and Equipment	10 055.13	
Buildings Maintenance	50 254.94	
Health Services	5 693.45	
Water Supplies	956.57	
Sanitation	26 118.75	
Vermin Services	2 565.63	
Bushfire Control	5 447.65	
Traffic Control	2 505.10	
Cemetery	1 589.36	
Plant, Machinery and Tools	8 356.00	
Materials	Cr. 1 226.84	
Donations and Grants	1 870.00	
All Other Works and Services	19 210.05	
All Other Expenditure	3 684.40	
<b>Total Expenditure</b>	<b>\$705 471.48</b>	

## Summary.

	\$
Credit Balance 1 July 1980	3 628.37
Receipts as Per Statement	758 149.01
<b>Payments as per bank Statement</b>	<b>761 777.38</b>
	<b>705 471.48</b>
Credit Balance 30 June 1981	\$56 305.90

## BALANCE SHEET AS AT 30 JUNE 1981.

Assets.		\$
Current Assets:		
Municipal Fund Bank	56 305.90	
Sundry Debtors	9 076.29	
Stocks	6 851.84	
Non-current Assets	7 360.89	
Deferred Assets	5 246.86	
Fixed Assets	1 773 843.55	
<b>Total Assets</b>	<b>\$1 858 685.33</b>	
Liabilities.		
Current Liabilities		
Non-current Liabilities	2 176.76	
Deferred Liabilities	1 313 978.67	
<b>Total Liabilities</b>	<b>\$1 338 843.36</b>	
SUMMARY.		
Total Assets	1 858 685.33	
Total Liabilities	1 338 843.36	
Municipal Accumulation Account Surplus	\$519 841.97	

We hereby certify that the particulars and figures shown are correct.

J. A. NORTH,  
President.

K. L. HILL,  
Shire Clerk.

I have audited the books of accounts of the Shire of Morawa for the year ended 30 June 1981. In my opinion the balance sheet and related financial statements are prepared on a basis consistent with the Local Government Act Accounting Directions and present a true and fair view of the state of affairs of the Shire of Morawa as at 30 June 1981.

P. SPAAPEN,  
Auditor, State Audit Department.

## SHIRE OF MURRAY.

## STATEMENT OF RECEIPTS AND PAYMENTS FOR THE YEAR ENDED 30 JUNE 1981.

Receipts.		\$
Rates	537 613.54	
Licences	10 983.86	
Government Grants	607 662.09	
Contribution to Works and Private Works	35 892.77	
Income from Property	25 488.23	
Sanitation	61 573.35	
Town Planning	1 325.00	
Cemetery	2 995.00	
Library Services	66.87	
Other Services	4 401.96	
Fines and Penalties	6 215.00	
Sale of Assets	35 806.70	
Other Receipts	138 446.31	
Refunds and Transfers (Net)	—	
<b>Total Receipts</b>	<b>\$1 468 470.68</b>	

Payments.		\$
Administration Staff	.....	118 701.20
Administration—Members	.....	11 709.90
Debt Service	.....	207 133.89
Public Works and Services	.....	—
Road Construction	.....	244 699.23
Road Maintenance	.....	221 846.51
Reserves Construction	.....	22 661.62
Reserves Maintenance	.....	68 297.08
Building Construction and Fixed Equipment	.....	150 296.11
Building Maintenance	.....	46 777.12
Equipment Purchases	.....	16 188.63
Plant Purchases	.....	120 020.61
Sanitation Service	.....	74 685.81
Health Service	.....	27 985.84
Building Service	.....	26 562.60
Town Planning Service	.....	21 007.04
Cemetery	.....	2 951.63
Library Service	.....	15 428.04
Bush Fire Control	.....	12 179.37
Other Public Services	.....	20 169.37
Pay Roll	.....	—
Public Works Overhead	.....	—
Plant Operation Cost	.....	30 000.00
Materials	.....	17 216.88
Donations and Grants	.....	160.00
Transfers to Reserve Funds	.....	75 558.44
All Other Expenditure	.....	21 734.80
Refunds and Transfers	.....	9 984.54
<b>Total Payments</b>		<b>\$1 583 956.26</b>

## SUMMARY.

		\$
Credit Bank Balance 1/7/81	.....	164 150.62
Receipts as per Statement	..... Cr.	1 468 470.68
		<u>1 632 621.30</u>
Payments as per Statement	.....	1 583 956.26
Credit Balance 30/6/81	..... Cr.	<u>\$48 665.04</u>

## BALANCE SHEET AS AT 30 JUNE 1981.

Assets.		\$
Current Assets:		
Cash at Bank	.....	48 665.04
Petty Cash	.....	250.00
Sundry Debtors	.....	144 278.62
Stock on Hand	.....	39 921.50
Non Current Assets	.....	364 857.11
Deferred Assets	.....	854 139.46
Contra Reserve Accounts	.....	145 342.81
Fixed Assets	.....	1 582 935.72
		<u>\$3 180 390.26</u>
Liabilities.		
Current Liabilities:		
Sundry Creditors	.....	618.71
Accrued Interest on Loans	.....	26 130.91
Non Current Liabilities:		
Trust Funds	.....	95 587.80
Long Service Leave Reserve	.....	18 022.80
Plant Replacement Reserve	.....	114 689.43
Housing Reserve	.....	12 360.30
Deferred Liabilities:		
Loan Liability	.....	1 457 252.69
<b>Total Liabilities</b>		<b>\$1 724 662.64</b>
		\$
Total Assets	.....	3 180 390.26
Total Liabilities	.....	1 724 662.64
Municipal Accumulations A/c.	.....	1 455 727.62

We hereby certify that the figures and particulars in accordance with statements attached are correct.

A. B. GILES,  
President.

B. M. BAKER,  
Shire Clerk.

Dated this 14th day of August, 1981.

I have examined the books of account and applied audit test checks to the financial transactions of the Shire of Murray for the financial year ended 30 June 1981. The accompanying financial statements are in my opinion properly drawn up to give a true and fair view of the state of affairs of the Shire of Murray at 30 June 1981, subject to qualifications/or observations contained in my report.

M. J. BREMAN,  
(Auditor-Audit Department)  
Auditor General's Department.

SHIRE OF TAMMIN.  
STATEMENT OF RECEIPTS AND PAYMENTS FOR YEAR ENDED 30 JUNE 1981.

Receipts.		\$
Rates	.....	116 060.21
Licences	.....	36 167.18
Government Grants and Recoups	.....	108 900.00
C.A.R. Statutory Grant	.....	45 370.00
Income from Property	.....	19 086.30
Private Works	.....	8 127.56
Health Services	.....	20 760.48
Sanitation Charges	.....	3 670.42
Cemetery Receipts	.....	57.00
Other Fees	.....	462.00
All Other Revenue	.....	3 502.60
Other Receipts	.....	11 268.32
		<u>\$373 432.07</u>

Payments.		\$
Administration:		
Staff	.....	37 349.72
Membership	.....	2 767.13
Debt Service	.....	49 079.60
Public Works and Services	.....	145 480.13
Buildings:		
Construction and Equipment	.....	1 354.99
Maintenance	.....	10 207.25
Library	.....	1 946.86
Water Supply	.....	96.06
Health Services and Sanitation	.....	26 052.53
Bush Fire Control	.....	1 277.03
Traffic Control	.....	500.65
Cemetery	.....	461.68
Plant Machinery and Tools	.....	12 421.61
Operation Costs (N.A.)	.....	1 981.07
Materials Purchased (N.A.)	.....	205.17
Payments to C.A.R. Fund	.....	32 263.95
Donations and Grants:		
Statutory	.....	600.00
Non-Statutory	.....	72.40
Transfer to Long Service Leave Reserve	.....	1 500.00
Other Works and Services	.....	5 283.52
All Other Expenditure	.....	13 858.44
		<u>\$344 759.79</u>

## SUMMARY.

		\$
Debit Balance 1/7/80	.....	15 465.87
Receipts as per Statement	.....	373 432.07
		<u>357 966.20</u>
Payments as per Statement	.....	344 759.79
Credit Balance 30/6/81	.....	<u>\$13 206.41</u>

## BALANCE SHEET AS AT 30 JUNE 1981.

Assets.		\$
Current Assets	.....	28 916.28
Stock on Hand	.....	8 345.63
Non-current Assets	.....	5 729.55
Reserve Fund Contra	.....	1 755.89
Fixed Assets	.....	483 822.01
Investment in Trading Concern	.....	21 677.14
		<u>\$550 246.50</u>
Liabilities.		
		\$
Current Liabilities	.....	15 679.01
Non-current Liabilities	.....	1 755.89
Deferred Liabilities	.....	239 961.32
		<u>\$257 396.22</u>
SUMMARY.		
		\$
Total Assets	.....	550 246.50
Total Liabilities	.....	257 396.22
Municipal Accumulation Account Surplus	.....	<u>\$292 850.28</u>

We hereby certify that the figures and particulars above are correct.

A. E. ROGERS,  
President.

R. G. TONKIN,  
Shire Clerk.

Dated this 13th day of July, 1981.

I have audited the books of account of the Shire of Tammin for the year ended 30 June 1981. In my opinion the balance sheet and the related financial statements are prepared on a basis consistent with the Local Government Act accounting directions and present a true and fair view of the state of affairs of the Shire of Tammin as at 30 June 1981.

E. B. PEGG,  
Auditor, State Audit Department.

## SHIRE OF WOODANILLING.

## Municipal Fund.

## STATEMENT OF RECEIPTS AND PAYMENTS FOR THE YEAR ENDED 30 JUNE 1981.

Receipts.		\$
Rates .. .. .	76 532	
Licences .. .. .	31 632	
Government Grants .. .. .	130 875	
Income from Property .. .. .	15 276	
Health Services .. .. .	2 600	
Other Receipts .. .. .	5 124	
Other .. .. .	51 524	
	<u>\$313 562</u>	

Payments.		\$
Administration:		
Staff Section .. .. .	33 197	
Members Section .. .. .	3 248	
Debt Service .. .. .	31 361	
Public Works and Services .. .. .	133 660	
Building Construction and Equipment .. .. .	7 492	
Buildings Maintenance .. .. .	5 707	
Health Services .. .. .	3 818	
Bushfire Control .. .. .	1 884	
Noxious Weed Control .. .. .	1 049	
Traffic Control .. .. .	1 298	
Cemeteries .. .. .	329	
Public Works Overheads Unallocated .. .. .	3 322	
Plant Machinery and Tools .. .. .	54 079	
Operation Costs Overallocated .. .. .	Cr. 690	
Material Unallocated .. .. .	677	
M.R.D. Trust Payment .. .. .	31 581	
Donations and Grants .. .. .	90	
Bank Transfers .. .. .	2 000	
All Other Expenditure .. .. .	5 358	
	<u>\$319 462</u>	

## SUMMARY.

	\$
Balance C/fwd 30 June 1980 .. .. .	13 556
Receipts 1980/81 .. .. .	313 562
	<u>327 118</u>
Payments 1980/81 .. .. .	319 462
Credit Balance 30/6/1981 .. .. .	<u>\$7 656</u>

## BALANCE SHEET AS AT 30 JUNE 1981.

	\$
Current Assets .. .. .	19 186
Non-current Assets .. .. .	7 257
Deferred Assets .. .. .	6 730
Fixed Assets .. .. .	321 912
	<u>\$355 085</u>

## Liabilities.

	\$
Current Liabilities .. .. .	5
Non-current Liability .. .. .	7 257
Deferred Liability .. .. .	121 418
	<u>\$128 680</u>

## SUMMARY.

	\$
Total Assets .. .. .	355 085
Total Liabilities .. .. .	128 680
Municipal Accumulation a/c .. .. .	<u>\$226 405</u>

We certify the figures and particulars shown in the above statements are correct.

J. FORSYTH,  
President.  
P. A. ANNING,  
Shire Clerk.

I have audited the books of account of the Shire of Woodanilling for the year ended 30 June 1981.

In my opinion the balance sheet and related financial statements are prepared on a basis consistent with the Local Government Act Accounting Directions and present a true and fair view of the State of Affairs of the Shire of Woodanilling as at 30 June 1981.

N. R. WOODS,  
Auditor, State Audit Department.

## SHIRE OF YILGARN.

## Municipal Fund.

## STATEMENT OF RECEIPTS AND PAYMENTS FOR THE YEAR ENDED 30 JUNE 1981.

Receipts.		\$
Rates .. .. .	251 282.13	
Licences .. .. .	108 273.76	
Government Grants and Recoups .. .. .	269 084.00	
Statutory Grant .. .. .	193 250.00	
Income from Property .. .. .	56 000.67	
Sanitation .. .. .	5 314.16	
Fines and Penalties .. .. .	40.73	
Cemetery .. .. .	199.75	
Other Fees .. .. .	12 271.60	
All Other Revenue .. .. .	163 984.52	
	<u>\$1 059 701.32</u>	

Expenditure.		\$
Administration:		
Staff .. .. .	79 001.37	
Members .. .. .	9 543.04	
Debt Service .. .. .	131 102.23	
Public Works and Services .. .. .	432 229.28	
Buildings:		
Construction .. .. .	15 491.50	
Maintenance .. .. .	43 352.68	
Health Services .. .. .	17 967.09	
Vermin Services .. .. .	3 315.45	
Bush Fire Control .. .. .	2 966.21	
Traffic Control .. .. .	6 533.15	
Cemetery .. .. .	1 474.33	
Public Works Overheads .. .. .	1 482.50	
Plant, Machinery and Tools .. .. .	169 714.52	
Operation Costs .. .. .	Cr. 4 651.38	
Materials .. .. .	Cr. 1 219.87	
Payment to C.A.R. Fund .. .. .	107 515.91	
Donations and Grants .. .. .	537.00	
All Other Expenditure .. .. .	33 908.48	
	<u>\$1 050 263.49</u>	

## SUMMARY.

	\$
Credit Balance .. .. .	40 546.64
Receipts as per Statement .. .. .	1 059 701.32
	<u>1 100 247.96</u>
Payments as per Schedule .. .. .	1 050 263.49
Credit Balance 30 June 1981 .. .. .	<u>\$49 984.47</u>

## BALANCE SHEET AS AT 30 JUNE 1981.

Assets.		\$
Current Assets .. .. .	69 208.55	
Non-current Assets .. .. .	73 417.53	
Reserve Fund Contra .. .. .	14 526.69	
Stocks .. .. .	1 870.02	
Deferred Assets .. .. .	75 180.57	
Fixed Assets .. .. .	1 664 022.15	
	<u>\$1 898 225.51</u>	

## Liabilities.

	\$
Current Liabilities .. .. .	1 360.48
Non-current Liabilities .. .. .	23 417.53
Deferred Liabilities .. .. .	878 130.90
	<u>\$902 908.91</u>

## SUMMARY.

	\$
Total Assets .. .. .	1 898 225.51
Total Liabilities .. .. .	902 908.91
Municipal Accumulation Account .. .. .	<u>\$995 316.00</u>

We hereby certify that the figures and particulars above are correct.

K. M. BEATON,  
President.  
R. W. MANGINI,  
Shire Clerk.

I have audited the Books of Account of the Shire of Yilgarn for the year ending 30 June 1981. In my opinion, the Balance Sheet and related Financial Statements are prepared on a basis consistent with the Local Government Act Accounting Directions and present a true and fair view of the State of Affairs of the Shire of Yilgarn as at 30 June 1981.

E. B. PEGG,  
Auditor, State Audit Department.

## LOCAL GOVERNMENT ACT 1960-1981.

Town of Claremont.

IT is hereby notified for public information that the Claremont Baptist Church Inc. of 332 Stirling Highway Claremont has consented to the publication of the following notice.

The Town of Claremont hereby declares that paragraph (c) of subsection (3) of section 532 of the Local Government Act 1960-1981 shall not apply to the land described in the schedule hereto and that all of the rates imposed with respect to the land and improvements, from time to time, shall be paid notwithstanding the fact that the land is to be used and occupied exclusively for charitable purposes relating to the provision of accommodation for Aged Persons.

D. H. TINDALE,  
Town Clerk.

The Schedule.

All that piece of land being portion of Swan location 350 and being lot 29 on plan 2180 and being the whole of the land comprised in Certificate of Title Volume 562 Folio 76.

## SHIRE OF MANDURAH.

Acting Shire Clerk.

IT is hereby notified for Public Information that Edgar William Hatton has been appointed Acting Shire Clerk from 20 August 1981 to 7 September 1981.

P. F. THOMAS (Miss),  
President.

## TOWN OF COTTESLOE.

IT is hereby notified for public information that John Murray Gray has been appointed as Ranger for the Town of Cottesloe from 28 August 1981, for the purpose of control and supervision of the by-laws of the Council including:—

- (a) Authorised Officer under the Dog Act 1976-1977.
- (b) Council By-laws on:—
  - Street Lawns and Gardens.
  - Parking Facilities.
  - Beaches, Reserves and other matters.
  - Caravans.
  - Removal and Disposal of Obstructing Animals or Vehicles.
  - Dogs.
  - Deposit of Refuse and Litter.
  - Parking of Commercial Vehicles on Street Verges.
- (c) Authorised Person under section 665b of the Local Government Act 1960-1981.
- (d) Poundkeeper and Ranger under section 450 of the Local Government Act 1960-1981.

The appointment of Donald David Salmon is hereby cancelled.

R. PEDDIE,  
Town Clerk.

26 August 1981.

## SHIRE OF ROEBOURNE.

Appointment of Acting Shire Clerk.

IT is hereby notified for Public Information that Mr. Brian George Willoughby has been appointed Acting Shire Clerk for the period 31 August 1981 to 11 September 1981, both inclusive.

R. CRANE,  
President.

## SHIRE OF EAST PILBARA.

Appointment of Litter Inspectors.

IT is hereby notified for public information that the undermentioned persons have been appointed Litter Inspectors by this Council in accordance with section 665A of the Local Government Act 1960-1981.

John Maitland Read.  
Michael Thomas Howieson.  
Leonard Allan Welch.  
Peter Crawford.  
Morris Frederick Penny.  
Gordon Collins.

J. M. READ,  
Shire Clerk.

## SHIRE OF EAST PILBARA.

Appointment of Dog Inspector.

IT is hereby notified for public information that the undermentioned person has been appointed authorised Dog Inspector by this Council under the provisions of the Dog Act 1976-1977.

CHRIS RILEY.

Appointment of Mr. John Anderson cancelled.

J. M. READ,  
Shire Clerk.

## SHIRE OF KOJONUP.

IT is hereby notified that Pascoe Durtanovich has been appointed Shire Clerk, Shire of Kojonup from 31 August 1981.

The appointment of Stanley Arthur Giese is hereby cancelled.

## CITY OF BUNBURY.

Parking Inspector.

IT is hereby notified for public information that Mr. Thomas Graeme Raine has been appointed as a Parking Inspector for the City of Bunbury as from 26 August 1981.

The appointment of Mr. Larry Hartmann as Parking Inspector was cancelled as from 28 August 1981.

W. J. CARMODY,  
Town Clerk.

## LOCAL GOVERNMENT ACT 1960-1981.

Shire of Carnarvon.

IT is hereby notified for public information that the following persons have been appointed Honorary Litter Wardens in accordance with the provisions of Part XXVIII of the Local Government Act:—

Dudley Hall, of Warroora Station;  
Michael Meecham, of Quobba Station;  
Brian Patrick Moore, of Brickhouse Station.

A. J. TAYLOR,  
Shire Clerk.

## CITY OF COCKBURN.

Ranger.

IT is hereby notified for public information that Mr. David William Goring has been appointed Ranger for the City of Cockburn as from 31 August 1981.

The appointment of Mr. Lars Anders Lindgren is cancelled as from 4 September 1981.

A. J. ARMAREGO,  
Town Clerk.

## LOCAL GOVERNMENT ACT 1960-1981.

Shire of Moora.

Relief Building Surveyor.

IT is hereby notified for public information that Mr. John Smith has been appointed Building Surveyor (Relieving) for the Shire of Moora for the period 3 September to 27 November 1981 (inclusive).

J. N. WARNE,  
Shire Clerk.

## SHIRE OF COOLGARDIE.

NOTICE is hereby given for public information that Mr Telford Lionel Pedretti, was on 24 August 1981 appointed Acting Shire Clerk to the Shire of Coolgardie for the period 21 September 1981 to 30 November 1981 in the absence of William Francis Moore, Shire Clerk Supervisor.

Dated at Coolgardie the 31st day of August, 1981.

C. J. TREE,  
Shire President.

## LOCAL GOVERNMENT ACT 1960-1981.

Shire of Bruce Rock.

Memorandum of Imposing Rates.

To whom it may concern:

AT a meeting of the Bruce Rock Shire Council held on 13 August 1981, it was resolved that the undermentioned rates and charges be levied on the unimproved values of properties within the Shire of Bruce Rock for the 1981-1982 financial year.

E. G. McCARTHY,  
President.

H. J. MURPHY,  
Shire Clerk.

## Schedule of Rates Levied.

General Rates:—

Townsite 12c in the \$.

Rural areas 1.143c in the \$.

Rubbish Rates: Bruce Rock Townsite \$31.20 per annum.

## LOCAL GOVERNMENT ACT 1960-1981.

HEALTH ACT 1911-1979.

Shire of Roebourne.

Memorandum of Imposing Rates.

AT a meeting of the Roebourne Shire Council, held on 29 July 1981, it was resolved that the rates and charges specified hereunder should be imposed on all rateable property within the district of the Municipality, in accordance with the provisions of the Local Government Act 1960-1981 and the Health Act 1911-1979.

Dated this 26th day of August, 1981.

R. M. CRANE,  
President.

F. GOW,  
Shire Clerk.

## Schedule of Rates and Charges.

General Rates:

25 cents in the dollar on the gross rental value of rateable property.

4 cents in the dollar on the unimproved value of pastoral leases, mining claims and mining leases.

Minimum Rates: \$40.00 for each assessment in all townsites, except Cossack where it shall be \$10.00 for each assessment.

Rubbish Charges—Unrated Properties:

In respect of properties within the Shire of Roebourne which are exempt from rating and from which refuse is removed:—

- (1) Eighty cents (80) for each daily emptying by the Shire of Roebourne of a regulation size receptacle provided by an occupier or owner.
- (2) Four dollars (\$4.00) per cubic yard for the removal by the Shire of Roebourne of other trade refuse.

## LOCAL GOVERNMENT ACT 1960-1981.

HEALTH ACT 1911-1979.

Shire of Wickepin.

Memorandum of Imposing Rates and Charges.

AT a meeting of the Shire of Wickepin held on Friday 14 August 1981, it was resolved that the Rates and Charges specified hereunder, should be imposed on all rateable property within the District of the Municipality in accordance with the provisions of the Local Government Act 1960-1981 and the Health Act 1911-1979 for the year ending 30 June, 1982.

Dated this 14th day of August, 1981.

H. M. LANG,  
President.

W. I. WEIR,  
Shire Clerk.

## Schedule of Rates and Charges Levied.

Rates:

North, South, Central and West Wards 5 cents in the \$ on unimproved valuation, subject to a minimum rate of \$40 per holding.

Townsites of Harrismith, Tincurrin and Toolibin, 22 cents in the \$ on annual values, subject to a minimum rate of \$20 per lot.

Wickepin and Yealering Townsites, 22 cents in the \$ on annual values subject to a minimum rate of \$40 per lot.

Service Charges:

Rubbish Removals Wickepin \$40 per annum.  
Yealering \$20 per annum.

Sullage Water 2 cents per gallon subject to a minimum charge of \$25 per calander month.

Note: A discount of Ten per centum (10%) per annum will be allowed on all current rates paid not later than 31 October 1981, subject to such payment not being reduced below the minimum rate applicable.

Penalty: A penalty of 10% on all rates not paid prior to 31 January 1982 will be imposed.

## LOCAL GOVERNMENT ACT 1960-1981.

Shire of East Pilbara.

Memorandum of Imposing Rates.

To whom it may concern:

AT a meeting of the East Pilbara Shire Council held on 21 July 1981 it was resolved that the Rates and Charges specified hereunder should be imposed on all rateable property within the boundaries of the Shire of East Pilbara in accordance with the provisions of the Local Government Act 1960-1981.

R. A. DANIELS,  
President.

J. M. READ,  
Shire Clerk.

## Schedule of Rates Levied.

General Rate:

8.16c in the dollar on annual values.

7.6c in the dollar on unimproved capital values.

Minimum Rate: \$34.95 on any lot, location on other piece of land.

Rubbish Removals:

Marble Bar and Nullagine Townsites:

Residences: \$80 per annum for one removal weekly.

Businesses: \$120 per annum for two removals weekly.

Newman Townsite:

Residences: \$90 per annum.

Bulk Removal Service: \$13.46 per service per week.

LOCAL GOVERNMENT ACT 1960-1981.  
HEALTH ACT 1911-1979.

City of Cockburn.

Memorandum for Imposing Rates for Financial  
Year 1981-1982.

AT a meeting of the City of Cockburn held on 17 August 1981, it was resolved that the rates and charges specified hereunder shall be imposed on all rateable property within the district of the Municipality, in accordance with the provisions of the Local Government Act 1960-1981 and the Health Act 1911-1979.

Dated this 18th day of August, 1981.

D. F. MIGUEL,  
Mayor.  
A. J. ARMAREGO,  
Town Clerk.

Schedule of Rates and Charges Levied.

General Rate: 1.29 cents in the dollar on unimproved capital values.

Urban Farmland Rate: 0.98 cents in the dollar on unimproved capital values.

Minimum Rate: \$40 per annum.

Rubbish Charge: \$42 per annum.

Penalty: A penalty of 10 per cent will be charged on all rates remaining unpaid after 31 January 1982.

LOCAL GOVERNMENT ACT 1960-1981.  
HEALTH ACT 1911-1979.

Shire of Cranbrook.

Memorandum of Imposing Rates.

To whom it may concern:

AT a meeting of the Cranbrook Shire Council held on 21 August 1981, it was resolved that the Rates and Charges specified hereunder be imposed on all rateable property within the district of the Shire of Cranbrook for the year ended 30 June 1982, in accordance with the provisions of the Local Government Act 1960-1981, and the Health Act 1911-1979.

Dated this 21st day of August, 1981.

R. C. WARD,  
President.  
B. R. GENONI,  
Shire Clerk.

Schedule of Rates and Charges Levied.

General Rate: 1.35 cents in the dollar on Unimproved Values.

Urban Farm Land Rate: .54 cents in the dollar on Unimproved Values.

Minimum Rate: \$40 per assessment.

Discount: A discount of 5 per cent will be allowed on the current rate if payment is made within 35 days of the date of assessment.

Rubbish Removal Charge: (Central Ward) \$34 per annum and \$1.00 per removal where the service is not charged annually. The charge for pensioners as defined under section 561 (aa) of the Local Government Act 1960-1981, and holding a Health Benefit Card shall be one half of the rate otherwise charged.

LOCAL GOVERNMENT ACT 1960-1981.  
HEALTH ACT 1911-1979.

Shire of Meekatharra.

Memorandum of Imposing Rates.

To whom it may concern:

AT a meeting of the Meekatharra Shire Council held on 24 August 1981, it was resolved that the rates and charges specified hereunder shall be imposed on all rateable property within the Municipality in accordance with the provisions of the Local Government Act 1960-1981 and the Health Act 1911-1979.

Dated this 26th day of August 1981.

E. J. LLOYD,  
President.  
L. P. STRUGNELL,  
Shire Clerk.

Schedule of Rates and Charges Levied.

General Rate:

Unimproved Values—\$0.055 in the dollar.

Gross Rental Values—\$0.22 in the dollar.

Minimum Rate—\$40.00 per assessment.

Rubbish Charges:

Domestic: two weekly services \$52.00 per annum.

Commercial A—two weekly services \$100.00 per annum.

Commercial B—two weekly services \$175.00 per annum.

Commercial C—6 weekly services \$350.00 per annum.

Rubbish Tip fees—\$52.00 per annum.

The charge for pensioners, being a pensioner registered as an entitled pensioner under the Pensioners (Rates, Rebates and Deferments) Act, is \$26.00 per annum.

LOCAL GOVERNMENT ACT 1960-1981.

HEALTH ACT 1911-1979.

Shire of Ravensthorpe.

Memorandum of Imposing Charges.

To whom it may concern.

AT the meeting of the Shire of Ravensthorpe held on 20 August 1981 it was resolved that the charges as specified in the *Government Gazette* of 31 July 1981 be amended as follows:—

Ravensthorpe—

Sanitary—\$155.00 per annum per pan.

Rubbish—\$24.00 per annum per bin.

Hopetoun—

Sanitary—\$52.00 per annum per pan.

Rubbish—\$24.00 per annum per bin.

Dated this 20th day of August, 1981.

J. S. LAWRENCE,  
President.  
K. C. WILLIAMS,  
Shire Clerk.

LOCAL GOVERNMENT ACT 1960-1981.

Shire of Laverton.

Memorandum of Imposing Rates.

To whom it may concern:

AT a meeting of the Laverton Shire Council held on 20 August 1981, it was resolved that the rates specified hereunder should be imposed on all rateable property within the Shire of Laverton in accordance with the provisions of the Local Government Act 1960-1981.

Dated this 21st day of August, 1981.

A. J. COLLOPY,  
President.  
P. J. RODGERS,  
Shire Clerk.

Schedule of Rates Levied.

0.25 cents in the dollar on gross rental values.

0.075 cents in the dollar on unimproved value.

Minimum rate of \$40 per annum on each lot or assessment.

Rubbish Removals

\$75 per annum—residential twice weekly service.

\$180 per annum—commercial properties daily service.

Electricity concession—1.25% on gross sales.

Gas concession—0.25% on gross sales.

## LOCAL GOVERNMENT ACT 1960-1981.

## HEALTH ACT 1911-1979.

Town of Kwinana.

## Memorandum of Imposing Rates and Charges.

AT a meeting of the Kwinana Town Council held 27 August 1981 it was resolved that the rates and charges specified hereunder should be imposed on all rateable property within the municipality for the period 1 July 1981 to 30 June 1982 in accordance with the Local Government Act 1960-1981 and Health Act 1911-1979.

Dated this 31st day of August, 1981.

F. G. J. BAKER,  
Mayor.

L. G. BAKER,  
Town Clerk.

## Schedule.

General Rate—1.55 cents in the dollar on unimproved values.

Urban Farmland Rate—1.085 cents in the dollar on unimproved values.

Rubbish Charge—\$37 per annum—weekly service.

Sanitary Charge—\$70 per annum—weekly service.

Discount: A discount of 10% shall be allowed in respect of current rates payments received by 16 October 1981, or within 30 days of the date of service of the rate notice provided no arrears are outstanding.

Furthermore and pursuant to section 550A of the Local Government Act 1960-1981 the Council of the Town of Kwinana resolved to impose a penalty of 10% as specified in the Local Government Act (Unpaid Rates) Regulations 1979 on all rates in arrears as at 31 January 1982 other than rates attributable to a property owned by an entitled pensioner under the Pensioners (Rates Rebates and Deferments) Act 1976.

## LOCAL GOVERNMENT ACT 1960-1981.

Shire of Coolgardie.

To whom it may concern:

AT a meeting of the Shire of Coolgardie held on 24 August 1981, it was resolved that the rates specified hereunder be levied on all rateable land within the Shire of Coolgardie in accordance with the provisions of the Local Government Act 1960-1981.

Dated this 28th day of August, 1981.

C. J. TREE,  
President.

W. F. MOORE,  
Shire Clerk Supervisor.

## Schedule of Rates Levied.

General Rates:

22 cents in the Dollar on Annual Values.

5.1 cents in the Dollar on Unimproved Values.

1.25% Electricity Concessionaire.

\$25.00 Minimum Rate on any Lot or Land.

Rubbish Removals:

Residential—\$38.80 per annum for removal of 2 bins once per week.

Commercial—42c per bin removed.

Sanitary Pans—\$1.80 per pan removed.

## LOCAL GOVERNMENT ACT 1960-1981.

HEALTH ACT 1911-1979.

COUNTRY TOWNS SEWERAGE ACT 1948-1978.

Shire of Dalwallinu.

## Memorandum of Imposing Rates.

To whom it may concern:

AT a meeting of the Dalwallinu Shire Council held on 25 August 1981, it was resolved that the rates specified hereunder should be imposed on all rateable property within the district of the Municipality in

accordance with the provisions of the Local Government Act 1960-1981, Health Act 1911-1979 and Country Towns Sewerage Act 1948-1978.

Dated this 28th day of August, 1981.

D. E. STANLEY,  
President.

## Schedule of Rates Levied.

General Rate in Rural Areas:—4.85 cents in the dollar on the Unimproved Value.

General Rate in Townsites:—13.60 cents in the dollar on Gross Rental Value.

Minimum Rate:—Dalwallinu Townsite, forty dollars (\$40) per lot. All other Townsites, thirty dollars (\$30) per lot.

Discount:—5 per cent discount on General Rates only paid on or before 30 September 1981.

Penalty:—10 per cent will be imposed on all rates unpaid as at 31 January 1982.

Sewerage Rate in Prescribed Area being part of Dalwallinu Townsite:—7.32 cents in the dollar on Gross Rental Value. Minimum rate twenty dollars (\$20) per lot.

Rubbish Removal Charges:—A rubbish removal charge of \$50 per annum within all townsites for a once weekly service and \$25 per annum for each additional service.

Sullage Removal Charges:—An initial charge of \$20 plus \$4 per 450 litres within the prescribed area and \$16 plus \$3 per 450 litres outside the prescribed sewerage area plus 45 cents per kilometre one way within the Shire and 45 cents per kilometre each way outside the Shire.

Septic Tanks:—\$30 per tank per pumping-out within the prescribed sewerage area and \$25 outside the prescribed area plus 45 cents per kilometre.

## LOCAL GOVERNMENT ACT 1960-1981.

HEALTH ACT 1911-1979.

Shire of Harvey.

Memorandum of Imposing Rates and Charges  
1981-1982.

To whom it may concern:

AT a meeting of the Harvey Shire Council, held on 25 August 1981 it was resolved that the rates and charges specified hereunder should be imposed on all rateable property within the district of the Municipality of the Shire of Harvey in accordance with the provisions of the Local Government Act 1960-1981, and the Health Act 1911-1979.

Dated this 31st day of August, 1981.

T. G. STANIFORD,  
Shire President.

L. A. VICARY,  
Shire Clerk.

## Schedule of Rates Levied.

General Rate:

1.466 cents in the dollar on Unimproved Values.

14.312 cents in the dollar on Gross Rental Value.

Minimum Rate: \$40.00 per assessment.

Rubbish Removal Charge: \$24.50 per annum for removal of one standard size bin per week.

Penalty: A penalty of 5% will be imposed on rates outstanding at 31 January 1982 excluding Pensioner Deferred Rates.

## LOCAL GOVERNMENT ACT 1960-1981.

Shire of Murchison.

To whom it may concern:

AT a meeting of the Council of the Shire of Murchison held on 21 August 1981, it was resolved that the rates specified hereunder should be imposed on all rateable property within the district of the Shire of Murchison in accordance with the provisions of the above Act.

Dated this 21st day of August, 1981.

H. M. J. FOULKES-TAYLOR,  
President.

A. R. ATKINSON,  
Shire Clerk.

## Schedule of Rates.

General Rate: 7.25c in the dollar Unimproved Capital Value throughout the district.

Discount: A discount of 10% will be allowed if rates paid within 35 days of assessment.

Penalty: A 10% penalty will apply if rates are not paid by 31 January 1982, as per section 550A of the Local Government Act.

Assessment Fee: A nominal fee of \$20 will be charged for each assessment.

Details of the Loan and Estimates as required by section 609 are open for inspection at the office of the Council, 9 Coleville Crescent, Spearwood, during business hours for thirty-five days after the publication of this notice.

Dated this 18th day of August, 1981.

D. F. MIGUEL,  
Mayor.

A. J. ARMAREGO,  
Town Clerk.

## LOCAL GOVERNMENT ACT 1960-1981.

## HEALTH ACT 1911-1979.

## Memorandum of Imposing Rates, 1981-1982.

To whom it may concern:

AT a meeting of the Serpentine Jarrahdale Shire Council held on 24 August 1981 it was resolved that the rates and charges specified hereunder be imposed on all rateable property within the Shire of Serpentine Jarrahdale in accordance with the Local Government Act 1960-1981 and the Health Act 1911-1979, for the period 1 July 1981 to 30 June 1982.

Dated this 28th August, 1981.

H. C. KENTISH,  
President.

L. E. MANN,  
Shire Clerk.

## Schedule of Rates and Charges.

General Rate: 0.866 cents in the dollar on unimproved values and 28.125 cents in the dollar on gross rental values.

Urban Farmland Rate: 0.585 cents in the dollar on the unimproved values of all properties declared as Urban Farmland.

Minimum Rate: \$40.00 per assessment per lot.

## Differential Rates:

1.0c in the dollar Byford cited P.492 of the *Government Gazette* published 3/3/72.

0.05c in the dollar Byford cited P.3251 of the *Government Gazette* 9/9/77.

0.5c in the dollar Mundijong Townsite cited P.2515 of the *Government Gazette* published 18/6/71.

0.5c in the dollar Jarrahdale Townsite cited P.2150 of the *Government Gazette* published 18/1/71.

0.5c in the dollar Serpentine Townsite cited P.2151 of the *Government Gazette* published 18/6/71.

Discount: A discount of 10% will apply on all current rates if all rates and charges are received in full within 21 days from the date of service of the rate notice.

Penalty: A penalty rate of 10% will apply to all rates, other than pensioners deferred, in arrears as at 31 January 1982.

Rubbish Charges: \$36.00 per annum per service for all residences and commercial businesses in Serpentine, Mundijong, Jarrahdale and Byford and for those properties serviced outside of these areas.

## LOCAL GOVERNMENT ACT 1960-1981.

## City of Cockburn.

## Notice of Intention to Borrow.

## Proposed Loan (No. 102) of \$32 000.

PURSUANT to section 610 of the Local Government Act 1960-1981, the City of Cockburn hereby gives notice, that it proposes to borrow money by the Sale of Debentures on the following terms and for the following purposes: \$32 000 for a period of five (5) years at an interest rate applicable at time of borrowing as approved by the Treasury Department, repayable at the office of the Council, Coleville Crescent, Spearwood, by ten (10) equal half-yearly instalments of principal and interest. Purpose: Purchase of Plant and Equipment.

Details of the Loan and Estimates as required by section 609 are open for inspection at the office of the Council, 9 Coleville Crescent, Spearwood, during business hours for thirty-five (35) days after the publication of this notice.

Dated this 18th day of August, 1981.

D. F. MIGUEL,  
Mayor.

A. J. ARMAREGO,  
Town Clerk.

## LOCAL GOVERNMENT ACT 1960-1981.

## City of Cockburn.

## Notice of Intention to Borrow.

## Proposed Loan (No. 103) of \$313 500.

PURSUANT to section 610 of the Local Government Act 1960-1981, the City of Cockburn hereby gives notice, that it proposes to borrow money by the Sale of Debentures on the following terms and for the following purposes: \$313 500 for a period of fifteen (15) years at an interest rate applicable at time of borrowing as approved by the Treasury Department, repayable at the office of the Council, Coleville Crescent, Spearwood, by thirty (30) equal half-yearly instalments of principal and interest. Purpose: Roadworks.

Details of the Loan and Estimates as required by section 609 are open for inspection at the office of the Council, 9 Coleville Crescent, Spearwood, during business hours for thirty-five (35) days after the publication of this notice.

Dated this 18th day of August, 1981.

D. F. MIGUEL,  
Mayor.

A. J. ARMAREGO,  
Town Clerk.

## LOCAL GOVERNMENT ACT 1960-1981.

## City of Cockburn.

## Notice of Intention to Borrow.

## Proposed Loan (No. 101) of \$100 000.

PURSUANT to section 610 of the Local Government Act 1960-1981, the City of Cockburn hereby gives notice that it proposes to borrow money by the Sale of Debentures on the following terms and for the following purposes: \$100 000 for a period of five (5) years at an interest rate applicable at time of borrowing as approved by the Treasury Department, repayable at the office of the Council, Coleville Crescent, Spearwood, by ten (10) equal half-yearly instalments of principal and interest. Purpose: Purchase of Plant and Equipment.

## LOCAL GOVERNMENT ACT 1960-1981.

## City of Cockburn.

## Notice of Intention to Borrow.

## Proposed Loan (No. 104) of \$54 500.

PURSUANT to section 610 of the Local Government Act 1960-1981, the City of Cockburn hereby gives notice, that it proposes to borrow money by the Sale of Debentures on the following terms and for the following purposes: \$54 500 for a period of fifteen (15) years at an interest rate applicable at time of borrowing as approved by the Treasury Department, repayable at the office of the Council, Coleville Crescent, Spearwood, by



thirty (30) equal half-yearly instalments of principal and interest. Purpose: Construction of Parks, Gardens and Buildings.

Details of the Loan and Estimates as required by section 609 are open for inspection at the office of the Council, 9 Coleville Crescent, Spearwood, during business hours for thirty-five (35) days after the publication of this notice.

Dated this 18th day of August, 1981.

D. F. MIGUEL,  
Mayor.  
A. J. ARMAREGO,  
Town Clerk.

---

LOCAL GOVERNMENT ACT 1960-1981.

Town of Claremont.

Notice of Intention to Borrow.

Proposed Loan (No. 127) of \$80 000.

PURSUANT to section 610 of the Local Government Act 1960-1981 the Council of the Town of Claremont hereby gives notice that it proposes to borrow the sum of \$80 000 for ten (10) years, repayable at Claremont, by twenty (20) equal half-yearly payments of principal and interest. Purpose: Alterations and Additions to Lake Claremont Golf Clubhouse.

Plans, specifications and estimates as required by section 609 are open for inspection at the office of the Council, 308 Stirling Highway, Claremont, during business hours for thirty-five (35) days after the publication of this notice.

Dated this 4th day of September, 1981.

B. H. HOUSTON,  
Mayor.  
A. R. MOORE,  
Acting Town Clerk.

---

LOCAL GOVERNMENT ACT 1960-1981.

Town of Claremont.

Notice of Intention to Borrow.

Proposed Loan (No. 128) of \$20 000.

PURSUANT to section 610 of the Local Government Act 1960-1981 the Council of the Town of Claremont hereby gives notice that it proposes to borrow the sum of \$20 000 for five (5) years repayable at Claremont, by ten (10) equal half-yearly payments of principal and interest. Purpose: Construction of two (2) hard surfaced tennis courts for public use adjacent to Claremont Tennis Club.

Plans, specifications and estimates as required by section 609 are open for inspection at the office of the Council, 308 Stirling Highway, Claremont, during business hours for thirty-five (35) days after the publication of this notice.

Dated this 4th day of September, 1981.

B. H. HOUSTON,  
Mayor.  
A. R. MOORE,  
Acting Town Clerk.

---

LOCAL GOVERNMENT ACT 1960-1981.

Town of East Fremantle.

Notice of Intention to Borrow.

Proposed Loan (No. 131) of \$90 000.

PURSUANT to section 610 of the Local Government Act 1960-1981 the Town of East Fremantle hereby gives notice that it proposes to borrow, by the sale of debentures, money on the following terms: \$90 000 for 15 years repayable to the State Government Insurance Office, Perth, by 30 equal half-yearly instalments of principal and interest (the repayments of this Loan will be met by Mr. A. Risco under the terms of a lease agreement and will be no charge to the Ratepayers of East Fremantle). Purpose: Alterations and additions to premises on Part Lots 1 and 2 Riverside Road, East Fremantle.

(4)—14271

Plans, specifications, estimate of the cost thereof and statement required by section 609 are open for inspection of ratepayers at the office of the Town of East Fremantle between the hours of 9 a.m. and 4 p.m. Mondays to Fridays and for 35 days after the publication of this notice.

Dated the 4th day of September, 1981.

I. G. HANDCOCK,  
Mayor.  
M. G. COWAN,  
Town Clerk.

---

LOCAL GOVERNMENT ACT 1960-1981.

Town of Geraldton.

Notice of Intention to Borrow.

Proposed Loan (No. 176) of \$49 000.

PURSUANT to section 610 of the Local Government Act 1960-1981, the Geraldton Town Council hereby gives notice of its intention to borrow money by the sale of a debenture on the following terms and for the following purpose: \$49 000 repayable over a ten year period in equal half-yearly instalments. Purpose: Footpaths, construction and upgrading.

Plans, specifications and estimates as required by section 609 of the Act are open for inspection at the Civic Centre, Cathedral Avenue, Geraldton during normal office hours for a period of thirty-five (35) days following publication of this notice.

Dated this 31st day of August, 1981.

L. J. HARRIS,  
Mayor.  
J. W. FLATOW,  
Town Clerk.

---

LOCAL GOVERNMENT ACT 1960-1981.

Shire of Collie.

Notice of Intention to Borrow.

Proposed Loan (No. 86) of \$44 000.

PURSUANT to section 610 of the Local Government Act 1960-1981, the Shire of Collie hereby gives notice of its intention to borrow money by the sale of debentures on the following terms and for the following purpose: \$44 000 for a period of seven (7) years repayable by equal half yearly instalments of principal and interest. Purpose: Purchase of Plant and Equipment.

Plans, specifications and estimates of costs as required by section 609 of the Act are open for inspection at the Office of the Council during normal office hours for a period of thirty-five (35) days after publication of this notice.

Dated this 1st day of September, 1981.

J. L. MUMME,  
President.  
L. J. CHRISTINGER,  
Shire Clerk.

---

LOCAL GOVERNMENT ACT 1960-1981.

Shire of Cranbrook.

Notice of Intention to Borrow.

Proposed Loan (No. 70) of \$50 000.

PURSUANT to section 610 of the Local Government Act 1960-1981 the Council of the Shire of Cranbrook hereby gives notice of its intention to borrow money by the sale of a single debenture on the following terms and for the following purpose: \$50 000 for 20 years repayable by 40 equal half yearly instalments of principal and interest. Purpose: Extensions Frankland Hall.

Plans, specifications and estimates as required by section 609 of the Act are available for inspection at the Office of the Council during normal office hours for 35 days after the publication of this notice.

Dated this 2nd day of September, 1981.

R. C. WARD,  
President.  
B. R. GENONI,  
Shire Clerk.

## LOCAL GOVERNMENT ACT 1960-1981.

Shire of Gnowangerup.

Notice of Intention to Borrow.

Proposed Loan (No. 234) of \$100 000.

PURSUANT to section 610 of the Local Government Act 1960-1981 the Gnowangerup Shire Council hereby gives notice of its intention to borrow money by the sale of debentures on the following terms: One hundred thousand dollars for a period of seven years at the ruling rate of interest repayable at the office of the Council, Gnowangerup, by 14 equal half-yearly instalments of principal and interest with the balance owing on expiry of the loan and for the following purpose: Generating Unit, Minor Capital Works and Tools and Equipment, Bremer Bay Electrical Undertaking.

Plans, specifications and estimates of costs as required by section 609 of the Act are open for inspection at the offices of the State Energy Commission, Perth, during office hours for 35 days after the publication of this notice.

Interest and principle of the above loan will be paid by the State Energy Commission and therefore there will be no charge on ratepayers for the repayment of the loan.

Dated this 4th day of September, 1981.

R. K. BROWN,  
President.  
R. J. SIMS,  
Shire Clerk.

**CORRIGENDUM.**

## LOCAL GOVERNMENT ACT 1960-1981.

Shire of Kellerberrin.

Notice of Intention to Borrow.

Proposed Loan (No. 93) of \$16 000.

IT is hereby notified that the term of the above Loan Advertisement in the *Government Gazette* of 17 July 1981 on Page 2887 has been reduced from Twenty years (20) to Fifteen years (15).

P. J. LEAKE,  
President.  
N. D. FIMMANO,  
Shire Clerk.

## LOCAL GOVERNMENT ACT 1960-1981.

Shire of Kojonup.

Proposed Loan (No. 97) of \$25 000.

PURSUANT to section 610 of the Local Government Act 1960-1981, the Shire of Kojonup hereby gives notice that it proposes to borrow by the sale of debentures on the following terms and for the following purposes: \$25 000 (Twenty Five Thousand Dollars) for a period of 5 years repayable at Kojonup by equal half-yearly instalments of Principal and Interest. Purpose: Purchase of Plant.

Estimates as required by section 609 are open for inspection at the Office of the Council during office hours for 35 days after publication of this notice.

Dated this 4th day of September, 1981.

M. G. HARRISON,  
President.  
P. DURTANOVICH,  
Shire Clerk.

## LOCAL GOVERNMENT ACT 1960-1981.

Shire of Manjimup.

Notice of Intention to Borrow.

Proposed Loan (No. 134) of \$100 000.

PURSUANT to section 610 of the Local Government Act 1960-1981, the Manjimup Shire Council hereby gives notice that it proposes to borrow money by the sale of debentures on the following terms and for the following purposes: \$100 000 for a period of 15 years repayable at the Office of the Council in Manjimup by 30 equal half-yearly instalments of principal and

interest. Purpose: To construct three Squash Courts and irrigate a golf course; i.e. Manjimup Country Club Inc. grounds.

Plans, specifications, estimate of costs and statements as required by section 609 of the Act are open for inspection by ratepayers at the Office of the Council during normal office hours for a period of 35 days after this notice.

Note: The repayments for the whole of this loan will be paid to Council by the Manjimup Country Club Inc.; there being no loan repayment costs to be met by ratepayers in respect to this proposal.

C. S. CROMBIE,  
President.  
M. DUNN,  
Shire Clerk.

## LOCAL GOVERNMENT ACT 1960-1981.

Shire of Tambellup.

Notice of Intention to Borrow.

Proposed Loan (No. 75) of \$53 000.

PURSUANT to section 610 of the Local Government Act 1960-1981, the Tambellup Shire Council hereby gives notice that it proposes to borrow money by sale of debentures on the following terms and for the following purposes: \$53 000 for a period of five (5) years at the current interest rate, payable at the Office of the Council, Tambellup, by ten (10) equal half yearly instalments of principal and interest. Purpose: Plant Purchases.

Plans and specifications as required under section 609 of the Local Government Act 1960-1981, are available for inspection at the Office of the Council during normal office hours for a period of 35 days after publication of this notice.

Dated this 24th day of August, 1981.

A. C. N. ANDERSON,  
President.  
P. DURTANOVICH,  
Shire Clerk.

## LOCAL GOVERNMENT ACT 1960-1981.

Shire of West Kimberley.

Notice of Intention to Borrow.

Proposed Loan (No. 95) of \$100 000.

PURSUANT to section 610 of the Local Government Act 1960-1981 the West Kimberley Shire Council proposes to borrow money by the sale of debentures on the following terms and conditions: Proposed Loan 95, \$100 000 for a period of ten years at the ruling rate of interest and repayable by twenty equal half yearly instalments. Purpose: Purchase of land and buildings.

Plans, specifications and estimates as required by section 609 are available for inspection at the office of Council during business hours for 35 days after publication of this notice.

Dated this 26th day of August, 1981.

P. R. KNEEBONE,  
President.  
J. F. BOSCHETTI,  
Shire Clerk.

## LOCAL GOVERNMENT ACT 1960-1981.

City of Perth.

Sale of Land.

Department of Local Government,  
Perth, 26 August 1981.

LG: P-4-6.

IT is hereby notified for public information that His Excellency the Governor has directed under the provisions of section 266 of the Local Government Act 1960-1981, that the City of Perth may sell portion of Perthshire Locations Ac, Ay and I and being Lot 101 on Diagram 49865 and being the whole of the land comprised in Certificate of Title Volume 1430 Folio 930 to the Western Australian Deaf Society (Inc.) by private treaty.

P. FELLOWES,  
Secretary for Local Government.

LOCAL GOVERNMENT ACT 1960-1981.

Shire of Meekatharra.

Loan.

Department of Local Government,  
Perth, 26 August 1981.

LG: MK-3-8.

IT is hereby notified for public information that His Excellency the Governor has approved of upgrading the generating plant and distribution system and other works associated with the Meekatharra Electricity Undertaking by the State Energy Commission being declared a work and undertaking for which money may be borrowed under the provisions of Part XXVI of the Local Government Act 1960-1981, by the Shire of Meekatharra.

P. FELLOWES,  
Secretary for Local Government.

LOCAL GOVERNMENT ACT 1960-1981.

City of Bunbury.

Closure of Private Street.

Department of Local Government,  
Perth, 15 July 1981.

LG: BY-4-14.

IT is hereby notified for public information that His Excellency the Governor has approved under the provisions of section 297A of the Local Government Act 1960-1981 the resolution passed by the City of Bunbury that the private street which is described as being portion of Bunbury Lot 438 and being the land coloured brown and marked R.O.W. on Plan 8281 and being part of the land comprised in Certificate of Title Volume 1299 Folio 805 be closed and the land contained therein be allocated to the adjoining lots 15 and 16 Mangles Street, Bunbury, as shown in the Schedule hereunder.

P. FELLOWES,  
Secretary for Local Government.

Schedule.

Diagram No. 61691.

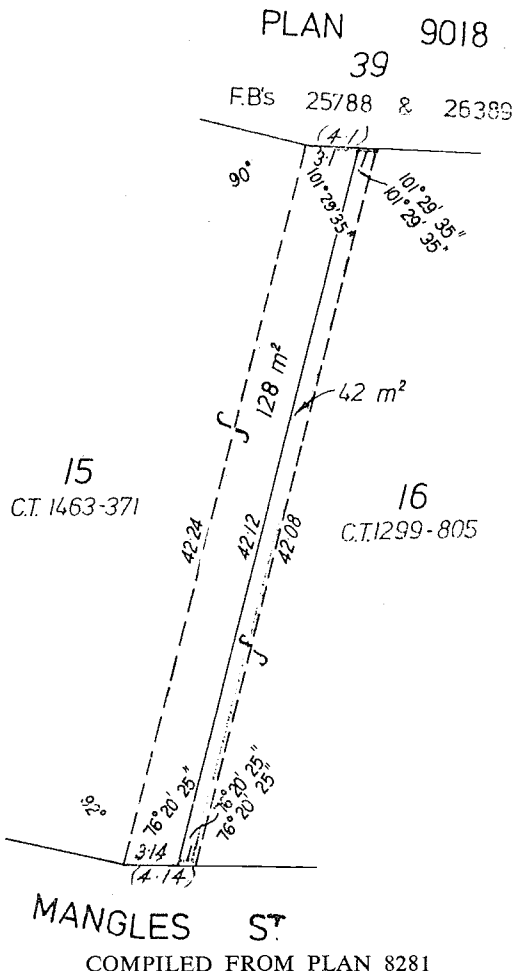

LOCAL GOVERNMENT ACT 1960-1981.

Shire of Swan.

Closure of Private Street.

Department of Local Government,  
Perth, 15 July 1981.

LG: SW-4-13A.

IT is hereby notified for public information that His Excellency the Governor has approved under the provisions of section 297A of the Local Government Act 1960-1981 the resolution passed by the Shire of Swan that the private street which is described as being portion of Swan Location 7 and being the land marked R.O.W. on Diagram 5174 and being part of the balance of the land comprised in Certificate of Title Volume 233 Folio 63 be closed and the land contained therein be allocated to the adjoining Lot Pt 111 Great Eastern Highway, Midland, as shown in the Schedule hereunder.

P. FELLOWES,  
Secretary for Local Government.

Schedule.

Diagram No. 61692.

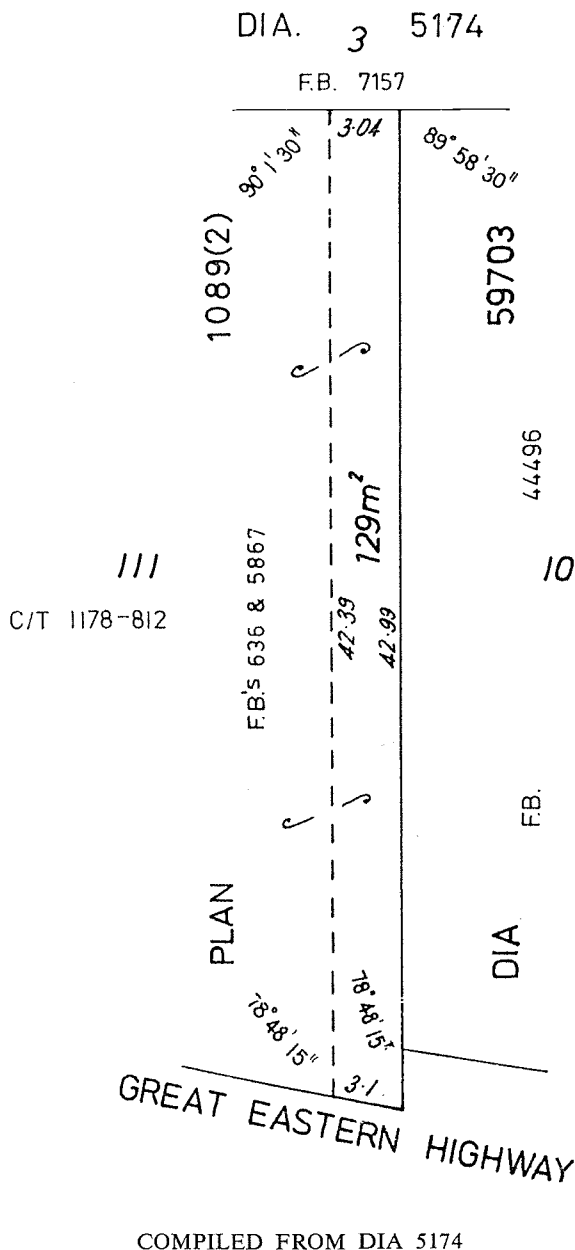

## LOCAL GOVERNMENT ACT 1960-1981.

Shire of Perenjori.

Transfer of Land.

Department of Local Government,  
Perth, 26 August 1981.

LG: PJ-4-6.

IT is hereby notified for public information that His Excellency the Governor has directed under the provisions of section 266 of the Local Government Act 1960-1981, that the Shire of Perenjori may:—

- (1) subdivide Perenjori Lot 127 being land contained in Certificate of Title Volume 1556 Folio 274 under the Town Planning and Development Act 1928, for the purpose of transferring portion of the land as so subdivided; and
- (2) transfer that portion of the land as so subdivided to A. R. & B. J. Turner.

P. FELLOWES,

Secretary for Local Government.

By-law 10 (b), line 2—

“(711.25 mm)” should read “(7/1.25 mm)”.

By-law 11 (b), line 2—

“(710.85 mm)” should read “(7/0.85 mm)”.

P. FELLOWES,

Secretary for Local Government.

## LOCAL GOVERNMENT ACT 1960-1981.

Municipal Election.

Department of Local Government,  
Perth, 2 September 1981.

IT is hereby notified, for general information, in accordance with section 129 of the Local Government Act 1960-1981, that the following person has been elected a Member of the undermentioned Municipality to fill the vacancy shown in the particulars hereunder:—

Date of Election; Member Elected; Surname, Christian Name; Ward; Occupation; How vacancy occurred:  
(a) Effluence of time; (b) Resignation; (c) Death;  
Name of Previous Member; Remarks.

Shire of Boulder.

15/8/81; Jarvis, Patricia Ann; Central; Accountant;  
(b); Kreplins, I. L.; —.

P. FELLOWES,

Secretary for Local Government.

**CORRIGENDUM.**

## LOCAL GOVERNMENT ACT 1960-1973.

Uniform General By-laws.

WHEREAS the notice published under the above heading on pages 5649-5652 of *Government Gazette* (No. 97) dated 20 December 1974 contained two errors, they are corrected as follows.

## LOCAL GOVERNMENT ACT 1960-1981.

## TOWN OF KALGOORLIE (SPECIFIED AREA) ORDER 1981.

MADE by His Excellency the Governor under Section 548 (4) of the Local Government Act.

Citation. 1. This Order may be cited as the Town of Kalgoorlie (Specified Area) Order 1981.

Commencement. 2. This Order shall take effect on and after 1st July, 1981.

Declaration of Specified Area. 3. The portions of the district of the Town of Kalgoorlie as described in the Schedules to this Order are declared to be specified areas to which section 548 (4) of the Local Government Act applies.

By His Excellency's Command,

J. E. A. PRITCHARD,

Acting Clerk of the Council.

## Schedule A.

All that portion of land bounded by lines starting from the northernmost north-eastern corner of Hampton Location 2, (Reserve 3417) and extending south-westerly and south-easterly along boundaries of that Location to the south-eastern corner of Lot 12 as shown on Land Titles Office Plan 12214; thence north-easterly along the south-eastern boundary of that lot to the south-eastern side of Charles Street; and thence north-westerly along that side to the starting point.

Lands and Surveys Public Plans: Kalgoorlie-Boulder and Environs 29.36 and 29.37.

## Schedule B.

All that portion of land bounded by lines starting from the southern corner of the north-eastern severance of Hampton Location 119 and extending generally north-easterly along south-eastern boundaries of that severance to the western corner of Location 118; thence south-easterly along the south-western boundary of that location to the north-western side of the north-eastern section of Premier Street; thence south-westerly along that side to the northern corner of Hannans Suburban Area Lot 165; thence south-westerly along the north-western boundary of that lot and south-westerly along a north-western side of the south-western section of Premier Street to a south-eastern boundary of Kalgoorlie Lot 3618; thence north-easterly, northerly, generally north-westerly and south-westerly along boundaries of that lot to a north-eastern side of Road Number 14488 and thence north-westerly along that side to the starting point.

Lands and Surveys Public Plan: Kalgoorlie-Boulder and Environs 1:2 000, 28.40.

## LOCAL GOVERNMENT ACT 1960-1981.

The Municipality of the City of Fremantle.

## By-Law Relating to Stalls.

IN pursuance of the powers conferred upon it by the abovementioned Act and of all other powers enabling it, the Council of the abovementioned municipality hereby records having resolved on 18 February 1980 to make and submit for confirmation by the Governor the following by-law:—

1. In this By-law:
  - “Authorised Assistant” means a person to whom a permit has been issued under clause 9 of this By-law;
  - “Clerk” means the Town Clerk of the City of Fremantle;
  - “Council” means the Council of the City of Fremantle;
  - “Stall” means a movable or temporarily fixed barrow or cart for the sale of goods, wares, merchandise or services;
  - “Stallholder” means a person in charge of a stall to whom a licence has been issued under this By-law;
  - “Stand” means a position in a place where a stall may be set up.
2. A person shall not set up a stall or conduct business at a stall or any part of a street unless:—
  - (a) that part of a street is a stand; and
  - (b) that person is the stallholder to whom a licence for that stand has been issued by the Council.
3. Every application for a licence shall be in respect of a particular stand for the sale of specified goods and shall:
  - (a) be in writing in the form set out in the First Schedule to this By-law;
  - (b) be accompanied by a plan of the proposed stall including its dimensions and a statement of the materials of which the stall is or is to be constructed;
  - (c) be accompanied by two character references in respect of the stallholder;
  - (d) where the applicant is a corporation the application shall specify the name of a person who is to be the stallholder;
  - (e) state the proposed number of assistants;
  - (f) state the proposed hours of operation.
4. (1) The Council shall not issue a licence if:
  - (a) the provisions of Clause 3 have not been complied with;
  - (b) it is not satisfied that the applicant is reputable and of good character;
  - (c) the prescribed fee has not been paid;
  - (d) a current licence exists for the stand with respect to which the application is made.(2) The Council may refuse to issue a licence to any person for any stall, and shall not be required to state its reasons for such refusal.
5. A licence shall specify:
  - (a) the name and address of the stallholder;
  - (b) the location and number of the stand;
  - (c) the number of assistants (if any) who may assist the stallholder in the conduct of business at the stall;
  - (d) particulars of the goods which may be sold from the stall;
  - (e) particulars of the stall approved of by the Council;
  - (f) the hours of business operation of the stall.
6. Where a licence is issued under this By-law the stallholder named in the licence or a transferee approved of under this By-law and the number of assistants (if any) specified in the licence, and no other person, has the right to set up and conduct business at a stall on the stand with respect to which the licence has been issued.
7. (a) The fee payable for the issue of a licence is \$100.  
(b) The fee payable for the transfer of a licence is \$20.
8. (1) A Stallholder shall:
  - (a) not:
    - (i) employ or use in the conduct of business at a stall more than the number of assistants specified in the licence;
    - (ii) transfer assign or otherwise dispose of the licence except to a transferee approved of under this By-law;
    - (iii) sell from the stall any goods other than those specified in the licence;
    - (iv) cause or permit or suffer any nuisance to exist or continue on or adjacent to the stand specified in the licence;
    - (v) place any advertisement placard poster streamers or sign or signboards, other than price tickets not exceeding 200 sq cm in area, on the stall or any part of the street in which the stand is located;

- (vi) permit any loudhailer microphone or other method of making noise whether of the same kind or not to be used on his stand or elsewhere in relation to his stand;
  - (vii) permit any record tape or radio to be played on his stand or elsewhere in relation to his stand;
  - (viii) use any flap shelf or other device on this stall whereby the dimensions thereof are increased beyond those specified in the licence.
  - (ix) without the prior approval of the Council make any alteration or addition to the stall as approved by the Council.
- (b) ensure that his name and stall number is painted or displayed in a conspicuous place on the stall in letters and figures of not less than 5 cm in height;
- (c) subject to clause 9 personally attend at his stall so long as that stall is in operation;
- (d) keep his stall clean in good repair and properly painted;
- (e) ensure that the stand is kept entirely free from trade and other refuse and rubbish;
- (f) produce his licence to any officer or member of the Council or any police officer when demanded.
8. (2) All provisions of subclause (1) of this clause except paragraph (f) shall be observed by an Authorised Assistant who in the absence of the stallholder from the stand occupies that stand.
- (3) An Authorised Assistant shall produce the permit issued to him under clause 9 to any officer or member of the Council or any police officer when demanded.
9. Where a stallholder by reason of illness, accident or other cause is unable to comply with clause 8 (1) (c) of this By-law the Clerk may issued a permit in writing authorising a person named in the permit to occupy and manage the staff during the hours that the stall is in operation.
10. With the consent of the Council a licence may be transferred to a person approved of by the Council not being a person who is the holder of a current licence. Application for the transfer of a licence shall be made in writing shall be accompanied by two character references relating to the transferee and the Council shall not approve of the transfer if it is not satisfied that the transferee is reputable and of good character.
11. A licence shall be valid for a period of 12 months from the date of issue of the licence. The holder of a licence may apply for a renewal of that licence for a further period of 12 months. Upon application being made for renewal of a licence the holder of the licence shall pay to the Council a fee of \$100 for that renewal.
12. The Council may at any time revoke the licence if in the opinion of the Council the stallholder, an Authorised Assistant or any of his assistants;
- (a) commits an offence against this by-law while conducting business at the stall;
  - (b) is guilty of offensive or unbecoming conduct or behaviour on or near his stand;
  - (c) does not keep the stand on which the stall is set up, the stall or any of its receptacles or fittings clean and tidy;
  - (d) is not at all times clean in habit and appearance while on the stand.
13. Where a licence is revoked under clause 12 the right to occupy the stand and to set up and occupy the stall thereon thereupon ceases and the stallholder shall not be entitled to any refund of fees paid to the Council.
14. A person who fails to comply with any provision of this By-law commits an offence and is liable on conviction to a penalty not exceeding \$100.

---

First Schedule.

Application for Stall Licence.

1. Name and address of applicant.
2. Name and address of person as stallholder (if applicant is a corporation).
3. Location of Stand.
4. Goods to be sold.
5. Proposed number of assistants.

The applicant hereby applies for the issue of a stall licence in respect of the above-mentioned stand for the sale of the abovementioned goods in accordance with and subject to the stalls by-laws of the City of Fremantle.

.....  
Signature of Applicant

Note: This application must be accompanied by:

- (a) Two character references in respect of the stallholder; and
- (b) A plan of the proposed stall (including dimensions) and a statement of the materials of which the stall is or is to be constructed.

Second Schedule.  
City of Fremantle.  
By-Law.  
Stall Licence.

1. Name and Address of Stallholder:
2. (a) Location of Stand:  
(b) Number of Stand:
3. Goods to be sold.
4. Number of Assistants.
5. Particulars of stall approved by the Council.

This licence authorises the stallholder to set up and conduct business at the stall specified for a period of twelve months from the date of the issue hereof subject to and in accordance with the City of Fremantle by-law relating to stalls.

Date of Issue:

For the Council of the City of Fremantle  
.....  
Town Clerk.

Dated this 23rd March, 1981.

The Common Seal of the City of Fremantle  
was hereto affixed in the presence of—

[L.S.]

W. A. McKENZIE,  
Mayor.  
S. W. PARKS,  
City Manager.

Recommended—

JUNE CRAIG,  
Minister for Local Government.

Approved by His Excellency the Governor in Executive Council this 26th day of August, 1981.

J. E. A. PRITCHARD,  
Acting Clerk of the Council.

LOCAL GOVERNMENT ACT 1960-1981.

The Municipality of the City of Fremantle.

By-laws Relating to Movable or Temporarily Fixed Stalls.

IN pursuance of the powers conferred upon it by the abovementioned Act and of all other powers enabling it, the Council of the abovementioned Municipality hereby records having resolved on 18 February 1980, to submit for confirmation by the Governor the repeal of its By-law No. 152 for Regulating Movable or Temporarily Fixed Stalls as published in the *Government Gazette* of 4 October, 1940.

Dated this 22nd day of July, 1981.

The Common Seal of the City of Fremantle was  
hereunto affixed in the presence of—

[L.S.]

W. A. McKENZIE,  
Mayor.  
G. T. FOSTER,  
Acting Town Clerk.

Recommended—

JUNE CRAIG,  
Minister for Local Government.

Approved by His Excellency the Governor in Executive Council this 26th day of August, 1981.

J. E. A. PRITCHARD,  
Acting Clerk of the Council.

LOCAL GOVERNMENT ACT 1960-1981.

The Municipality of the City of Perth.

By-law No. 64—Town Planning Classification or Zoning By-law for the land and/or buildings in the North Perth/Mount Hawthorn/Wembley/Leederville Area being part of the City of Perth Municipal District.

IN pursuance of the powers conferred upon it by the abovementioned Act and of all other powers enabling it the Council of the abovementioned Municipality hereby records having resolved on 16 March 1981, to make and submit for confirmation by the Governor, the following amendments to By-law No. 64:

That the following portions of land shown hereunder:

Portion of Swan Location 388 and being Lot 206 on deposited Plan 3083 and being the whole of the land comprised in Certificate of Title Volume 535 Folio 93

Portion of Swan Location 388 and being Lot 207 on Plan 3083 and being part of the land comprised in Certificate of Title Volume 1030 Folio 193 be and are hereby excised from the No. 1 Zone classification and reclassified and included in the No. 7 Zone classification, and that the North Perth/Mount Hawthorn/Wembley/Leederville Area Zoning Plan No. 64 be and is hereby amended accordingly.

Dated this 4th day of June, 1981.

The Common Seal of the City of Perth was here-  
unto affixed in the presence of—

[L.S.]

F. C. CHANEY,  
Lord Mayor.

G. O. EDWARDS,  
Town Clerk.

Recommended—

JUNE CRAIG,  
Minister for Local Government.

Approved by His Excellency the Governor in Executive Council this 26th day of August, 1981.

J. E. A. PRITCHARD,  
Acting Clerk of the Council.

#### LOCAL GOVERNMENT ACT 1960-1981.

The Municipality of the City of Perth.

By-law No. 64—Town Planning Classification or Zoning By-law for the land and/or buildings in the North Perth/Mount Hawthorn/Wembley/Leederville Area being part of the City of Perth Municipal District.

IN pursuance of the powers conferred upon it by the abovementioned Act and of all other powers enabling it the Council of the abovementioned Municipality hereby records having resolved on 13 April 1981, to make and submit for confirmation by the Governor, the following amendment to By-law No. 64:—

That the following portion of land shown hereunder:

Portion of Swan Location 391 and being Lot 505 on Plan 133 and being the whole of the land contained in Certificate of Title Volume 738 Folio 81 be and is hereby excised from the No. 1 Zone classification and reclassified and included in the No. 16 Zone Classification and that the North Perth/Mount Hawthorn/Wembley/Leederville Area Zoning Plan No. 64 be and is hereby amended accordingly.

Dated this 19th day of May, 1981.

The Common Seal of the City of Perth was here-  
unto affixed in the presence of—

[L.S.]

F. C. CHANEY,  
Lord Mayor.

G. O. EDWARDS,  
Town Clerk.

Recommended—

JUNE CRAIG,  
Minister for Local Government.

Approved by His Excellency the Governor in Executive Council this 26th day of August, 1981.

J. E. A. PRITCHARD,  
Acting Clerk of the Council.

#### DOG ACT 1976-1977.

The Municipality of the City of South Perth.

By-law Relating to Dogs.

By-law No. 3.

IN pursuance of the powers conferred upon it by the abovementioned Act and of all other powers enabling it, the Council of the abovementioned Municipality hereby records having resolved on 22 December 1980, to make and submit for confirmation by the Governor the following amendment to its By-law Relating to Dogs. By-law No. 3, published in the *Government Gazette* of 29 August 1980.

Amendment. A new Clause:

7. A person liable for the control of a dog who permits that dog to be on the foreshore of Melville Water between a prolongation of the southern boundary of Comer Street, Como, and a prolongation of the northern boundary of



Thelma Street, Como, such foreshore being defined as that piece of land lying between the low water mark and the western boundary of Kwinana Freeway, commits an offence.

Dated this 20th day of July, 1981.

The Common Seal of the City of South Perth  
was hereunto affixed in the presence of—

[L.S.]

J. G. BURNETT,  
Mayor.  
P. A. BENNETTS,  
Town Clerk.

Recommended—

JUNE CRAIG,  
Minister for Local Government.

Approved by His Excellency the Governor in Executive Council this 26th day of August, 1981.

J. E. A. PRITCHARD,  
Acting Clerk of the Council.

LOCAL GOVERNMENT ACT 1960-1981.

The Municipality of the Town of Kalgoorlie.

By-Law Relating to Standing Orders.

IN pursuance of the powers conferred upon it by the abovementioned Act and of all other powers enabling it, the Council of the abovementioned Municipality hereby records having resolved on 8 June 1981, to make and submit for confirmation by the Governor an amendment to the By-law Relating to Standing Orders published in the *Government Gazette* on 1 August 1962.

By-law 93 (1) of the by-law is repealed and re-enacted as follows:—

*Quorum of Committees.*

93. (1) At any Meeting of a Committee, a quorum shall consist of not less than half of the number comprising the Committee including the Chairman.

Dated this 7th day of August, 1981.

The Common Seal of the Town of Kalgoorlie  
was affixed hereto in the presence of—

[L.S.]

M. R. FINLAYSON,  
Mayor.  
T. J. O'MEARA,  
Town Clerk.

Recommended—

JUNE CRAIG,  
Minister for Local Government.

Approved by His Excellency the Governor in Executive Council this 26th day of August, 1981.

J. E. A. PRITCHARD,  
Acting Clerk of the Council.

LOCAL GOVERNMENT ACT 1960-1981.

The Municipality of the Shire of Collie.

By-Laws Relating to Motels.

IN pursuance of the powers conferred upon it by the abovementioned Act, the Council of the abovementioned Municipality hereby records having resolved on 9 June 1981, to make and submit for confirmation of the Governor, the following amendment to its By-Laws relating to Motels, published in the *Government Gazette* on 29 December 1972 and amended from time to time thereafter.

1. Clause 10 of the principal by-laws is amended by substituting for the word "ten" in line three, the word "fifty".

Dated this 19th day of June, 1981.

The Common Seal of the Shire of Collie was  
hereto affixed in the presence of—

[L.S.]

J. L. MUMME,  
President.  
L. J. CHRISTINGER,  
Shire Clerk.

Recommended—

JUNE CRAIG,  
Minister for Local Government.

Approved by His Excellency the Governor in Executive Council this 26th day of August, 1981.

J. E. A. PRITCHARD,  
Acting Clerk of the Council.

## LOCAL GOVERNMENT ACT 1960-1981.

## The Municipality of the Shire of Esperance.

## By-laws Relating to the Management and Control of the Esperance Youth and Community Centre.

IN pursuance of the powers conferred upon it by the abovementioned Act and of all other powers enabling it, the Council of the abovementioned Municipality hereby records having resolved on 19 July 1980 to make and submit for confirmation by the Governor the following by-laws:—

1. In these by-laws, unless the context otherwise requires, the following terms shall have the meaning set against them hereunder respectively:—

“Council” means the Council of the Municipality of the Shire of Esperance.

“Attendant” means an officer or employee of the Council duly authorised to perform duties in connection with The Esperance Youth and Community Centre.

“Centre Director” means the person for the time being employed by the Council to control and to manage The Esperance Youth and Community Centre and includes his assistant or deputy.

“The Esperance Youth and Community Centre” (hereinafter referred to as the Centre) means and includes the swimming pool, buildings, structures, facilities, machinery, chattels, furniture, equipment, garden, and parking area erected on Reserve 29727 Corner of Black and Padbury Streets, Esperance.

“Shire Clerk” means the Shire Clerk of the Shire of Esperance.

“The Swimming Pool Section” shall mean the swimming pool, concourse surrounds, walls enclosing same and observation room.

2. (a) The Centre shall be open for admission of the public during such hours and periods as the Council may from time to time determine.

(b) The Centre or any part thereof may, at any time at the discretion of the Centre Director be set aside for the use of certain persons to the exclusion of others, except that the swimming pool section may only be so set aside with the written approval of the Shire Clerk endorsed by Council.

3. (a) Any part of the Centre may be hired during times that the Centre is not to be attended by the Centre Director or an Attendant.

(b) Such hire shall be subject to compliance with the terms and conditions specified by the Council.

(c) The hirer shall be responsible for opening and securing the building. Keys may be collected from the Centre during normal opening hours prior to the function, so long as there are no other bookings, and keys must be returned on the first day the Centre is open for business following the hiring.

(d) At the time of picking up the key the hirer shall pay a key deposit of \$10.00 to be refundable after the return of the key to the Centre.

(e) The hirer shall maintain and keep good order and decent behaviour and shall be solely and entirely responsible for the carrying out of these by-laws and for any damage done to the Centre, and shall pay such damages as shall be assessed by the Council.

(f) The hirer shall, before such time as the Centre is next to be attended by the Centre Director or an Attendant, or by such extended time as may be approved in writing in advance by the Centre Director.

(i) leave the Centre in a clean and tidy condition after the term of hiring;

(ii) remove and place all rubbish in the places so provided within the Centre except decoration materials which shall be carted away.

Any expense incurred by the Council in these respects through neglect of the hirer to comply with this by-law shall be a direct charge against the hirer and such expense shall be paid immediately on demand.

4. The Council may refuse any person admission to the Centre at any time and children under the age of six (6) years shall be refused admission to the swimming pool section unless accompanied by a responsible person over the age of fourteen (14) years.

5. Every person entering the Centre does so at his or her own risk.

6. Every person using the Centre shall obey all reasonable directions of the Centre Director or Attendant with regard to such use.

7. The Centre Director or Attendant may temporarily suspend admission to, or remove from the Centre or any part thereof, any person if, in his opinion, such action is necessary or desirable.

8. If a person shall appear in public and in the opinion of the Centre Director or Attendant, be indecently or insufficiently clad, the Centre Director or Attendant shall direct that person forthwith to resume his or her ordinary clothing and such person shall forthwith comply with that direction.

9. (a) It shall be the duty of the Centre Director or Attendant, who is hereby empowered and directed to refuse admission to or remove, or cause to be removed from the Centre any person who, in the opinion of the Centre Director or Attendant:

(i) is guilty of a breach of any of the provisions of these by-laws; or

(ii) is by his past, or present conduct within or about the Centre undesirable; or

(iii) is under, or apparently under the influence of alcoholic liquor;

(b) It shall be the duty of the Centre Director or Attendant, who is hereby so empowered and directed, to refuse admission to or remove, or cause to be removed from the swimming pool section any person who, in the opinion of the Centre Director or Attendant:—

- (i) is a child under the age of six (6) years and is unaccompanied by a responsible person over the age of fourteen (14) years; or
- (ii) is apparently suffering from any contagious, infectious, offensive disease or skin complaint.

(c) Any such person shall, upon the request of the Centre Director or Attendant to withdraw from the pool premises, quietly and peaceably, do so immediately.

10. Any person who has been refused admission to the Centre or has been requested to leave the Centre and who feels aggrieved by the action of the Centre Director or an Attendant, may appeal to the Council, by letter addressed to the Shire Clerk, against such action. The Council shall consider the objection and give such direction in the matter as it thinks fit. The right of appeal given by this by-law shall not imply any right of action for damages or other remedy against the Council or Centre Director or an Attendant arising out of such refusal of admission or direction to leave the Centre.

11. A person shall not for profit, teach, coach or train any person in the Centre unless with the prior written approval of the Council. Such approval may be subject to conditions and may be withdrawn by the Council at any time.

12. (a) A person, club organiser or association shall not conduct swimming or diving events, carnivals or competitions in the swimming pool section without the prior written approval of the Council.

(b) The Council may grant such approval subject to such conditions as it thinks fit and may, at any time, withdraw such consent.

13. A person, club, association or organisation conducting any carnival or activity at the Centre shall be responsible for the conduct of persons in attendance and shall prevent overcrowding and ensure that no damage is done to the Centre and that these by-laws are observed by persons in attendance.

14. Every person finding, within the Centre, any article which may have been left or lost therein, shall immediately deliver it to the Centre Director or Attendant who shall thereupon register a description of such article and all particulars relating thereto in a book which shall be kept for that purpose, and any person claiming the article, who satisfies the Centre Director or Attendant that he is the lawful owner of the article, shall upon signing a receipt for it, have the article returned to him.

15. All articles left in the Centre and not claimed within a period of three (3) calendar months, shall be disposed of by the Council in any manner acceptable at common law.

16. (a) No male person shall enter any portion of the Centre set apart for females, and no female person shall enter upon any portion of the Centre set apart for males.

(b) No person in the Centre shall, in any way, interfere with any other person therein or with any other person's use thereof nor throw or push, or attempt to throw or push any person into the swimming pool or throw any matter or thing to the annoyance of any person using the Centre.

(c) No person or group of persons shall play any ball games or take any action whatsoever which shall in any way limit the enjoyment of the users of the swimming pool except that this by-law shall not apply to the playing of any games or aquatic sports organised and conducted in the swimming pool section by any Club, association or organisation or other person at such time and in such manner as shall be approved by the Council.

(d) No person liable for the control of an animal shall cause or permit such animal to enter or remain in or about the Centre.

17. No person shall:—

- (a) Obstruct the Centre Director or Attendant in carrying out his duties.
- (b) Enter or depart from any part of the Centre except by means of the respective entrances or exits set apart for that purpose.
- (c) Dress or undress or remove any part of his or her bathing costume except in a dressing room enclosure provided for that purpose.
- (d) Appear in public unless properly attired in a costume of such nature as to preserve public decency and to cover the body so as to prevent indecent exposure of the person.
- (e) Enter or be in the Centre while in an intoxicated condition induced by liquor.
- (f) Take into the swimming pool section or have in his possession therein, any intoxicating liquor.
- (g) Use any soap in any part of the swimming pool section.
- (h) Climb up or upon any roof, fence, wall or partition of the Centre.
- (i) In any part of the Centre behave in an unseemly, improper, disorderly, riotous or indecent manner; swear or use any indecent, obscene, offensive or abusive language or misconduct himself or herself.
- (j) Deposit any filth or rubbish in any part of the Centre except in places set aside for that purpose.

- (k) Smoke, consume foodstuffs or drinks in any specific area in which smoking or consumption is prohibited by notice.
- (l) Wastefully use the water or leave any taps dripping in the dressing rooms or elsewhere in the Centre.
- (m) Spit or expectorate in the swimming pool or in any part of the Centre or in any way commit any nuisance on or in any part of such Centre.
- (n) Use any substance or preparation whereby the water of the swimming pool may become discoloured or rendered turbid or otherwise unfit for the proper use of bathers.
- (o) Foul or pollute water in any shower, bath or in the swimming pool, or soil, damage, destroy, use improperly, disfigure or write in or upon any part of the Centre or any furniture or other article of equipment therein.
- (p) Damage, improperly use or interfere with any tap, valve, locker or other fitting or appliance in or about the Centre or bring or deposit any filth or rubbish onto or in the Centre.
- (q) Erect decoration for any function unless attached to the fittings provided in such a manner that damage does/not result.
- (r) Whilst suffering from any contagious or cutaneous disease, or whilst in an unclean condition, enter or use or attempt to enter or use the swimming pool or the Centre or any part thereof.
- (s) Soil or defile or damage any towel or bathing costume.
- (t) Break, damage or destroy any life saving or other equipment or any locker key or any property of the Council. Any person who does permits or suffers to be done any damage in contravention of the by-laws 17 (o), 17 (p) or 17 (q) above shall be liable to pay the cost of all such damages in addition to any penalty imposed by these by-laws.

18. Neither the Council nor the Centre Director or Attendant or officers or employees of the Council shall in any way be responsible for any articles or money lost by or stolen from any person whilst in the Centre or for any articles damaged or destroyed whilst in or about the Centre.

19. A person who infringes any of the provisions of these by-laws or shall attempt any breach thereof may be summarily removed from the Centre or any part thereof by the Centre Director or an Attendant, and if committing a breach of these by-laws, may be arrested by the Centre Director or an Attendant and given into the custody of a police officer.

20. (a) The Centre Director or an Attendant may refuse to admit to the Centre any person who shall have been convicted of a breach of any of the provisions of these by-laws until such time as the Council may decide that such person shall be admitted.

(b) The Council may issue a written direction to the Centre Director that any person named in such direction shall not be admitted to the Centre and whilst such direction remains in force the Centre Director or an Attendant shall not admit such person to the Centre or permit him to be therein and such person shall not, with the knowledge that such direction is in force, enter or attempt to enter the Centre.

21. Any person who shall commit a breach of these by-laws shall be liable to:—

- (a) a maximum penalty of \$100.
- (b) a maximum daily penalty during the breach of \$10 per day.

Dated the 6th day of August, 1981.

The Common Seal of the Shire of Esperance was hereunto affixed by authority of a resolution of the Council in the presence of—

[L.S.]

M. J. ANDRE,  
President.

E. L. CHOWN,  
Shire Clerk.

Recommended—

JUNE CRAIG,  
Minister for Local Government.

Approved by His Excellency the Governor in Executive Council this 26th day of August, 1981.

J. E. A. PRITCHARD,  
Acting Clerk of the Council.

## LOCAL GOVERNMENT ACT 1960-1981.

The Municipality of the Shire of Greenough.

## By-Laws Relating to Signs, Hoardings and Billposting.

IN pursuance of the powers conferred upon it by the abovementioned Act, the Council of the abovementioned Municipality hereby records having resolved on 26 June 1981, to make and submit for confirmation by the Governor, the following By-laws:

The By-laws of the Shire of Greenough Relating to Signs, Hoardings and Billposting published in the *Government Gazette* on 13 July 1967 and amended in the *Government Gazette* on 10 April 1981, are hereby amended by:—

## 1. Amend By-law 2 by—

(i) inserting after the interpretation of "residential area" the following:

"rural producer sign" means a sign advertising for sale the produce grown on a farm;

(ii) inserting after the interpretation of "sale sign" the following:

"sandwich board sign" means a sign consisting of two sign boards attached to each other end to end by hinges or other means.

2. Amend By-law 3 (2) (c) by deleting the passage "occupation." in line 3 and substituting the passage "occupation; and", and by adding a new sub-by-law designated:

"(d) a sign erected by the Council of the Shire of Greenough on land under the care, control and management of the Council."

## 3. Add after By-law 20 the following By-laws:

## "Rural Producer Signs.

20A. A rural producer sign shall—

- (a) not indicate or display any matter otherwise than for the purpose of advertising the sale of produce grown on the land on which the sign is erected;
- (b) be erected within the boundaries of the land on which the produce offered for sale was grown;
- (c) not exceed 0.6 square metres in area; and
- (d) not be of a height of more than 2 metres from the natural ground level.

## Sandwich Board Signs.

20B. 1. A sandwich board sign shall—

- (a) not exceed 900 mm in height;
- (b) not exceed 0.8 square metres in area on each side;
- (c) not indicate or display any matter other than the name of the owner or occupier of the premises to which it relates and the nature of the business carried on therein;
- (d) contain the word "open"; and
- (e) not contain any letter of a size less than 120 mm.

2. A person shall not erect a sandwich board sign in any position other than adjacent to the building to which the sign relates.

3. A person shall not erect more than one sandwich board sign in relation to the one building.

4. A person who erects a sandwich board sign shall remove it at the close of business each day and shall not erect it again until the commencement of business on the following or a subsequent day."

## 4. Amend By-law 37 by adding after the expression "\$100" in line 2 the following:

"and where the offence is one of a continuing nature, a daily penalty not exceeding \$10."

\_\_\_\_\_

Dated this 9th day of July, 1981.

The Common Seal of the Shire of Greenough was  
hereunto affixed in the presence of—

[L.S.]

\_\_\_\_\_

R. W. MASLEN,  
President.

R. G. BONE,  
Shire Clerk.

\_\_\_\_\_

Recommended—

\_\_\_\_\_

JUNE CRAIG,  
Minister for Local Government.

Approved by His Excellency the Governor in Executive Council this 26th day of August, 1981.

\_\_\_\_\_

J. E. A. PRITCHARD,  
Acting Clerk of the Council.

## DOG ACT 1976-1977.

Shire of Tammin.  
By-laws Relating to Dogs.

IN pursuance of the powers conferred upon it by the abovementioned Act and of all other powers enabling it, the Council of the abovementioned Municipality hereby records having resolved on 16 January 1981, to make and submit for confirmation by the Governor the following by-laws relating to Dogs.

## Part I—Preliminary.

1. In these by-laws unless the context otherwise requires:—

“Act” means the Dog Act 1976-1977.

“Council” means the Council of the Shire of Tammin.

“Form” means a form contained in the Second Schedule.

“Schedule” means a schedule to these by-laws.

Expressions used in these by-laws have the meanings given to them by the Act.

2. The by-laws of the Shire of Tammin relating to dogs published in the *Government Gazette* of 28 February 1975, are hereby revoked.

3. Part III of these by-laws—Keeping of Dogs—is applicable only to the Townsite of Tammin.

## Part II—Impounding of Dogs.

4. The poundkeeper shall be in attendance at the pound for the release of dogs at such time and on such days of the week as shall from time to time be determined by the Council.

5. If the owner, or person apparently acting on behalf of the owner, of a dog seized or impounded shall claim such dog then upon payment of the fees specified in the First Schedule hereto the dog shall be released to such person.

6. If the Council shall destroy a dog at the request of its owner, whether such dog shall have been seized or impounded or not, the owner shall pay to the Council the fee specified in the First Schedule hereto.

## Part III—Keeping of Dogs.

7. The occupier of premises situated within the Townsite of Tammin shall not, unless the premises are licensed as an approved kennel establishment under Section 27 of the Act, or have been granted exemption pursuant to Section 26 (3) of the Act, keep or permit to be kept on those premises more than two dogs over the age of three months and the young of those dogs under that age.

8. An application for a licence to keep an approved kennel establishment shall be in writing and shall be in or substantially in the form of Form 1 of the Second Schedule.

9. A licence to keep an approved kennel establishment shall be in or substantially in the form of Form 2 of the Second Schedule.

10. The fees payable for both the issue and renewal of a licence to keep an approved kennel establishment are those specified in the First Schedule.

11. The occupier of any premises which have been licensed by the Council as an approved kennel establishment shall provide kennels and yards sited and maintained in accordance with specifications of a standard not less than the following:—

- (a) Each kennel shall have a yard appurtenant thereto.
- (b) Each kennel and each yard and every part thereof shall not be at any less distance than 10 metres from the boundaries of the land in the occupation of the occupier.
- (c) Each kennel and each yard and every part thereof shall not be at any less distance than 24 metres from any road or street constituting the front boundary or not less than 10 metres from any road or street constituting a side boundary.
- (d) Each kennel and each yard and every part thereof shall not be any less distance than 20 metres from any dwelling, shop, church, school room, hall or factory.
- (e) The walls shall be constructed of concrete, brick, stone, wood, asbestos, ceelite or galvanised iron.
- (f) The roof shall be constructed of impervious material or other material approved by the Council.
- (g) All external surfaces of galvanised iron, wood or asbestos material shall be painted and kept painted with good quality paint.
- (h) The lowest internal height shall be at least 1.8 metres from the floor.
- (i) Each yard shall be securely fenced and kept securely fenced with a fence not less than 1.8 metres in height constructed of galvanised iron, wood, galvanised link mesh, netting or other material approved by the Council.
- (j) All gates shall be provided with proper catches or means of fastening.
- (k) The upper surfaces of the floor of each kennel shall be set at least 100 mm above the surface of the surrounding ground and shall be constructed of granolithic cement finished to a smooth surface and have a fall of not less than 1 in 100; the entire yard shall be surrounded by a drain which shall be properly laid, ventilated and trapped; all floor washings shall pass through the drain and shall be disposed for in accordance with the health requirements of the Council.



## Form 2.

Shire of Tammin.

## Licence to Keep an Approved Kennel Establishment.

..... is/are the holder(s)  
of a licence to keep an approved kennel establishment at .....  
..... for .....  
dogs of ..... breed(s).  
This Licence has effect for a period of 12 months from the date hereof.  
Dated the ..... day of ..... 19.....

.....  
Shire Clerk.

Dated this 22nd day of July, 1981.

The Common Seal of the Shire of Tammin is  
hereunto affixed in the presence of—

[L.S.]

A. E. ROGERS,  
President.  
R. G. TONKIN,  
Shire Clerk.

Recommended—

JUNE CRAIG,  
Minister for Local Government.

Approved by His Excellency the Governor in Executive Council this 26th day of  
August, 1981.

J. E. A. PRITCHARD,  
Acting Clerk of the Council.

## LOCAL GOVERNMENT ACT 1960-1981.

The Municipality of the Shire of Waroona.

## By-laws Relating to Control and Management of Halls.

IN pursuance of the powers conferred upon it by the abovementioned Act and of all other powers enabling it, the Council of the abovementioned Municipality hereby records having resolved on 20 November 1980, to make and submit for confirmation by the Governor the following By-laws:—

1. The existing By-laws relating to the Control and Management of Halls which were published in the *Government Gazette* on 14 March 1980 are hereby revoked.
2. In these By-laws:—
  - “Hall” means any hall or halls or any part or portion thereof which is or are on land vested in or under the care control or management of Council.
  - “Council” means the Council of the Municipality of the Shire of Waroona.
  - “Hall Committee” means a committee of management appointed by the Council to manage a hall.
  - “Clerk” means the Shire Clerk of the Shire of Waroona or any person from time to time acting in his place.
3. Council may appoint a hall committee to manage and control any hall within the Shire.
4. Application for the hire of a hall or any portion thereof or equipment or property under the control of the Council shall be made to the respective hall committee not less than 24 hours before the hour at which hiring is desired. Where there is no hall committee in respect of a hall, application shall be made to Council.
5. Council or a hall committee may at any time cancel the hiring of a hall or any part thereof.
6. In the event of two or more applications being received for the hire of any hall for the same time and date Council or the hall committee may without considering priority of application determine to which applicant the hall hiring shall be granted.
7. Subject to the provisions of the Liquor Act no spiritous liquors wine ale or spirits shall be brought into or consumed at any hall except when permitted in writing by Council or the hall committee.
8. No plant furniture fittings and other contents of any kind shall be hired loaned or removed from a hall without permission in writing from Council or a hall committee.
9. No person shall erect any internal or external decoration or place cause or allow to be placed any nails or screws in any part of a hall except with prior permission in writing of Council or the hall committee which permission shall be conditional upon the removal of all such decoration nails and screws by 10.00 a.m. on the day following the hiring.
10. No person shall enter or remain upon or be permitted to enter or remain upon a hall or part thereof while intoxicated.



11. Any person who uses any profane or improper language in a hall or who damages or marks or defaces or permits to be damaged marked or defaced a hall commits an offence. Any damage mark or defacement may be repaired by Council or the hall committee and the cost thereof recovered by Council from the hirer or any other person responsible in any Court of competent jurisdiction.

12. No offensive impersonations or representations of living persons or anything deemed likely to produce disturbances riot or breaches of the peace shall be permitted within a hall.

13. The hirer of a hall or any part thereof shall keep and maintain good order and behaviour and shall be personally responsible for compliance with these by-laws.

14. Food shall not be served or consumed in a hall without the permission in writing of Council or the hall committee being first obtained.

15. Officers of Council and other persons, authorised by Council or the hall committee may enter a hall or part thereof at any time.

16. Photographs shall not be taken in a hall without the permission of the hirer. Films of above 16 mm in size shall not be shown in a hall without the permission in writing of Council or the hall committee being first obtained.

17. The hirer of a hall shall indemnify Council and the hall committee from any claim for breach of copyright arising out of music played by the hirer or other persons within a hall during that hiring.

18. Council or a hall committee shall not accept bookings of a hall more than 12 months in advance.

19. Any person who does permits or suffers an act or matter or thing contrary to any of the By-laws or commits or permits any breach or neglects compliance therewith commits an offence against these By-laws and shall be liable to a penalty not exceeding \$200.00 for every such offence.

Dated this 4th day of August, 1981.

The Common Seal of the Municipality was hereto  
affixed in the presence of—

[L.S.]

R. J. CARATTI,  
President.

R. T. GOLDING,  
Shire Clerk.

Recommended—

JUNE CRAIG,  
Minister for Local Government.

Approved by His Excellency the Governor in Executive Council this 26th day of August, 1981.

J. E. A. PRITCHARD,  
Acting Clerk of the Council.

#### FACTORIES AND SHOPS ACT 1963-1978.

#### SHOPS (EXEMPTED GOODS) AMENDMENT REGULATIONS 1981.

MADE by His Excellency the Governor in Executive Council.

Citation. 1. These regulations may be cited as the Shops (Exempted Goods) Amendment Regulations 1981.

Reg. 3 amended. 2. Regulation 3 of the Shops (Exempted Goods) Regulations 1974\*, as amended, is amended—

(a) in paragraph (b) by deleting "bottled and";

(b) in paragraph (d)—

(i) by deleting "Cooked provisions" and substituting the following—

" small goods " ;

(ii) by inserting after "prepared breakfast cereals," the following—

" baked beans, spaghetti, " ;

(iii) by inserting after "cooking oils" the following—

" , fats " .

(c) in paragraph (i) by inserting after "flower pots" the following—

" , railway sleepers, rocks, spades, rakes, irrigation fittings " ;  
and

(d) in paragraph (o) by inserting after "walking sticks," the following—

" rain water tanks, " .

By His Excellency's Command,

J. E. A. PRITCHARD,  
Acting Clerk of the Council.

\* Published in the *Government Gazette* 22 February 1974 at p. 604.

## HIRE PURCHASE ACT 1959-1980.

HIRE PURCHASE (CREDIT PROVIDERS LICENSING) AMENDMENT  
REGULATIONS 1981.

MADE by His Excellency the Governor in Executive Council.

Citation. 1. These regulations may be cited as the Hire Purchase (Credit Providers Licensing) Amendment Regulations 1981.

Commencement. 2. These regulations shall come into operation on 1 October 1981.

Principal regulations. 3. In these regulations, the Hire Purchase (Credit Providers Licensing) Regulations 1975\*, as amended, are referred to as the principal regulations.

First Schedule amended. 4. The First Schedule to the principal regulations is amended—  
(a) in item 1, by deleting subparagraphs (i) and (ii) of paragraph (a) and substituting the following subparagraphs—

“ (i) Fee calculated according to the total amounts financed by the applicant under hire purchase agreements in Western Australia during the period of twelve months immediately preceding the time of the making of the application.

Total amount financed:

	Fee payable
	\$
Did not exceed \$50 000	65
Exceeded \$50 000 but did not exceed \$100 000	125
Exceeded \$100 000 but did not exceed \$250 000	315
Exceeded \$250 000 but did not exceed \$500 000	625
Exceeded \$500 000 but did not exceed \$1 000 000	1 250
Exceeded \$1 000 000 but did not exceed \$5 000 000	2 500
Exceeded \$5 000 000 but did not exceed \$10 000 000	3 750
Exceeded \$10 000 000	6 250

(ii) Fee calculated according to the total number of hire purchase agreements financed by the applicant in Western Australia during the period of twelve months immediately preceding the time of the making of the application.

Total number of agreements Financed:

	Fee
	\$
Did not exceed 50 agreements	65
Exceeded 50 agreements but did not exceed 100 agreements	125
Exceeded 100 agreements but did not exceed 250 agreements	315
Exceeded 250 agreements but did not exceed 500 agreements	625
Exceeded 500 agreements but did not exceed 1 000 agreements	1 250
Exceeded 1 000 agreements but did not exceed 5 000 agreements	2 500
Exceeded 5 000 agreements but did not exceed 10 000 agreements	3 750
Exceeded 10 000 agreements	6 250

(b) in item 2—

(i) by deleting “100” in paragraph (a) and substituting the following—

“ 125 ” ; and

(ii) by deleting “50” in paragraph (b) and substituting the following—

“ 60 ” ;

(c) in item 3 by deleting “5” and substituting the following—

“ 10 ” ;

and

(d) in item 4 by deleting “5” and substituting the following—

“ 10 ” .

By His Excellency's Command,

J. E. A. PRITCHARD,  
Acting Clerk of the Council.

## PIG INDUSTRY COMPENSATION ACT 1942-1972.

## PIG INDUSTRY COMPENSATION AMENDMENT REGULATIONS 1981.

MADE by His Excellency the Governor in Executive Council.

- Citation. 1. These regulations may be cited as the Pig Industry Compensation Amendment Regulations 1981.
- Reg. 5 amended. 2. Regulation 5 of the Pig Industry Compensation Regulations 1943\*, as amended, is amended by deleting paragraphs (a), (b), (c) and (d) and substituting the following—
- “ (a) where the weight of the carcass does not exceed 50 kg—156 cents per kg;
- (b) where the weight of the carcass exceeds 50 kg but does not exceed 70 kg—156 cents per kg;
- (c) where the weight of the carcass exceeds 70 kg but does not exceed 90 kg—151 cents per kg;
- (d) where the weight of the carcass exceeds 90 kg—101 cents per kg. ”

By His Excellency's Command,  
J. E. A. PRITCHARD,  
Acting Clerk of the Council.

\* Published in the *Government Gazette* on 14 May 1943 at pp. 479-481.

## STOCK DISEASES (REGULATIONS) ACT 1968-1978.

## ENZOOTIC DISEASES REGULATIONS NOTICE 1981.

MADE by the Minister under regulation 56.

- Citation. 1. This Notice may be cited as the Enzootic Diseases Regulations Notice 1981.
- Cancellation. 2. The declaration published in the *Government Gazette* on 11 February 1977 designating the Northern Pastoral Tuberculosis Control Area is cancelled.
- Commencement. 3. This notice shall take effect on and from the date of publication in the *Government Gazette*.

R. C. OLD,  
Minister for Agriculture.

## DAIRY INDUSTRY ACT 1973-1980.

## DAIRY INDUSTRY AMENDMENT REGULATIONS 1981.

MADE by His Excellency the Governor in Executive Council.

- Citation. 1. These regulations may be cited as the Dairy Industry Amendment Regulations 1981.
- Commencement. 2. (1) These regulations, other than regulations 1, 2, 3, 9, 10 (d), 11 and 12, shall come into operation on and from 1 October 1981.
- (2) Regulations 1, 2, 3, 9, 10 (d), 11 and 12 shall come into operation on and from the date these regulations are published in the *Government Gazette*.
- Principal regulations. 3. In these regulations the Dairy Industry Regulations 1977\*, as amended, are referred to as the principal regulations.
- Reg. 9 amended. 4. Regulation 9 of the principal regulations is amended by repealing subregulation (3) and substituting the following subregulation—
- “ (3) For the purposes of the definition of “vendor” in section 5 of the Act a person who by himself or his employees distributes and sells milk to consumers from a vehicle shall be a person of a prescribed class. ”
- Reg. 9A inserted. 5. After regulation 9 of the principal regulations the following regulation is inserted—
- “ 9A. (1) For the purposes of Section 52 (4) of the Act the following licences are prescribed—
- (a) milk distributor licence; and
- (b) milk wholesaler licence.
- (2) A person shall not, otherwise than as a carrier of milk or dairy produce, supply or distribute milk or dairy produce to any person who is not a consumer except under the authority of a milk distributor licence in Form DB for each district concerned, issued by the Authority permitting him to do so.
- (3) A person shall not supply milk or dairy produce—
- (a) to a carrier of milk or dairy produce; or
- (b) to any person other than the holder of a milk vendor licence or a milk distributor licence,
- except under the authority of a milk wholesaler licence in Form DD for each district in which the milk is to be retailed, issued by the Authority permitting him to do so. ”

\* Published in *Government Gazette* 31 August 1977 at pp. 3072-3121.

- Reg. 14 substituted. 6. Regulation 14 of the principal regulations is repealed and the following regulation is substituted—  
 “ 14. Every milk vendor and every milk distributor shall keep records indicating—  
 (a) the quantity of milk purchased and received by him on every day;  
 (b) the quantity of milk sold, supplied or distributed by him on every day and the dairy area and district in which such sale, supply or distribution is made; and  
 (c) the names and addresses of the persons from whom he acquired the milk so sold, supplied or distributed. ” .
- Reg. 22 amended. 7. Regulation 22 of the principal regulations is amended—  
 (a) in subregulation (5) by inserting after “licensed vendor” in paragraph (c) the following—  
 “ , licensed distributor, licensed wholesaler ” ; and  
 (b) in subregulation (7) by deleting “or licensed vendor” in paragraph (b) and substituting the following—  
 “ , licensed vendor, licensed distributor or licensed wholesaler ” .
- Reg. 131 amended. 8. Regulation 131 of the principal regulations is amended in subregulation (2) by inserting after “vendor” the following—  
 “ , distributor ” .
- Reg. 133 amended. 9. Regulation 133 of the principal regulations is amended in subsection (3) by deleting “while the vehicle is used for transporting milk and dairy produce except while that door or opening is being used during delivery of milk and dairy produce.” and substituting the following—  
 “ whenever the vehicle is in motion. ” .
- Reg. 136 amended. 10. Regulation 136 of the principal regulations is amended—  
 (a) in subregulation (5), by deleting “A person, other than a milk vendor (vehicle) who is engaged in the delivery of milk to shops or households, shall not” and substituting the following—  
 “ Subject to subregulation (4) of this regulation a person, other than a milk vendor or milk distributor who is engaged in the delivery or carriage of milk, shall not ” ;  
 (b) in subregulation (6), by deleting “milk vendor (vehicle)” and substituting the following—  
 “ milk vendor licence or milk distributor ” ;  
 (c) in subregulation (7), by deleting “(vehicle)” and substituting the following—  
 “ or milk distributor ” ;  
 (d) in subregulation (8)—  
 (i) by deleting “(vehicle)”; and  
 (ii) by deleting paragraph (a) and substituting the following paragraph—  
 “ (a) shall provide a delivery service on not less than 5 days of the week on the days specified by the Authority. ” ;  
 (e) by inserting after subregulation (8) the following subregulation—  
 “ (8a) Every account rendered to a customer by the holder of a milk vendor licence or a milk distributor licence or a person acting on his behalf, shall show the name and address of the licence holder thereon. ” ;  
 (f) in subregulation (9)—  
 (i) by deleting “vending (vehicle) licence” and substituting the following—  
 “ vendor licence or milk distributor licence ” ; and  
 (ii) by deleting “shops and customers” and substituting the following—  
 “ persons ” ;  
 (g) in subregulation (10)—  
 (i) by deleting “shops and customers to which a vendor may deliver milk within an area or district, the vendor” and substituting the following—  
 “ persons to whom a milk vendor or milk distributor may deliver milk within an area or district, the vendor or distributor ” ; and  
 (ii) by deleting “, shop or customer”; and  
 (h) in subregulation (11)—  
 (i) by deleting “(vehicle)” and substituting the following—  
 “ licence or milk distributor ” ; and  
 (ii) by inserting after “sold” the following—  
 “ or distributed ” .

- Reg. 154 amended. 11. Regulation 154 of the principal regulations is amended in sub-regulation (2) by deleting "this Act" and substituting the following—  
" the Act " .
- Reg. 156 amended. 12. Regulation 156 of the principal regulations is amended by inserting after subregulation (2) the following subregulation—  
" (3) Where an offence is committed against these regulations by any person who is the servant or agent of the holder of a milk vendor licence or a milk distributor licence the milk vendor or milk distributor shall be liable under these regulations in the same manner and to the same extent as if he had personally committed the offence unless he proves that the offence was committed without his knowledge and that he exercised all due diligence to prevent the commission of the offence. " .
- First Schedule amended. 13. The First Schedule to the principal regulations is amended—  
(a) by deleting that part of the Schedule which commences with "Milk or dairy produce vendor:" and ends with "... D Nil" and substituting the following—  
" Milk or dairy produce vendor:  
Application form as milk vendor .... C Nil  
Licence as milk vendor .. ... D Nil  
Milk or dairy produce distributor:  
Application form as milk distributor .... DA Nil  
Licence as milk distributor .... DB Nil  
Milk or dairy produce wholesaler:  
Application form as milk wholesaler .... DC Nil  
Licence as milk wholesaler .... DD Nil  
" ;  
(b) by deleting that part of the Schedule which commences with "Quota:" and ends with "... M Nil" and substituting the following—  
" Quota:  
Invitation to apply for and application for the grant of, a quota (market use) .... M Nil  
Invitation to apply for and application for the grant of, a quota (products use) .. ... MA Nil  
" ;  
(c) by deleting Forms C and D and substituting the following forms—

" DAIRY INDUSTRY REGULATIONS 1977.

Form C.

DAIRY INDUSTRY ACT 1973.

APPLICATION FOR A LICENCE AS A MILK VENDOR.

O	
F	
F	
I	
C	USE
I	
A	Lic. No.:
L	

TO: The Dairy Industry Authority of Western Australia, 217/219 Stirling Highway, (P.O. Box 75), CLAREMONT. W.A. 6010.

Names in full of Applicant(s)	Surname(s)	First Name(s) State Mr., Mrs. or Miss

(PLEASE USE BLOCK LETTERS)

Business Name .....  
 (If Proprietary Co., Society or Co-op.) .....  
 Postal Address .....  
 Telephone No.: .....  
 Address of milk store (if any) .....  
 District for which Licence is required .....

(A separate application is required for each district)

N.B. If the licensee is to be restricted to cover sale to certain specified customers only, a list of their names and addresses must be attached.

Supplies will be purchased from .....

	MILK	CREAM
Average Daily Sales:		
For above Districts ONLY Sold wholesale .....	litres .....	litres
Sold retail .....	litres .....	litres

Names and Addresses of persons acting on behalf of the licensee (other than as a servant)—

.....

.....

.....

.....

.....

.....

.....

.....

Total number of vehicles used in business .....

I/WE hereby declare that the foregoing particulars are true and correct in every detail and apply for a licence authorising me/us to sell milk and/or cream in the district mentioned above.

Signature(s) of Applicant(s) .....

Date ..... (if applicant is a company, state capacity of persons signing)

NO FEE IS REQUIRED WITH THIS APPLICATION

DAIRY INDUSTRY REGULATIONS 1977.

Form D.

DAIRY INDUSTRY ACT 1973. (No. in duplicate)

MILK VENDOR LICENCE,

- (1) Name(s) of Milk Vendor: .....
- .....
- (2) Postal Address: .....
- (3) Supplies to be purchased from: .....
- (4) This licence is valid up to and including June 30, 19....., unless previously cancelled, suspended or surrendered.

THIS IS TO CERTIFY that each of the persons named above is licensed by the Dairy Industry Authority of Western Australia under the provisions of sections 52 to 60 of the Dairy Industry Act 1973 and is, subject to any conditions endorsed hereon, authorised to carry on the business of a milk vendor in the district of .....

Other Conditions

Dated this day of 19.....

The Dairy Industry Authority of Western Australia  
Manager

Names and addresses of persons acting on behalf of the licensee (other than as a servant)—

.....

.....

.....

.....

.....

.....

.....

.....

This licence is NOT TRANSFERABLE without the consent in writing of the Authority and may be cancelled or suspended if the holder fails to comply with certain requirements of the Dairy Industry Act 1973, and the regulations thereunder.



Other Conditions

Dated this day of 19..... The Dairy Industry Authority of Western Australia Manager

Names and addresses of persons acting on behalf of licensee (other than as a servant)---

.....

This licence is NOT TRANSFERABLE without the consent in writing of the Authority and may be cancelled or suspended if the holder fails to comply with certain requirements of the Dairy Industry Act 1973, and the regulations thereunder.

DAIRY INDUSTRY REGULATIONS 1977.

Form DC.

DAIRY INDUSTRY ACT 1973.

APPLICATION FOR A LICENCE AS A MILK WHOLESALER.

O F F I C I A L

USE

Lic. No.:

TO: The Dairy Industry Authority of Western Australia, 217/219 Stirling Highway, (P.O. Box 75), CLAREMONT. W.A. 6010.

Table with 3 columns: Names in full of Applicant(s), Surname(s), First Name(s) State Mr., Mrs. or Miss

(PLEASE USE BLOCK LETTERS)

Business Name .....

(If Proprietary Co., Society or Co-op.) .....

Postal Address .....

Telephone No.: .....

Name and Address of Carrier .....

District for which Licence is required .....

(A separate application is required for each district)

N.B. If the licensee is to be restricted to cover sale to certain specified customers only, a list of their names and addresses must be attached.

Average Daily Sales: MILK CREAM For above Districts ONLY Sold wholesale .....litres .....litres

I/WE hereby declare that the foregoing particulars are true and correct in every detail and apply for a licence authorising me/us to supply milk and/or cream to be carried to the district mentioned above.

Signature(s) of Applicant(s) .....

Date ..... (if applicant is a company, state capacity of person signing)

NO FEE IS REQUIRED WITH THIS APPLICATION



DAIRY INDUSTRY REGULATIONS 1977.

Form DD.

DAIRY INDUSTRY ACT 1973.

(No. in duplicate)

MILK WHOLESALER LICENCE.

- (1) Name(s) of Milk Wholesaler: .....
- (2) Postal Address: .....
- (3) This licence is valid up to and including June 30, 19....., unless previously cancelled, suspended or surrendered.

THIS IS TO CERTIFY that each of the persons named above is licensed by the Dairy Industry Authority of Western Australia under the provisions of sections 52 to 60 of the Dairy Industry Act 1973 and is, subject to any conditions endorsed hereon, authorised to carry on the business of a milk wholesaler for the district of .....

Other Conditions

Dated this  
day of  
19.....  
The Dairy Industry  
Authority of  
Western Australia  
Manager

This licence is NOT TRANSFERABLE without the consent in writing of the Authority and may be cancelled or suspended if the holder fails to comply with certain requirements of the Dairy Industry Act 1973, and the regulations thereunder; and

- (d) by deleting Form M and substituting the following forms—

DAIRY INDUSTRY REGULATIONS 1977.

Form M.

DAIRY INDUSTRY ACT 1973.

INVITATION TO APPLY FOR AND APPLICATION FOR THE GRANT OF, A QUOTA (MARKET USE).

To: (Addressee) (Date)

Dear Sir/Madam,

In accordance with the provisions of sections 26 (1) and 28 (1) of the Dairy Industry Act 1973 you are invited to apply to the Authority for the granting of a quota for the supply of ..... litres of milk for market use from registered dairy produce premises No. .... situated at ..... to be delivered during the quota year commencing on ..... and ending on ..... both dates inclusive.

If you wish to apply for a quota, the application form below must be completed and returned to the Authority not later than

Yours faithfully,  
Manager.

(Please detach here)

TO: The Dairy Industry Authority of Western Australia,  
P.O. Box 75, Claremont, W.A., 6010. Telephone: 384 4111.

I/WE .....  
(if Proprietary Co., Society or Co-op., state registered name)

PLEASE USE BLOCK LETTERS

Hereby apply for the granting of a quota by the Authority in accordance with sections 26 (1) and 28 (1) of the Dairy Industry Act 1973 for the supply of ..... litres of milk for market use from registered dairy produce premises No. .... situated at ..... to be delivered during the quota year commencing on ..... and ending on ..... both dates inclusive.

Date ..... Signed .....  
(if applicant is a company, show capacity of person signing.)

Address: .....



STATE TENDER BOARD OF WESTERN AUSTRALIA—continued.  
Tenders for Government Supplies—continued

Date of Advertising	Schedule No.	Supplies Required	Date of Closing
1981			1981
Sept. 4	641A/1981	Sewage Pumping Sets (8 Only)—M.W.B.	Sept. 17
Sept. 4	643A/1981	Wall Mounted Anaesthetic Units (Up to 9 Off) and Mobile Anaesthetic Machines (Up to 9 Off)—Sir Charles Gairdner Hospital	Sept. 17
Sept. 4	645A/1981	Road Motor Trucks (3/5 tonne—28 only: 7 tonne—6 only: 8 tonne—4 only)—Westrail	Sept. 17
Sept. 4	644A/1981	Electric Point Machines (15 only) and Searchlight Signals (40 only)—Westrail	Sept. 24
Sept. 4	646A/1981	Computer Equipment—Sir Charles Gairdner Hospital	Sept. 24
Sept. 4	647A/1981	Frozen Vegetables (1 year period)—Various Government Departments	Sept. 24
Sept. 4	648A/1981	Spray Bitumen Emulsion Enrichment Seal on North West Coastal Highway (Approx. 463 500 litres)—Pilbara Division—M.R.D.	Sept. 24
Aug. 14	602A/1981	Rail, 60 kg/metre (16 500 tonnes)—Westrail	Sept. 24
July 31	569A/1981	Road Motor Luxury Touring Coaches (4 or 8)—Westrail	Sept. 24
<i>Service Required</i>			
Aug. 21	617A/1981	Removal of Sludge at Subiaco Wastewater Treatment Plant (5, 7 or 10 year period)—M.W.B.	Sept. 10
Aug. 28	623A/1981	Mechanical Clearing of "Parkinsonia" West Kimberley—A.P.B.	Sept. 17
Aug. 28	625A/1981	Aeroplane Charter for Aerial Baiting Campaign Against Wild Dogs in the Pilbara Region (approx. 55 hours)—A.P.B.	Sept. 17
Aug. 28	630A/1981	Aeroplane Charter for Aerial Baiting Campaign against Wild Dogs in the Carnarvon Region (approx. 40 hours)—A.P.B.	Sept. 17

*For Sale by Tender*

Date of Advertising	Schedule No.	For Sale	Date of Closing
1981			1981
Aug. 21	609A/1981	1964 Modern Caravan (UQU 163) and 1969 Caravan (UQT 379) at Meekatharra	Sept. 10
Aug. 21	613A/1981	1977 Holden HZ Station Sedan (XQA 003) (recalled) at South Hedland	Sept. 10
Aug. 21	618A/1981	Stihl Chainsaws (2 only) at Mundaring Weir	Sept. 10
Aug. 21	619A/1981	1968 Toyota FJ40 Land Cruiser (UQE 928) (recalled) at Manjimup	Sept. 10
Aug. 28	622A/1981	1975 Ditch Witch V30 Trench Digger (PW 3295) with Howard Porter Tandem trailer (XQT 165) at East Perth	Sept. 10
Aug. 28	629A/1981	Nikasa Concrete Vibrator (1 only) and Wacker Concrete Vibrators (2 only) at East Perth	Sept. 10
Aug. 28	631A/1981	Howard Low Pressure Bitumen Heater (MRD 508) at East Perth	Sept. 10
Aug. 28	632A/1981	1972 Holman Air Compressor (PW 250) and 1972 C.P. Air Compressor (PW 259) at East Perth	Sept. 10
Aug. 28	620A/1981	1978 Toyota FJ45 Land Cruiser (XQJ 691) at Derby	Sept. 17
Sept. 4	636A/1981	Bonaire 8500/2 Evaporative Air Conditioning Plant at East Perth	Sept. 17
Sept. 4	637A/1981	Moto Guzzi 850cc Motor Cycle (RTA 841) (Accident Damaged) at East Perth	Sept. 17
Sept. 4	638A/1981	1976 Holden HJ One Tonne Utility (UQS 970) and 1960 Bedford 5 Tonne Tip Truck (UQE 741) at Gnangara	Sept. 17
Sept. 4	633A/1981	Falcon Sedan (1 only): Holden Torana (1 only): Holden Utility (1 only): Toyota 4 x 4 (5 only) and Holden One Tonner (1 only) at Manjimup	Sept. 24
Sept. 4	634A/1981	1965 Bedford 5/7 Ton Truck (XQD 161): 1963 Caterpillar D4C Bulldozer (UQE 544): 1969 Michigan 45A Shovel Loader (UQC 569) at Ludlow	Sept. 24
Sept. 4	635A/1981	Bedford Trucks (3 only): Bedford Tipper (1 only) and Allis Chalmers Grader (1 only) at Manjimup	Sept. 24
Sept. 4	639A/1981	1970 Toyota S.W.B. 4 x 4 (UQF 832) at Ludlow	Sept. 24
Sept. 4	640A/1981	Holden HX One Tonne (UQY 955) (Re-called) at Carnarvon	Sept. 24
Sept. 4	642A/1981	One complete set of trawling gear for a twin rigged Prawn Trawler at Carnarvon	Sept. 24
Sept. 4	649A/1981	Holman Compressor (UQT 773) and Ancillary Equipment at Port Hedland	Sept. 24

Tenders addressed to the Chairman, State Tender Board, 74 Murray Street, Perth, will be received for the abovementioned schedules until 10 a.m. on the dates of closing.

Tenders must be properly endorsed on envelopes otherwise they are liable to rejection.

Tender forms and full particulars may be obtained on application at the Tender Board Office, 74 Murray Street, Perth and at points of inspection.

No Tender necessarily accepted.

B. E. CORBOY,  
Chairman, Tender Board

STATE TENDER BOARD OF WESTERN AUSTRALIA—*continued.*

## ACCEPTANCE OF TENDERS

Schedule No.	Contractor	Particulars	Department Concerned	Rate
240A/81	Malcolm Thompson & Company	Supply and Delivery of variable speed Return Activate sludge pumping units	M.W.B. ....	\$138 354
288A/81	E. & M. J. Rosher P/L	Supply and Delivery of one (1) only mechanical road sweeper	M.R.D. ....	\$79 316
355A/81	Cairns Instrument Services	Supply and Delivery of Ultrasound Scanning Equipment	H. & A. S. ....	Details on application
365A/81	Various	Supply and Delivery of Jams, Condiments, Honey and Vinegar etc. (1 year period)	Various	Details on application
373A/81	Commonwealth Steel Co. Ltd.	Supply and Delivery of: Item 1: 192 only Wheels, Diesel Locomotive Rolled Steel to W.A.G.R. Drawing CME 16671 Item 2: 78 only Wheels, Diesel Locomotive Rolled Steel to W.A.G.R. Drawing CME No. 23686 Item 3: 50 only Wheels, Diesel Locomotive Rolled Steel to W.A.G.R. Drawing CME No. 52487	Westrail	\$694 each \$643 each \$743 each
417A/81	Various	Supply and Delivery of Limestone Sub Base Material, Crushed Limestone, Bitumen Stabilised Crushed Limestone Crushed Rock Base (Plastic and Non-Plastic) Crushed Blast Furnace Slag and Gravel	M.R.D. ....	Details on application
475A/81	The Shell Co. of Australia Ltd.	Supply of Lubricating Oil for "X" class Diesel Electric Locomotives as per Item 3 (Parts a, b, c, d)	Westrail	\$0.7192/litre
488A/81	D. E. Withers & Co.	Supply and Delivery of: Item 1: three (3) only Tractor three-point Linkage Mounting Hydraulically Driven Triple Gang Mowers Item 2: two (2) only Spare Cutting Units	P.W.D.	\$8 600 each \$1 550 each
<i>Services Required</i>				
292A/81	Ansett Wridgways	Service of the Packing/Unpacking and Transport of Furniture and effects of Teachers (until June 30, 1983)	Education	Details on application
293A/81	Ansett Wridgways	Service of the Packing/Unpacking and Transport of Furniture and Effects of Police Personnel	Police	Details on application
483A/81	Chapel Funerals	Service of the Removal of Bodies to the City Morgue at Sir Charles Gairdner Hospital (1 year period)	Police	Details on application
<i>For Sale</i>				
510A/81	C. D. Dodd	Purchase and Removal of: Item 1: Secondhand 1 x 200-litre drum of Pipe Joiners	P.W.D.	For the sum of \$33
	Houthuysen & Co.	Item 2: Secondhand Electrical Cable Cut Offs at East Perth		For the sum of \$101.50
513A/81	Cooper Motors	Purchase and Removal of: Item 1: Four (4) only secondhand Petrol Tanks (various sizes) Item 2: Four (4) only secondhand Petrol Tanks (various sizes) at East Perth	P.W.D.	For the sum of \$16.50 For the sum of \$15.50
536A/81	R. T. & P. A. Cole	Purchase and Removal of secondhand Lincoln Welding Plant (PW 137) at East Perth	P.W.D.	For the sum of \$375
549A/81	W. Bowater	Purchase and Removal of secondhand Broomwade Air Compressor (PW 258) at East Perth	P.W.D.	For the sum of \$157
553A/81	E. Ellison	Purchase and Removal of secondhand Toyota Dyna Table Top Truck (Reg. No. XQE 594) at Karratha	P.W.D.	For the sum of \$3 200
574A/81	D. M. Feldman	Purchase and Removal of secondhand Holden Station Sedan (Reg. No. UQZ 347) at Broome	P.W.D.	For the sum of \$1 751
575A/81	Champion Bay Board Riders	Purchase and Removal of secondhand Commer Bus (Reg. No. XQF 410) at Geraldton	P.W.D.	For the sum of \$390
577A/81	Soltoggio Bros	Purchase and Removal of secondhand Ford Truck (MRD 244) at Derby	M.R.D.	For the sum of \$1 166
578A/81	P. J. Gallaher	Purchase and Removal of secondhand Ford Falcon Sedan (RTA 022) at Karratha	R.T.A.	For the sum of \$2 275
580A/81	C. Doubleday	Purchase and Removal of: Item 1: Secondhand Moto Guzzi Motor Cycle, 1975 850 cc Model	R.T.A.	For the sum of \$400
	A. Sorokin	Item 2: Secondhand Moto Guzzi Motor Cycle, 1976 850 cc Model		For the sum of \$500

STATE TENDER BOARD OF WESTERN AUSTRALIA—*continued.*  
ACCEPTANCE OF TENDERS—*continued*

Schedule No.	Contractor	Particulars	Department Concerned	Rate
	A. F. Sanders	Item 3: Secondhand Moto Guzzi Motor Cycle, 1976 850 cc Model		For the sum of \$507.35
	S. R. Leighton	Item 4: Secondhand Moto Guzzi Motor Cycle, 1976 850 cc Model		For the sum of \$707
582A/81	J. Warren	Purchase and Removal of secondhand Dart Caravan (Reg. No. UQT 055) at Southern Cross	A.P.B.	For the sum of \$250
587A/81	Drew's Cleaning Service	Purchase and Removal of secondhand Holden Sedan (Reg. No. UQZ 332) at Wyndham	P.W.D.	For the sum of \$1 051.20
<i>Cancellation of Contract</i>				
215A/81	Mr. B. Crotty	Purchase and Removal of secondhand Holden 1 Tonne, HX (Reg. No. UQY 955) at Carnarvon	P.W.D.	
522A/81	A. H. Marshall	Purchase and Removal of Item 1: Secondhand Deutscher 360 Ride-on Mower at East Perth	P.W.D.	

MAIN ROADS DEPARTMENT

*Tenders*

Tenders are invited for the following projects.  
Tender documents are available from the Clerk in Charge, Orders Section, Main Roads Department, Waterloo Crescent, East Perth.

Tender No.	Description	Closing Date
33/81	Screened Laterite Gravel Kwinana Freeway	September 22 1981

D. R. WARNER,  
Secretary, Main Roads.

GOVERNMENT PRINTING OFFICE OF W.A.  
TENDERS FOR GOVERNMENT PRINTING

Tenders are invited for the supply of the undermentioned stores.  
Tenders close at Wembley, at 10.00 a.m. on 14/9/81.

Tender No.	Description	Size
CP 10290	200 books of 100 in duplicate	210 x 140 mm
CP 10304	2 000 single forms	205 x 253 mm
CP 10305	60 books of 50 in triplicate	297 x 210 mm
CP 10306	450 books of 50 in quadruplicate	103 x 156 mm
CP 10307	1 000 books of 10 in triplicate	263 x 280 mm

SPECIAL NOTE—STOCK:

Tenderers are requested to specify—

- Country of Origin.
- Brand or make of material.
- In this contract preference may be given to W.A. or other Australian made stocks in accordance with Government Policy.

ACCEPTANCE OF TENDERS

Tender No.	Particulars of Stores	Successful Tenderer	Amount
			\$
CP 10221	15 books of 100 in duplicate	Swan Print	72.00
CP 10222	1 200 single forms	George Percival	103.00
CP 10223	100 000 single forms	Swan Print	1 028.00
CP 10224	200 pads of 500 leaves	New Formula	495.00
CP 10225	200 books of 50 in quadruplicate	New Formula	561.00
CP 10226	60 pads of 50 in duplicate (fanapart sets)	George Percival	147.00
CP 10227	100 pads of 100 leaves	Excel Press	97.80
CP 10228	100 books of 50 in duplicate	George Percival	215.00

WILLIAM C. BROWN,  
Government Printer.

## APPOINTMENTS.

(Under section 6 of the Registration of Births, Deaths and Marriages Act 1961-1979.)

Registrar General's Office,  
Perth, 31 August 1981.

THE following appointments have been approved:—

R.G. No. 65/73.—First Class Constable Allan Ross Rice has been appointed as Assistant District Registrar of Births and Deaths for the Williams Registry District to maintain an office at Corrigin during the absence on leave of Senior Constable L. W. Morgan. This appointment dates from 17 August 1981 to 7 September 1981.

R.G. No. 33/73.—Mr. Stephen McKenzie Wilson has been appointed as District Registrar of Births, Deaths and Marriages for the Gascoyne Registry District to maintain an office at Carnarvon during the absence on leave of Mr. R. N. Johnson. This appointment dated from 27 July 1981 to 31 July 1981.

R.G. No. 48/68.—Mr. Philip Raymond Fisher has been appointed as Acting District Registrar of Births, Deaths and Marriages for the Perth Registry District to maintain an office at Perth during the absence on other duties of Mr. D. G. Stockins. This appointment dated from 31 August 1981 to 25 September 1981.

R.G. No. 393/73.—Sergeant Corny Neil Calameri has been appointed as Assistant District Registrar of Births, Deaths and Marriages for the Gascoyne Registry District to maintain an office at Exmouth during the absence on leave of Sergeant R. T. Harper. This appointment dates from 31 August 1981 to 10 October 1981.

R.G. No. 87/71.—Mr. James William Houlahan has been appointed as Assistant District Registrar of Births, Deaths and Marriages for the Blackwood Registry District to maintain an office at Manjimup during the absence on leave of Mr. R. J. Bremner. This appointment dates from 31 August 1981.

R.G. No. 114/71.—Mr. James Adair has been appointed as Assistant District Registrar of Births, Deaths and Marriages for the Katanning Registry District to maintain an office at Wagin during the absence on leave of Mr. D. F. Evans. This appointment dates from 1 September 1981 to 30 September 1981.

E. C. RIEBELING,  
Registrar General.

## MINING ACT 1904.

## Appointment.

Department of Mines,  
Perth, 26 August 1981.

THE Governor in Executive Council has been pleased to approve the following appointment:

Vincent John Roberts as Acting Mining Registrar, Meekatharra, to date from 29 June 1981.

D. R. KELLY,  
Under Secretary for Mines.

## ERRATUM.

## MINING ACT 1904.

THE notice appearing in the *Government Gazette* No. 64 dated 14 August 1981 under the heading Mining Act 1904 page 3369 under the heading "The under-mentioned applications for leases were approved conditionally:"

"Gold Mining Leases" is amended by deleting the numbers 10/1094 to 40/1097 and substituting therefore 40/1094 to 40/1097.

D. R. KELLY,  
Under Secretary for Mines.

## MINING ACT 1904.

(Regulation 180.)

Warden's Office, Broome,  
6 July 1981.

TAKE notice that it is the intention of the Warden of the Goldfield or Mineral Field mentioned hereunder, on the date mentioned, to issue out of the Warden's Court an order authorising the cancellation of registration of the undermentioned Mining Tenements for non payment of rent in accordance with Regulation 180 of the Mining Act 1904. An order may issue in the absence of the registered holder, but should he desire to object to such order he must, before the date mentioned, lodge at the Warden's Office an objection containing the grounds of such objection, and, on the date mentioned, the Warden will proceed to hear and determine the same, in accordance with the evidence then submitted.

J. A. HOWARD,  
Warden.

To be heard at the Warden's Court, Broome, on 24 September, 1981.

## WEST KIMBERLEY GOLDFIELD.

## Mineral Claims.

- 04/1654—Bromby, Lucy.  
04/2409—Johnston, Warwick Graham; Johnston, Beverley Nonia; Munster, Roy Thomas.  
04/2410—Johnston, Warwick Graham; Johnston, Beverley Nonia; Munster, Roy Thomas.  
04/2411—Johnston, Warwick Graham; Johnston, Beverley Nonia; Munster, Roy Thomas.  
04/2412—Johnston, Warwick Graham; Johnston, Beverley Nonia; Munster, Roy Thomas.  
04/2416—Johnston, Warwick Graham; Johnston, Beverley Nonia; Munster, Roy Thomas.  
04/2417—The Stellar Minerals Pty. Ltd.  
04/2418—The Stellar Minerals Pty. Ltd.  
04/2508—Jones, Judith Merle.  
04/2530—Ingram, Peter Anthony John; Ingram, Mary Margaret.  
04/2534—Ingram, Peter Anthony John; Ingram, Mary Margaret.  
04/2535—Ingram, Peter Anthony John; Ingram, Mary Margaret.  
04/2536—Ingram, Peter Anthony John; Ingram, Mary Margaret.  
04/2537—Ingram, Peter Anthony John; Ingram, Mary Margaret.  
04/2538—Ingram, Peter Anthony John; Ingram, Mary Margaret.  
04/2539—Ingram, Peter Anthony John; Ingram, Mary Margaret.  
04/2551—Ingram, Peter Anthony John; Ingram, Mary Margaret.  
04/2576—Magnet Metals Limited; Lennard Oil N.L.; Monarch Petroleum N.L.  
04/2577—Magnet Metals Limited; Lennard Oil N.L.; Monarch Petroleum N.L.  
04/2578—Barbara Investments Pty. Ltd.  
04/2579—Barbara Investments Pty. Ltd.  
04/2580—Barbara Investments Pty. Ltd.  
04/2581—Barbara Investments Pty. Ltd.  
04/2594—Barbara Investments Pty. Ltd.  
04/2595—Barbara Investments Pty. Ltd.  
04/2596—Barbara Investments Pty. Ltd. Monarch Petroleum N.L.  
04/2608—Magnet Metals Limited; Lennard Oil N.L.; Monarch Petroleum N.L.  
04/2609—Magnet Metals Limited; Lennard Oil N.L.; Monarch Petroleum N.L.  
04/2611—Magnet Metals Limited; Lennard Oil N.L.; Monarch Petroleum N.L.  
04/2612—Magnet Metals Limited; Lennard Oil N.L.; Monarch Petroleum N.L.  
04/2613—Magnet Metals Limited; Lennard Oil N.L.; Monarch Petroleum N.L.

- 04/2614—Magnet Metals Limited; Lennard Oil N.L.;  
Monarch Petroleum N.L.
- 04/2615—Magnet Metals Limited; Lennard Oil N.L.;  
Monarch Petroleum N.L.
- 04/2616—Magnet Metals Limited; Lennard Oil N.L.;  
Monarch Petroleum N.L.
- 04/2617—Magnet Metals Limited; Lennard Oil N.L.;  
Monarch Petroleum N.L.
- 04/2618—Magnet Metals Limited; Lennard Oil N.L.;  
Monarch Petroleum N.L.
- 04/2619—Magnet Metals Limited; Lennard Oil N.L.;  
Monarch Petroleum N.L.
- 04/2620—Magnet Metals Limited; Lennard Oil N.L.;  
Monarch Petroleum N.L.
- 04/2621—Magnet Metals Limited; Lennard Oil N.L.;  
Monarch Petroleum N.L.
- 04/2623—Magnet Metals Limited; Lennard Oil N.L.;  
Monarch Petroleum N.L.
- 04/2624—Magnet Metals Limited; Lennard Oil N.L.;  
Monarch Petroleum N.L.
- 04/2625—Magnet Metals Limited; Lennard Oil N.L.;  
Monarch Petroleum N.L.
- 04/2626—Magnet Metals Limited; Lennard Oil N.L.;  
Monarch Petroleum N.L.
- 04/2627—Magnet Metals Limited; Lennard Oil N.L.;  
Monarch Petroleum N.L.
- 04/2628—Magnet Metals Limited; Lennard Oil N.L.;  
Monarch Petroleum N.L.
- 04/2629—Magnet Metals Limited; Lennard Oil N.L.;  
Monarch Petroleum N.L.
- 04/2630—Magnet Metals Limited; Lennard Oil N.L.;  
Monarch Petroleum N.L.
- 04/2738—Magnet Metals Limited.
- 04/2739—Magnet Metals Limited.
- 04/2740—Magnet Metals Limited.
- 04/2741—Magnet Metals Limited.
- 04/2742—Magnet Metals Limited.
- 04/2743—Magnet Metals Limited.
- 04/2744—Magnet Metals Limited.
- 04/2745—Magnet Metals Limited.
- 04/2746—Magnet Metals Limited.
- 04/2747—Magnet Metals Limited.
- 04/2748—Magnet Metals Limited.
- 04/2749—Magnet Metals Limited.
- 04/2750—Magnet Metals Limited.
- 04/2751—Magnet Metals Limited.
- 04/2752—Magnet Metals Limited.
- 04/2753—Magnet Metals Limited.
- 04/2754—Magnet Metals Limited.
- 04/2755—Magnet Metals Limited.
- 04/2756—Magnet Metals Limited.
- 04/2860—A.S. Mining Ventures Pty. Ltd.
- 04/2865—Lennard River Diamonds Pty. Limited.
- 04/2866—Lennard River Diamonds Pty. Limited.
- 04/2867—Lennard River Diamonds Pty. Limited.
- 04/2868—Lennard River Diamonds Pty. Limited.
- 04/2954—Haoma Gold Mines N.L.; Haoma Prospecting  
Pty. Ltd.; North West Mining N.L.; Tari  
Pty. Ltd.
- 04/3247—Barbara Investments Pty. Ltd.
- 04/3248—Barbara Investments Pty. Ltd.
- 04/3249—Barbara Investments Pty. Ltd.
- 04/3250—Barbara Investments Pty. Ltd.
- 04/3251—Barbara Investments Pty. Ltd.
- 04/3252—Barbara Investments Pty. Ltd.
- 04/3253—Barbara Investments Pty. Ltd.
- 04/3336—Haoma Gold Mines N.L.; Haoma Prospecting  
Pty. Ltd.; North West Mining N.L.; Tari  
Pty. Ltd.
- 04/3349—Haoma Gold Mines N.L.; Haoma Prospecting  
Pty. Ltd.; North West Mining N.L.; Tari  
Pty. Ltd.
- 04/3418—McAllister, Norman Robert.
- 04/3419—McAllister, Norman Robert.
- 04/3426—McAllister, Norman Robert.
- 04/3427—McAllister, Norman Robert.
- 04/3428—McAllister, Norman Robert.
- 04/3429—McAllister, Norman Robert.
- 04/3430—McAllister, Norman Robert.
- 04/3432—McAllister, Norman Robert.
- 04/3433—McAllister, Norman Robert.
- 04/3434—McAllister, Norman Robert.
- 04/3513—Rhodes Diamond Exploration Pty. Ltd.
- 04/3514—Rhodes Diamond Exploration Pty. Ltd.
- 04/3515—Rhodes Diamond Exploration Pty. Ltd.
- 04/3516—Rhodes Diamond Exploration Pty. Ltd.
- 04/3517—Rhodes Diamond Exploration Pty. Ltd.
- 04/3518—Rhodes Diamond Exploration Pty. Ltd.
- 04/3519—Rhodes Diamond Exploration Pty. Ltd.
- 04/3523—Barbara Investments Pty. Ltd.
- 04/3524—Barbara Investments Pty. Ltd.
- 04/3525—Barbara Investments Pty. Ltd.
- 04/3526—Barbara Investments Pty. Ltd.
- 04/3527—Barbara Investments Pty. Ltd.
- 04/3528—Barbara Investments Pty. Ltd.
- 04/3623—C.R.A. Exploration Pty. Limited.
- 04/3624—C.R.A. Exploration Pty. Limited.
- 04/3655—A.S. Mining Ventures Pty. Ltd.
- 04/3712—A.S. Mining Ventures Pty. Ltd.
- 04/3718—A.S. Mining Ventures Pty. Ltd.
- 04/3720—Monarch Petroleum N.L.
- 04/3721—Monarch Petroleum N.L.
- 04/3722—Monarch Petroleum N.L.
- 04/3723—Monarch Petroleum N.L.
- 04/3724—Monarch Petroleum N.L.
- 04/3725—Monarch Petroleum N.L.
- 04/3726—Monarch Petroleum N.L.
- 04/3727—Monarch Petroleum N.L.
- 04/3728—Monarch Petroleum N.L.
- 04/3729—Monarch Petroleum N.L.
- 04/3730—Monarch Petroleum N.L.
- 04/3731—Monarch Petroleum N.L.
- 04/3732—Monarch Petroleum N.L.
- 04/3733—Monarch Petroleum N.L.
- 04/3734—Monarch Petroleum N.L.
- 04/3940—A.S. Mining Ventures Pty. Ltd.
- 04/3941—A.S. Mining Ventures Pty. Ltd.
- 04/3953—Shaw, Frederick William.
- 04/3954—Shaw, Frederick William.
- 04/3955—Shaw, Frederick William.
- 04/3956—Shaw, Frederick William.
- 04/3957—Shaw, Frederick William.
- 04/3958—Shaw, Frederick William.
- 04/4002—A.S. Mining Ventures Pty. Ltd.
- 04/4003—A.S. Mining Ventures Pty. Ltd.
- 04/4017—Barbara Investments Pty. Ltd.
- 04/4018—Barbara Investments Pty. Ltd.
- 04/4019—Barbara Investments Pty. Ltd.
- 04/4020—Barbara Investments Pty. Ltd.
- 04/4021—Barbara Investments Pty. Ltd.
- 04/4022—Barbara Investments Pty. Ltd.
- 04/4023—Barbara Investments Pty. Ltd.
- 04/4024—Barbara Investments Pty. Ltd.
- 04/4025—Barbara Investments Pty. Ltd.
- 04/4133—A.S. Mining Ventures Pty. Ltd.
- 04/4141—Group Mining Consultants Pty. Ltd.
- 04/4142—Group Mining Consultants Pty. Ltd.
- 04/4143—Group Mining Consultants Pty. Ltd.
- 04/4144—Group Mining Consultants Pty. Ltd.
- 04/4148—Group Mining Consultants Pty. Ltd.
- 04/4149—Group Mining Consultants Pty. Ltd.
- 04/4151—Group Mining Consultants Pty. Ltd.
- 04/4152—Group Mining Consultants Pty. Ltd.
- 04/4158—Group Mining Consultants Pty. Ltd.
- 04/4159—Group Mining Consultants Pty. Ltd.
- 04/4161—Group Mining Consultants Pty. Ltd.
- 04/4162—Group Mining Consultants Pty. Ltd.

- 04/4163—Group Mining Consultants Pty. Ltd.  
 04/4164—Group Mining Consultants Pty. Ltd.  
 04/4165—Group Mining Consultants Pty. Ltd.  
 04/4166—Group Mining Consultants Pty. Ltd.  
 04/4167—Group Mining Consultants Pty. Ltd.  
 04/4168—Group Mining Consultants Pty. Ltd.  
 04/4184—Alcoa of Australia Limited.  
 04/4185—Alcoa of Australia Limited.  
 04/4253—Alcoa of Australia Limited.  
 04/4254—Alcoa of Australia Limited.  
 04/4255—Alcoa of Australia Limited.  
 04/4276—Monarch Petroleum N.L.; Magnet Metals Ltd.; Lennard Oil N.L.  
 04/4308—Carr Boyd Minerals Limited; Jones Mining N.L.  
 04/4309—Carr Boyd Minerals Limited; Jones Mining N.L.  
 04/4310—Carr Boyd Minerals Limited; Jones Mining N.L.  
 04/4311—Carr Boyd Minerals Limited; Jones Mining N.L.  
 04/4312—Carr Boyd Minerals Limited; Jones Mining N.L.  
 04/4323—Jones Mining N.L.  
 04/4324—Jones Mining N.L.  
 04/4646—Shaw, Frederick William.  
 04/4647—Shaw, Frederick William.  
 04/4648—Shaw, Frederick William.  
 04/4649—Shaw, Frederick William.  
 04/4650—Shaw, Frederick William.  
 04/4651—Shaw, Frederick William.  
 04/4652—Shaw, Frederick William.  
 04/4653—Shaw, Frederick William.  
 04/4654—Shaw, Frederick William.  
 04/4655—Shaw, Frederick William.  
 04/4656—Shaw, Frederick William.  
 04/4657—Shaw, Frederick William.  
 04/4699—Conex Australia N.L.  
 04/4700—Conex Australia N.L.  
 04/4701—Conex Australia N.L.  
 04/4702—Conex Australia N.L.  
 04/4703—Conex Australia N.L.  
 04/4704—Conex Australia N.L.  
 04/4705—Conex Australia N.L.  
 04/4706—Conex Australia N.L.  
 04/4707—Conex Australia N.L.  
 04/4708—Conex Australia N.L.  
 04/4709—Conex Australia N.L.  
 04/4710—Conex Australia N.L.  
 04/4711—Conex Australia N.L.  
 04/4712—Conex Australia N.L.  
 04/4713—Conex Australia N.L.  
 04/4714—Conex Australia N.L.  
 04/4715—Conex Australia N.L.  
 04/4716—Conex Australia N.L.  
 04/4717—Conex Australia N.L.  
 04/4718—Conex Australia N.L.  
 04/4719—Conex Australia N.L.  
 04/4720—Conex Australia N.L.  
 04/4721—Conex Australia N.L.  
 04/4722—Conex Australia N.L.  
 04/4723—Conex Australia N.L.  
 04/4724—Conex Australia N.L.  
 04/4725—Conex Australia N.L.  
 04/4726—Conex Australia N.L.  
 04/4727—Conex Australia N.L.  
 04/4728—Conex Australia N.L.  
 04/4729—Cultus Pacific N.L.  
 04/4730—Cultus Pacific N.L.  
 04/4731—Cultus Pacific N.L.  
 04/4732—Cultus Pacific N.L.  
 04/4733—Cultus Pacific N.L.  
 04/4734—Cultus Pacific N.L.  
 04/4735—Cultus Pacific N.L.  
 04/4839—Consolidated Resources N.L.  
 04/4840—Consolidated Resources N.L.  
 04/4841—Consolidated Resources N.L.  
 04/4842—Consolidated Resources N.L.  
 04/4843—Consolidated Resources N.L.  
 04/4844—Consolidated Resources N.L.  
 04/4845—Consolidated Resources N.L.  
 04/4846—Consolidated Resources N.L.  
 04/4847—Consolidated Resources N.L.  
 04/4848—Consolidated Resources N.L.  
 04/4849—Consolidated Resources N.L.  
 04/4850—Consolidated Resources N.L.  
 04/4851—Consolidated Resources N.L.  
 04/4852—Consolidated Resources N.L.  
 04/4853—Consolidated Resources N.L.  
 04/4854—Consolidated Resources N.L.  
 04/4868—Arnold Nominees Pty. Ltd.  
 04/4869—Arnold Nominees Pty. Ltd.  
 04/4870—Arnold Nominees Pty. Ltd.  
 04/4871—Arnold Nominees Pty. Ltd.  
 04/4872—Arnold Nominees Pty. Ltd.  
 04/4873—Arnold Nominees Pty. Ltd.  
 04/4874—Arnold Nominees Pty. Ltd.  
 04/4875—Arnold Nominees Pty. Ltd.  
 04/4876—Arnold Nominees Pty. Ltd.  
 04/4877—Arnold Nominees Pty. Ltd.  
 04/4878—Arnold Nominees Pty. Ltd.  
 04/4879—Arnold Nominees Pty. Ltd.  
 04/4880—Arnold Nominees Pty. Ltd.  
 04/4881—Arnold Nominees Pty. Ltd.  
 04/4882—Arnold Nominees Pty. Ltd.  
 04/4883—Arnold Nominees Pty. Ltd.  
 04/4884—Arnold Nominees Pty. Ltd.  
 04/4885—Arnold Nominees Pty. Ltd.  
 04/4886—Arnold Nominees Pty. Ltd.  
 04/4887—Arnold Nominees Pty. Ltd.  
 04/4888—Arnold Nominees Pty. Ltd.  
 04/4889—Arnold Nominees Pty. Ltd.  
 04/4994—Jones Mining N.L.  
 04/4995—Jones Mining N.L.  
 04/5044—Conex Australia N.L.  
 04/5045—Conex Australia N.L.  
 04/5046—Conex Australia N.L.  
 04/5047—Conex Australia N.L.  
 04/5120—Samantha Mines Pty. Ltd.; Metals Exploration Limited.  
 04/5124—Samantha Mines Pty. Ltd.; Metals Exploration Limited.  
 04/5131—Samantha Mines Pty. Ltd.; Metals Exploration Limited.  
 04/5132—Samantha Mines Pty. Ltd.; Metals Exploration Limited.  
 04/5243—Pollock, George Leo; Yovich, Michael; MacLeod, Malcolm.  
 04/5244—Pollock, George Leo; Yovich, Michael; MacLeod, Malcolm.  
 04/5245—Pollock, George Leo; Yovich, Michael; MacLeod, Malcolm.  
 04/5246—Pollock, George Leo; Yovich, Michael; MacLeod, Malcolm.  
 04/5247—Pollock, George Leo; Yovich, Michael; MacLeod, Malcolm.  
 04/5248—Pollock, George Leo; Yovich, Michael; MacLeod, Malcolm.  
 04/5249—Pollock, George Leo; Yovich, Michael; MacLeod, Malcolm.  
 04/5250—Pollock, George Leo; Yovich, Michael; MacLeod, Malcolm.  
 04/5265—Cultus Pacific N.L.  
 04/5271—Monarch Petroleum N.L.; Magnet Metals Ltd.; Lennard Oil N.L.  
 04/5272—Monarch Petroleum N.L.; Magnet Metals Ltd.; Lennard Oil N.L.



- 04/5274—Monarch Petroleum N.L.; Magnet Metals Ltd.; Lennard Oil N.L.
- 04/5275—Monarch Petroleum N.L.; Magnet Metals Ltd.; Lennard Oil N.L.
- 04/5276—Monarch Petroleum N.L.; Magnet Metals Ltd.; Lennard Oil N.L.
- 04/5279—Monarch Petroleum N.L.; Magnet Metals Ltd.; Lennard Oil N.L.
- 04/5280—Monarch Petroleum N.L.; Magnet Metals Ltd.; Lennard Oil N.L.
- 04/5281—Monarch Petroleum N.L.; Magnet Metals Ltd.; Lennard Oil N.L.
- 04/5282—Monarch Petroleum N.L.; Magnet Metals Ltd.; Lennard Oil N.L.
- 04/5283—Monarch Petroleum N.L.; Magnet Metals Ltd.; Lennard Oil N.L.
- 04/5284—Monarch Petroleum N.L.; Magnet Metals Ltd.; Lennard Oil N.L.
- 04/5285—Monarch Petroleum N.L.; Magnet Metals Ltd.; Lennard Oil N.L.
- 04/5286—Monarch Petroleum N.L.; Magnet Metals Ltd.; Lennard Oil N.L.
- 04/5287—Monarch Petroleum N.L.; Magnet Metals Ltd.; Lennard Oil N.L.
- 04/5288—Monarch Petroleum N.L.; Magnet Metals Ltd.; Lennard Oil N.L.
- 04/5289—Monarch Petroleum N.L.; Magnet Metals Ltd.; Lennard Oil N.L.
- 04/5290—Monarch Petroleum N.L.; Magnet Metals Ltd.; Lennard Oil N.L.
- 04/5291—Monarch Petroleum N.L.; Magnet Metals Ltd.; Lennard Oil N.L.
- 04/5292—Monarch Petroleum N.L.; Magnet Metals Ltd.; Lennard Oil N.L.
- 04/5333—Ingram, Peter Anthony John; Ingram, Mary Margaret.
- 04/5378—Pioneer Mines Ltd.
- 04/5402—Pollock, George Leo; Yovich, Michael; MacLeod, Malcolm.
- 04/5403—Pollock, George Leo; Yovich, Michael; MacLeod, Malcolm.
- 04/5404—Pollock, George Leo; Yovich, Michael; MacLeod, Malcolm.
- 04/5527—Yovich, Ian.
- 04/5528—Pollock, Kim George.
- 04/5529—James, Ian Charles.
- 04/5530—James, Ian Charles.
- 04/5531—James, Ian Charles.
- 04/5543—Lightfoot, Philip Ross.
- 04/5544—Lightfoot, Philip Ross.
- 04/5545—Lightfoot, Philip Ross.
- 04/5546—Lightfoot, Philip Ross.
- 04/5578—Hepburn, John Robert; Sorensen, Erik Christian.
- 04/5579—Hepburn, John Robert; Sorensen, Erik Christian.
- 04/5580—Hepburn, John Robert; Sorensen, Erik Christian.
- 04/5581—Hepburn, John Robert; Sorensen, Erik Christian.
- 04/5582—Hepburn, John Robert; Sorensen, Erik Christian.
- 04/5583—Hepburn, John Robert; Sorensen, Erik Christian.
- 04/5584—Cawarra Pty. Ltd.
- 04/5585—Cawarra Pty. Ltd.
- 04/5586—Cawarra Pty. Ltd.
- 04/5587—Cawarra Pty. Ltd.
- 04/5588—Cawarra Pty. Ltd.
- 04/5589—Cawarra Pty. Ltd.
- 04/5590—Cawarra Pty. Ltd.
- 04/5591—Cawarra Pty. Ltd.
- 04/5592—Cawarra Pty. Ltd.
- 04/5593—Cawarra Pty. Ltd.
- 04/5596—Lightfoot, Philip Ross.
- 04/5597—Lightfoot, Philip Ross.
- 04/5598—Lightfoot, Philip Ross.
- 04/5599—Lightfoot, Philip Ross.
- 04/5707—Zukerman, David Nathan.
- 04/5708—Zukerman, David Nathan.
- 04/5709—Zukerman, David Nathan.
- 04/5710—Zukerman, David Nathan.
- 04/5711—Zukerman, David Nathan.
- 04/5712—Zukerman, David Nathan.
- 04/5713—Zukerman, David Nathan.
- 04/5714—Zukerman, David Nathan.
- 04/5718—Zukerman, David Nathan.
- 04/5759—Zukerman, David Nathan.
- 04/5831—Hickey, Michael.
- 04/5832—Hickey, Michael.
- 04/5833—Hickey, Michael.
- 04/5834—Elvet Exploration Pty. Ltd.
- 04/5835—Elvet Exploration Pty. Ltd.
- 04/5836—Elvet Exploration Pty. Ltd.
- 04/5837—Elvet Exploration Pty. Ltd.
- 04/5845—Pollock, Shane George Paul.
- 04/5847—Pollock, George Leo; Yovich, Michael; MacLeod, Malcolm.
- 04/5848—Pollock, George Leo; Yovich, Michael; MacLeod, Malcolm.
- 04/5849—Pollock, George Leo; Yovich, Michael; MacLeod, Malcolm.
- 04/5850—Pollock, George Leo; Yovich, Michael; MacLeod, Malcolm.
- 04/5851—Pollock, George Leo; Yovich, Michael; MacLeod, Malcolm.
- 04/5852—Pollock, George Leo; Yovich, Michael; MacLeod, Malcolm.
- 04/5853—Pollock, George Leo; Yovich, Michael; MacLeod, Malcolm.
- 04/5981—Mallum Exploration Pty. Limited.
- 04/5982—Mallum Exploration Pty. Limited.
- 04/5983—Mallum Exploration Pty. Limited.
- 04/5984—Mallum Exploration Pty. Limited.
- 04/5985—Mallum Exploration Pty. Limited.
- 04/5992—Cawarra Pty. Ltd.
- 04/5993—Cawarra Pty. Ltd.
- 04/5994—Cawarra Pty. Ltd.
- 04/5995—Cawarra Pty. Ltd.
- 04/5996—Cawarra Pty. Ltd.
- 04/5997—Cawarra Pty. Ltd.
- 04/5998—Cawarra Pty. Ltd.
- 04/5999—Cawarra Pty. Ltd.
- 04/6000—Cawarra Pty. Ltd.
- 04/6001—Cawarra Pty. Ltd.
- 04/6002—Cawarra Pty. Ltd.
- 04/6003—Cawarra Pty. Ltd.
- 04/6004—Cawarra Pty. Ltd.
- 04/6005—Cawarra Pty. Ltd.
- 04/6006—Cawarra Pty. Ltd.
- 04/6007—Cawarra Pty. Ltd.
- 04/6008—Cawarra Pty. Ltd.
- 04/6009—Cawarra Pty. Ltd.
- 04/6010—Cawarra Pty. Ltd.
- 04/6011—Cawarra Pty. Ltd.
- 04/6039—Elvet Exploration Pty. Ltd.
- 04/6041—Elvet Exploration Pty. Ltd.
- 04/6042—Elvet Exploration Pty. Ltd.
- 04/6043—Elvet Exploration Pty. Ltd.
- 04/6107—The Stellar Minerals Pty. Ltd.
- 04/6108—The Stellar Minerals Pty. Ltd.
- 04/6109—The Stellar Minerals Pty. Ltd.
- 04/6110—The Stellar Minerals Pty. Ltd.
- 04/6227—Hickey, Michael.
- 04/6248—Pilkington, Brian.
- 04/6249—Pilkington, Brian.
- 04/6250—Pilkington, Brian.
- 04/6251—Pilkington, Brian.

- 04/6252—Pilkington, Brian.  
 04/6253—Pilkington, Brian.  
 04/6254—Pilkington, Brian.  
 04/6255—Pilkington, Brian.  
 04/6256—Pilkington, Brian.  
 04/6257—Pilkington, Brian.  
 04/6258—Pilkington, Brian.  
 04/6259—Pilkington, Brian.  
 04/6260—Pilkington, Brian.  
 04/6261—Pilkington, Brian.  
 04/6262—Pilkington, Brian.  
 04/6264—Hickey, Michael.  
 04/6265—Hickey, Michael.  
 04/6266—Hickey, Michael.  
 04/6267—Hickey, Michael.  
 04/6268—Hickey, Michael.  
 04/6269—Hickey, Michael.  
 04/6270—Elvet Exploration Pty. Ltd.  
 04/6271—Elvet Exploration Pty. Ltd.  
 04/6278—Cawarra Pty. Ltd.  
 04/6279—Cawarra Pty. Ltd.  
 04/6280—Cawarra Pty. Ltd.  
 04/6281—Cawarra Pty. Ltd.  
 04/6282—Cawarra Pty. Ltd.  
 04/6283—Cawarra Pty. Ltd.  
 04/6289—Cawarra Pty. Ltd.  
 04/6290—Cawarra Pty. Ltd.  
 04/6291—Consolidated Resources N.L.  
 04/6292—Consolidated Resources N.L.  
 04/6293—Consolidated Resources N.L.  
 04/6294—Consolidated Resources N.L.  
 04/6295—Consolidated Resources N.L.  
 04/6296—Consolidated Resources N.L.  
 04/6297—Consolidated Resources N.L.  
 04/6304—Hepburn, John Robert; Sorensen, Erik  
                   Christian.  
 04/6305—Hepburn, John Robert; Sorensen, Erik  
                   Christian.  
 04/6306—Hepburn, John Robert; Sorensen, Erik  
                   Christian.  
 04/6307—Hepburn, John Robert; Sorensen, Erik  
                   Christian.  
 04/6308—Hepburn, John Robert; Sorensen, Erik  
                   Christian.  
 04/6309—Hepburn, John Robert; Sorensen, Erik  
                   Christian.  
 04/6310—Hepburn, John Robert; Sorensen, Erik  
                   Christian.  
 04/6311—Hepburn, John Robert; Sorensen, Erik  
                   Christian.  
 04/6312—Hepburn, John Robert; Sorensen, Erik  
                   Christian.  
 04/6313—Hepburn, John Robert; Sorensen, Erik  
                   Christian.  
 04/6314—Hepburn, John Robert; Sorensen, Erik  
                   Christian.  
 04/6315—Hepburn, John Robert; Sorensen, Erik  
                   Christian.  
 04/6316—Hepburn, John Robert; Sorensen, Erik  
                   Christian.  
 04/6317—Hepburn, John Robert; Sorensen, Erik  
                   Christian.  
 04/6318—Hepburn, John Robert; Sorensen, Erik  
                   Christian.  
 04/6368—Solaris Pty. Limited.  
 04/6369—Solaris Pty. Limited.  
 04/6370—Solaris Pty. Limited.  
 04/6371—Solaris Pty. Limited.  
 04/6372—Solaris Pty. Limited.  
 04/6374—Solaris Pty. Limited.  
 04/6375—Solaris Pty. Limited.  
 04/6376—Solaris Pty. Limited.  
 04/6377—Solaris Pty. Limited.  
 04/6378—Solaris Pty. Limited.  
 04/6379—Solaris Pty. Limited.  
 04/6399—Hickey, Michael.  
 04/6400—Hickey, Michael.  
 04/6401—Hickey, Michael.  
 04/6402—Hickey, Michael.  
 04/6414—Elvet Exploration Pty. Ltd.  
 04/6415—Magnum Minerals Pty. Limited.; Openpit  
                   Mining & Exploration Pty. Ltd.  
 04/6416—Magnum Minerals Pty. Limited.; Mining  
                   Mining & Exploration Pty. Ltd.  
 04/6417—Magnum Minerals Pty. Limited.; Openpit  
                   Mining & Exploration Pty. Ltd.  
 04/6418—Magnum Minerals Pty. Limited.; Openpit  
                   Mining & Exploration Pty. Ltd.  
 04/6419—Magnum Minerals Pty. Limited.; Openpit  
                   Mining & Exploration Pty. Ltd.  
 04/6420—Magnum Minerals Pty. Limited.; Openpit  
                   Mining & Exploration Pty. Ltd.  
 04/6421—Magnum Minerals Pty. Limited.; Openpit  
                   Mining & Exploration Pty. Ltd.  
 04/6422—Magnum Minerals Pty. Limited.; Openpit  
                   Mining & Exploration Pty. Ltd.  
 04/6423—Magnum Minerals Pty. Limited.; Openpit  
                   Mining & Exploration Pty. Ltd.  
 04/6424—Magnum Minerals Pty. Limited.; Openpit  
                   Mining & Exploration Pty. Ltd.  
 04/6425—Magnum Minerals Pty. Limited.; Openpit  
                   Mining & Exploration Pty. Ltd.  
 04/6426—Magnum Minerals Pty. Limited.; Openpit  
                   Mining & Exploration Pty. Ltd.  
 04/6427—Magnum Minerals Pty. Limited.; Openpit  
                   Mining & Exploration Pty. Ltd.  
 04/6428—Magnum Minerals Pty. Limited.; Openpit  
                   Mining & Exploration Pty. Ltd.  
 04/6429—Magnum Minerals Pty. Limited.; Openpit  
                   Mining & Exploration Pty. Ltd.  
 04/6430—Magnum Minerals Pty. Limited.; Openpit  
                   Mining & Exploration Pty. Ltd.  
 04/6431—Magnum Minerals Pty. Limited.; Openpit  
                   Mining & Exploration Pty. Ltd.  
 04/6432—Magnum Minerals Pty. Limited.; Openpit  
                   Mining & Exploration Pty. Ltd.  
 04/6433—Magnum Minerals Pty. Limited.; Openpit  
                   Mining & Exploration Pty. Ltd.  
 04/6434—Magnum Minerals Pty. Limited.; Openpit  
                   Mining & Exploration Pty. Ltd.  
 04/6435—Magnum Minerals Pty. Limited.; Openpit  
                   Mining & Exploration Pty. Ltd.  
 04/6436—Pollock, George Leo; Yovich, Michael;  
                   MacLeod, Malcolm.  
 04/6437—Pollock, George Leo; Yovich, Michael;  
                   MacLeod, Malcolm.  
 04/6438—Pollock, George Leo; Yovich, Michael;  
                   MacLeod, Malcolm.  
 04/6439—Pollock, George Leo; Yovich, Michael;  
                   MacLeod, Malcolm.  
 04/6440—Pollock, George Leo; Yovich, Michael;  
                   MacLeod, Malcolm.  
 04/6441—Rennie, Graham Edwin; Scott, Stephen Keith;  
                   Rennie, Cyril Francis.  
 04/6442—Kosovich, Milton Stephen.  
 04/6443—Saunders, Prudence.  
 04/6444—Pollock, George Leo; Yovich, Michael,  
                   MacLeod, Malcolm.  
 04/6445—Elvet Exploration Pty. Ltd.  
 04/6446—Elvet Exploration Pty. Ltd.  
 04/6448—Elvet Exploration Pty. Ltd.  
 04/6629—Pilkington, Brian.  
 04/6630—Pilkington, Brian.  
 04/6631—Pilkington, Brian.  
 04/6633—Pilkington, Brian.  
 04/6634—Pilkington, Brian.  
 04/6635—Pilkington, Brian.  
 04/6636—Pilkington, Brian.  
 04/6667—Monarch Petroleum N.L.  
 04/6668—Monarch Petroleum N.L.  
 04/6669—Monarch Petroleum N.L.

- 04/6670—Monarch Petroleum N.L.  
 04/6671—Monarch Petroleum N.L.  
 04/6672—Monarch Petroleum N.L.  
 04/6673—Monarch Petroleum N.L.  
 04/6674—Monarch Petroleum N.L.  
 04/6675—Monarch Petroleum N.L.  
 04/6677—Monarch Petroleum N.L.  
 04/6678—Monarch Petroleum N.L.  
 04/6679—Monarch Petroleum N.L.  
 04/6680—Monarch Petroleum N.L.  
 04/6681—Monarch Petroleum N.L.  
 04/6682—Monarch Petroleum N.L.  
 04/6683—Monarch Petroleum N.L.  
 04/6684—Conex Australia N.L.  
 04/6788—Hickey, Michael.  
 04/6789—Hickey, Michael.  
 04/6790—Hickey, Michael.  
 04/6791—Hickey, Michael.  
 04/6792—Hickey, Michael.  
 04/6793—Hickey, Michael.  
 04/6794—Hickey, Michael.  
 04/6795—Hickey, Michael.  
 04/6796—Hickey, Michael.  
 04/6797—Hickey, Michael.  
 04/6798—Hickey, Michael.  
 04/6799—Hickey, Michael.  
 04/6800—Hickey, Michael.  
 04/6801—Hickey, Michael.  
 04/6802—Hickey, Michael.  
 04/6803—Hickey, Michael.  
 04/6914—The Stellar Minerals Pty. Ltd.  
 04/6915—The Stellar Minerals Pty. Ltd.  
 04/6916—The Stellar Minerals Pty. Ltd.  
 04/6917—The Stellar Minerals Pty. Ltd.  
 04/6918—The Stellar Minerals Pty. Ltd.  
 04/6919—The Stellar Minerals Pty. Ltd.  
 04/6921—The Stellar Minerals Pty. Ltd.  
 04/6923—The Stellar Minerals Pty. Ltd.  
 04/6924—The Stellar Minerals Pty. Ltd.  
 04/6925—The Stellar Minerals Pty. Ltd.  
 04/6927—The Stellar Minerals Pty. Ltd.  
 04/7087—The Stellar Minerals Pty. Ltd.  
 04/7088—The Stellar Minerals Pty. Ltd.  
 04/7089—Samantha Mines Pty. Ltd.; Metals Exploration Ltd.  
 04/7090—Samantha Mines Pty. Ltd.; Metals Exploration Ltd.  
 04/7091—Samantha Mines Pty. Ltd.; Metals Exploration Ltd.  
 04/7092—Samantha Mines Pty. Ltd.; Metals Exploration Ltd.  
 04/7093—Samantha Mines Pty. Ltd.; Metals Exploration Ltd.  
 04/7094—Samantha Mines Pty. Ltd.; Metals Exploration Ltd.  
 04/7095—Samantha Mines Pty. Ltd.; Metals Exploration Ltd.  
 04/7096—Samantha Mines Pty. Ltd.; Metals Exploration Ltd.  
 04/7113—Metana Minerals N.L.  
 04/7241—Jones Mining N.L.  
 04/7242—Jones Mining N.L.  
 04/7268—Solaris Pty. Limited.  
 04/7269—Solaris Pty. Limited.  
 04/7270—Solaris Pty. Limited.  
 04/7271—Solaris Pty. Limited.  
 04/7425—Samantha Mines Pty. Ltd.; Metals Exploration Ltd.  
 04/7426—Samantha Mines Pty. Ltd.; Metals Exploration Ltd.  
 04/7427—Samantha Mines Pty. Ltd.; Metals Exploration Ltd.  
 04/7428—Samantha Mines Pty. Ltd.; Metals Exploration Ltd.  
 04/7429—Samantha Mines Pty. Ltd.; Metals Exploration Ltd.  
 04/7430—Samantha Mines Pty. Ltd.; Metals Exploration Ltd.  
 04/7431—Samantha Mines Pty. Ltd.; Metals Exploration Ltd.  
 04/7432—Samantha Mines Pty. Ltd.; Metals Exploration Ltd.  
 04/7433—Samantha Mines Pty. Ltd.; Metals Exploration Ltd.  
 04/7519—Pollock, George Leo; Yovich, Michael; MacLeod, Malcolm.  
 04/7520—Pollock, George Leo; Yovich, Michael; MacLeod, Malcolm.  
 04/7521—Pollock, George Leo; Yovich, Michael; MacLeod, Malcolm.  
 04/7522—Pollock, George Leo; Yovich, Michael; MacLeod, Malcolm.  
 04/7523—Pollock, George Leo; Yovich, Michael; MacLeod, Malcolm.  
 04/7524—Oldman, Geoffrey.  
 04/7525—Sardelic, Ivan; Sardelic, Anton.  
 04/7526—Deleo, Donald Peter.  
 04/7527—Pollock, George Leo; Yovich, Michael; MacLeod, Malcolm.  
 04/7528—Pollock, George Leo; Yovich, Michael; MacLeod, Malcolm.  
 04/7529—Pollock, George Leo; Yovich, Michael; MacLeod, Malcolm.  
 04/7530—Pollock, George Leo; Yovich, Michael; MacLeod, Malcolm.  
 04/7531—Pollock, George Leo; Yovich, Michael; MacLeod, Malcolm.  
 04/7532—Pollock, George Leo; Yovich, Michael; MacLeod, Malcolm.  
 04/7543—Australian Consolidated Minerals Ltd.  
 04/7544—Australian Consolidated Minerals Ltd.  
 04/7545—Australian Consolidated Minerals Ltd.  
 04/7556—Australian Consolidated Minerals Ltd.  
 04/7547—Australian Consolidated Minerals Ltd.  
 04/7548—Australian Consolidated Minerals Ltd.  
 04/7549—Australian Consolidated Minerals Ltd.  
 04/7550—Australian Consolidated Minerals Ltd.  
 04/7551—Australian Consolidated Minerals Ltd.  
 04/7552—Australian Consolidated Minerals Ltd.  
 04/7553—Australian Consolidated Minerals Ltd.  
 04/7554—Australian Consolidated Minerals Ltd.  
 04/7719—Australian Consolidated Minerals Ltd.  
 04/7720—Australian Consolidated Minerals Ltd.  
 04/7721—Australian Consolidated Minerals Ltd.  
 04/7722—Australian Consolidated Minerals Ltd.  
 04/7723—Australian Consolidated Minerals Ltd.  
 04/7724—Australian Consolidated Minerals Ltd.  
 04/7725—Australian Consolidated Minerals Ltd.  
 04/7726—Australian Consolidated Minerals Ltd.  
 04/7727—Australian Consolidated Minerals Ltd.  
 04/7728—Australian Consolidated Minerals Ltd.  
 04/7729—Australian Consolidated Minerals Ltd.  
 04/7730—Australian Consolidated Minerals Ltd.  
 04/7731—Australian Consolidated Minerals Ltd.  
 04/7732—Australian Consolidated Minerals Ltd.  
 04/7733—Australian Consolidated Minerals Ltd.  
 04/7734—Australian Consolidated Minerals Ltd.  
 04/7735—Australian Consolidated Minerals Ltd.  
 04/7736—Australian Consolidated Minerals Ltd.  
 04/7737—Australian Consolidated Minerals Ltd.  
 04/7738—Australian Consolidated Minerals Ltd.  
 04/7799—Metana Minerals N.L.  
 04/7800—Metana Minerals N.L.  
 04/7801—Metana Minerals N.L.  
 04/7802—Metana Minerals N.L.  
 04/7803—Metana Minerals N.L.  
 04/7804—Walters, Robert.  
 04/7877—Barrier Exploration N.L.

- 04/7878—Barrier Exploration N.L.  
 04/7879—Barrier Exploration N.L.  
 04/7880—Barrier Exploration N.L.  
 04/7881—Barrier Exploration N.L.  
 04/7882—Barrier Exploration N.L.  
 04/7883—Barrier Exploration N.L.  
 04/7884—Barrier Exploration N.L.  
 04/7922—Samantha Mines Pty. Ltd.; Metals Exploration Ltd.  
 04/7923—Samantha Mines Pty. Ltd.; Metals Exploration Ltd.  
 04/7924—Samantha Mines Pty. Ltd.; Metals Exploration Ltd.  
 04/7930—Samantha Mines Pty. Ltd.; Metals Exploration Ltd.  
 04/7931—Samantha Mines Pty. Ltd.; Metals Exploration Ltd.  
 04/7932—Samantha Mines Pty. Ltd.; Metals Exploration Ltd.  
 04/7933—Samantha Mines Pty. Ltd.; Metals Exploration Ltd.  
 04/7934—Samantha Mines Pty. Ltd.; Metals Exploration Ltd.  
 04/7935—Samantha Mines Pty. Ltd.; Metals Exploration Ltd.  
 04/7936—Samantha Mines Pty. Ltd.; Metals Exploration Ltd.  
 04/7937—Samantha Mines Pty. Ltd.; Metals Exploration Ltd.  
 04/7938—Samantha Mines Pty. Ltd.; Metals Exploration Ltd.  
 04/7939—Samantha Mines Pty. Ltd.; Metals Exploration Ltd.  
 04/7940—Samantha Mines Pty. Ltd.; Metals Exploration Ltd.  
 04/7941—Samantha Mines Pty. Ltd.; Metals Exploration Ltd.  
 04/7942—Samantha Mines Pty. Ltd.; Metals Exploration Ltd.  
 04/7943—Samantha Mines Pty. Ltd.; Metals Exploration Ltd.  
 04/7944—Samantha Mines Pty. Ltd.; Metals Exploration Ltd.  
 04/7945—Samantha Mines Pty. Ltd.; Metals Exploration Ltd.  
 04/7946—Samantha Mines Pty. Ltd.; Metals Exploration Ltd.  
 04/7947—Mistral Mines N.L.  
 04/7948—Mistral Mines N.L.  
 04/7969—Mistral Mines N.L.  
 04/7970—Mistral Mines N.L.  
 04/7997—Samantha Mines Pty. Ltd.; Metals Exploration Ltd.  
 04/7998—Samantha Mines Pty. Ltd.; Metals Exploration Ltd.  
 04/7999—Samantha Mines Pty. Ltd.; Metals Exploration Ltd.  
 04/8001—Samantha Mines Pty. Ltd.; Metals Exploration Ltd.  
 04/8003—Samantha Mines Pty. Ltd.; Metals Exploration Ltd.  
 04/8004—Barrier Exploration N.L.  
 04/8005—Barrier Exploration N.L.  
 04/8006—Barrier Exploration N.L.  
 04/8007—Barrier Exploration N.L.  
 04/8008—Barrier Exploration N.L.  
 04/8009—Barrier Exploration N.L.  
 04/8010—Barrier Exploration N.L.  
 04/8011—Barrier Exploration N.L.  
 04/8012—Barrier Exploration N.L.  
 04/8013—Barrier Exploration N.L.  
 04/8014—Barrier Exploration N.L.  
 04/8015—Barrier Exploration N.L.  
 04/8091—A.S. Mining Ventures Pty. Ltd.  
 04/8092—A.S. Mining Ventures Pty. Ltd.  
 04/8110—Gray, Robert James; Menzel, Bruce Walter; O'Meara, Denis William; Mitchell, Albert Edward.  
 04/8111—Gray, Robert James; Menzel, Bruce Walter; O'Meara, Denis William; Mitchell, Albert Edward.  
 04/8112—Gray, Robert James; Menzel, Bruce Walter; O'Meara, Denis William; Mitchell, Albert Edward.  
 04/8113—Gray, Robert James; Menzel, Bruce Walter; O'Meara, Denis William; Mitchell, Albert Edward.  
 04/8135—Metana Minerals N.L.  
 04/8136—Metana Minerals N.L.  
 04/8138—Metana Minerals N.L.  
 04/8236—Samantha Mines Pty. Ltd.; Metals Exploration Ltd.  
 04/8243—Samantha Exploration N.L.; Metals Exploration Ltd.  
 04/8244—Samantha Exploration N.L.; Metals Exploration Ltd.  
 04/8302—Hepburn, John Robert; Sorensen, Erik Christian.  
 04/8303—Hepburn, John Robert; Sorensen, Erik Christian.  
 04/8304—Hepburn, John Robert; Sorensen, Erik Christian.  
 04/8306—Hepburn, John Robert; Sorensen, Erik Christian.  
 04/8307—Hepburn, John Robert; Sorensen, Erik Christian.  
 04/8308—Hepburn, John Robert; Sorensen, Erik Christian.  
 04/8309—Hepburn, John Robert; Sorensen, Erik Christian.  
 04/8415—Minerals, Mining & Metallurgy Limited.  
 04/8416—Minerals, Mining & Metallurgy Limited.  
 04/8419—Minerals, Mining & Metallurgy Limited.  
 04/8420—Minerals, Mining & Metallurgy Limited.  
 04/8421—Grasso, Rosario.  
 04/8422—Grasso, Rosario.  
 04/8423—Grasso, Rosario.  
 04/8424—Minerals, Mining & Metallurgy Limited.  
 04/8425—Grasso, Rosario.  
 04/8429—Minerals, Mining & Metallurgy Limited.  
 04/8452—Metana Minerals N.L.  
 04/8453—Metana Minerals Ltd.  
 04/8454—Metana Minerals N.L.  
 04/8455—Metana Minerals N.L.  
 04/8456—Metana Minerals N.L.  
 04/8457—Metana Minerals N.L.  
 04/8458—Metana Minerals N.L.  
 04/8459—Metana Minerals N.L.  
 04/8460—Metana Minerals N.L.  
 04/8461—Metana Minerals N.L.  
 04/8643—Wright, Kenneth.  
 04/8645—Johnson, John Bertie.  
 04/8646—Cooper, Brent.  
 04/8663—Yovich, Michael; MacLeod, Malcolm; Pollock, George Leo; Vinci, Charles Anthony.  
 04/8664—Yovich, Michael; MacLeod, Malcolm; Pollock, George Leo.  
 04/8665—Pollock, Jim Loretta.  
 04/8666—Bason, Garth.  
 04/8667—Curedale, Ernie.  
 04/8705—De-Biasi, Dario; Davis, Adrian Erroll; Trask, Frank.  
 04/8706—Metana Minerals N.L.  
 04/8707—Metana Minerals N.L.  
 04/8708—Metana Minerals N.L.  
 04/8737—Amax Iron Ore Corporation.  
 04/8757—Allen, Terrence Michael.  
 04/8771—Metana Minerals N.L.  
 04/8810—Sorensen, Erik Christian; Hepburn, John Robert.

- 04/8811—Sorensen, Erik Christian; Hepburn, John Robert.
- 04/8813—Sorensen, Erik Christian; Hepburn, John Robert.
- 04/8814—Sorensen, Erik Christian; Hepburn, John Robert.
- 04/8816—Sorensen, Erik Christian; Hepburn, John Robert.
- 04/8817—Sorensen, Erik Christian; Hepburn, John Robert.
- 04/8818—Sorensen, Erik Christian; Hepburn, John Robert.
- 04/8819—Sorensen, Erik Christian; Hepburn, John Robert.
- 04/8823—Sorensen, Erik Christian; Hepburn, John Robert.
- 04/8824—Sorensen, Erik Christian; Hepburn, John Robert.
- 04/8825—Sorensen, Erik Christian; Hepburn, John Robert.
- 04/8826—Sorensen, Erik Christian; Hepburn, John Robert.
- 04/8827—Sorensen, Erik Christian; Hepburn, John Robert.
- 04/8828—Sorensen, Erik Christian; Hepburn, John Robert.
- 04/8829—Sorensen, Erik Christian; Hepburn, John Robert.
- 04/8830—Sorensen, Erik Christian; Hepburn, John Robert.
- 04/8835—Sorensen, Erik Christian; Hepburn, John Robert.
- 04/8836—Sorensen, Erik Christian; Hepburn, John Robert.
- 04/8837—Sorensen, Erik Christian; Hepburn, John Robert.
- 04/8840—Sorensen, Erik Christian; Hepburn, John Robert.
- 04/8841—Sorensen, Erik Christian; Hepburn, John Robert.
- 04/8842—Sorensen, Erik Christian; Hepburn, John Robert.
- 04/8843—Sorensen, Erik Christian; Hepburn, John Robert.
- 04/8844—Sorensen, Erik Christian; Hepburn, John Robert.
- 04/8845—Sorensen, Erik Christian; Hepburn, John Robert.
- 04/8846—Sorensen, Erik Christian; Hepburn, John Robert.
- 04/8847—Sorensen, Erik Christian; Hepburn, John Robert.
- 04/8848—Sorensen, Erik Christian; Hepburn, John Robert.
- 04/8849—Sorensen, Erik Christian; Hepburn, John Robert.
- 04/8850—Sorensen, Erik Christian; Hepburn, John Robert.
- 04/8851—Sorensen, Erik Christian; Hepburn, John Robert.
- 04/8852—Sorensen, Erik Christian; Hepburn, John Robert.
- 04/8853—Sorensen, Erik Christian; Hepburn, John Robert.
- 04/8855—Sorensen, Erik Christian; Hepburn, John Robert.
- 04/8856—Sorensen, Erik Christian; Hepburn, John Robert.
- 04/8857—Sorensen, Erik Christian; Hepburn, John Robert.
- 04/8858—Sorensen, Erik Christian; Hepburn, John Robert.
- 04/8859—Sorensen, Erik Christian; Hepburn, John Robert.
- 04/8861—Sorensen, Erik Christian; Hepburn, John Robert.
- 04/8862—Sorensen, Erik Christian; Hepburn, John Robert.
- 04/8864—Sorensen, Erik Christian; Hepburn, John Robert.
- 04/8865—Sorensen, Erik Christian; Hepburn, John Robert.
- 04/9039—Western Gem Pty. Ltd.
- 04/9065—Dampier Mining Company Ltd.
- 04/9075—Dampier Mining Company Ltd.
- 04/9076—Dampier Mining Company Ltd.
- 04/9077—Dampier Mining Company Ltd.
- 04/9078—Dampier Mining Company Ltd.
- 04/9079—Dampier Mining Company Ltd.
- 04/9080—Dampier Mining Company Ltd.
- 04/9081—Dampier Mining Company Ltd.
- 04/9082—Dampier Mining Company Ltd.
- 04/9083—Dampier Mining Company Ltd.
- 04/9117—Northwest Mining N.L.; Haoma Gold Mines N.L.; Haoma Prospecting Pty. Ltd.; Tari Pty. Ltd.
- Dredging Claims.
- 04/01—Coastal Titanium Pty. Ltd.
- 04/185—Pexco Pty. Ltd.; Spargos Exploration N.L.; Bamboo Creek Gold Mines N.L.
- 04/186—Pexco Pty. Ltd.; Spargos Exploration N.L.; Bamboo Creek Gold Mines N.L.
- 04/187—Pexco Pty. Ltd.; Spargos Exploration N.L.; Bamboo Creek Gold Mines N.L.
- 04/189—Pexco Pty. Ltd.; Spargos Exploration N.L.; Bamboo Creek Gold Mines N.L.
- 04/190—Pexco Pty. Ltd.; Spargos Exploration N.L.; Bamboo Creek Gold Mines N.L.
- 04/191—Pexco Pty. Ltd.; Spargos Exploration N.L.; Bamboo Creek Gold Mines N.L.
- 04/343—Metana Minerals N.L.; Consolidated Gold Mining Areas N.L.; Shane Holdings Pty. Ltd.
- 04/346—Metana Minerals N.L.; Consolidated Gold Mining Areas N.L.; Shane Holdings Pty. Ltd.
- 04/347—Metana Minerals N.L.; Consolidated Gold Mining Areas N.L.; Shane Holdings Pty. Ltd.
- 04/348—Metana Minerals N.L.; Consolidated Gold Mining Areas N.L.; Shane Holdings Pty. Ltd.
- 04/349—Metana Minerals N.L.; Consolidated Gold Mining Areas N.L.; Shane Holdings Pty. Ltd.
- 04/350—Metana Minerals N.L.; Consolidated Gold Mining Areas N.L.; Shane Holdings Pty. Ltd.
- 04/351—Metana Minerals N.L.; Consolidated Gold Mining Areas N.L.; Shane Holdings Pty. Ltd.
- 04/352—Metana Minerals N.L.; Consolidated Gold Mining Areas N.L.; Shane Holdings Pty. Ltd.
- 04/353—Metana Minerals N.L.; Consolidated Gold Mining Areas N.L.; Shane Holdings Pty. Ltd.
- 04/354—Metana Minerals N.L.; Consolidated Gold Mining Areas N.L.; Shane Holdings Pty. Ltd.
- 04/355—Metana Minerals N.L.; Consolidated Gold Mining Areas N.L.; Shane Holdings Pty. Ltd.
- 04/356—Metana Minerals N.L.; Consolidated Gold Mining Areas N.L.; Shane Holdings Pty. Ltd.
- 04/357—Metana Minerals N.L.; Consolidated Gold Mining Areas N.L.; Shane Holdings Pty. Ltd.
- 04/358—Metana Minerals N.L.; Consolidated Gold Mining Areas N.L.; Shane Holdings Pty. Ltd.
- 04/359—Metana Minerals N.L.; Consolidated Gold Mining Areas N.L.; Shane Holdings Pty. Ltd.
- 04/360—Metana Minerals N.L.; Consolidated Gold Mining Areas N.L.; Shane Holdings Pty. Ltd.

- 04/361—Metana Minerals N.L.; Consolidated Gold Mining Areas N.L.; Shane Holdings Pty. Ltd.
- 04/362—Metana Minerals N.L.; Consolidated Gold Mining Areas N.L.; Shane Holdings Pty. Ltd.
- 04/363—Metana Minerals N.L.; Consolidated Gold Mining Areas N.L.; Shane Holdings Pty. Ltd.
- 04/364—Metana Minerals N.L.; Consolidated Gold Mining Areas N.L.; Shane Holdings Pty. Ltd.
- 04/365—Metana Minerals N.L.; Consolidated Gold Mining Areas N.L.; Shane Holdings Pty. Ltd.
- 04/366—Metana Minerals N.L.; Consolidated Gold Mining Areas N.L.; Shane Holdings Pty. Ltd.
- 04/367—Metana Minerals N.L.; Consolidated Gold Mining Areas N.L.; Shane Holdings Pty. Ltd.
- 04/368—Metana Minerals N.L.; Consolidated Gold Mining Areas N.L.; Shane Holdings Pty. Ltd.
- 04/369—Metana Minerals N.L.; Consolidated Gold Mining Areas N.L.; Shane Holdings Pty. Ltd.
- 04/370—Metana Minerals N.L.; Consolidated Gold Mining Areas N.L.; Shane Holdings Pty. Ltd.
- 04/371—Metana Minerals N.L.; Consolidated Gold Mining Areas N.L.; Shane Holdings Pty. Ltd.
- 04/372—Metana Minerals N.L.; Consolidated Gold Mining Areas N.L.; Shane Holdings Pty. Ltd.
- 04/373—Metana Minerals N.L.; Consolidated Gold Mining Areas N.L.; Shane Holdings Pty. Ltd.
- 04/374—Metana Minerals N.L.; Consolidated Gold Mining Areas N.L.; Shane Holdings Pty. Ltd.
- 04/375—Metana Minerals N.L.; Consolidated Gold Mining Areas N.L.; Shane Holdings Pty. Ltd.
- 04/376—Metana Minerals N.L.; Consolidated Gold Mining Areas N.L.; Shane Holdings Pty. Ltd.
- 04/377—Metana Minerals N.L.; Consolidated Gold Mining Areas N.L.; Shane Holdings Pty. Ltd.
- 04/378—Metana Minerals N.L.; Consolidated Gold Mining Areas N.L.; Shane Holdings Pty. Ltd.

---

MINING ACT 1904.

Forfeiture of Leases for Non-payment of Rent Due under Section 98 of the Mining Act 1904.

Department of Mines,  
Perth, 26 August 1981.

IT is hereby notified for public information that His Excellency the Administrator in Executive Council declared the undermentioned Leases forfeited for breach of covenant, viz., non-payment of rent.

D. R. KELLY,  
Under Secretary for Mines.

ASHBURTON GOLDFIELD.

Mineral Lease.

- 122—Gift; Rose, William; Camp, Frederick John; Griffiths, Frederick Arnold; James, Robert John; Camp, Stanley George.

GASCOYNE GOLDFIELD.

Gold Mining Lease.

- 09/79—Eldorado; Gurney, Kenneth Walter.

COOLGARDIE GOLDFIELD.

*Coolgardie District.*

Gold Mining Leases.

- 15/6299—Centenary; Cahill, Graham John; Pascoe, David; Thomas, Benjamin Leonard.
- 15/6472—Beths Find; Lee, Gary Raymond.
- 15/6474—Jims Jag; McKay, James Frederick; McKay, Kevin Roy.
- 15/6486—Leo; Connelly, Michael Ashley; Pinniger, William.
- 15/6685—Rasim; Karafil, Radium John; Pinkus, Peter Clifford; Channing, Geoff Arthur.
- 15/6689—Little Dido; Dawson, John; Day, Mavis Joyce.
- 15/6711—Suvas Luck; Black, Lyall William.
- 15/6722—Rayphyl; Williams, Phyllis Leila; Marquand, Raymond Leslie.

*Kunanalling District.*

Gold Mining Leases.

- 16/1133—Thend; Smith, Louis.
- 16/1223—Mitchells New Credo Find; Wilson, Lyle George.

EAST COOLGARDIE GOLDFIELD.

*East Coolgardie District.*

Gold Mining Leases.

- 26/7309—Mergie; Menzies, Wayne Douglas; Kellond, Jamie Robert; Kellond, Robert Daniel.

NORTH COOLGARDIE GOLDFIELD.

*Menzies District.*

Gold Mining Leases.

- 29/6035—Kurrajong East; Douch, John William; Boase, John Edward.
- 29/6036—Kurrajong; Douch, John William; Boase, John Edward.

*Yerilla District.*

Gold Mining Leases.

- 31/1553—Salted Pig; Lord, William George.

EAST MURCHISON GOLDFIELD.

*Wiluna District.*

Gold Mining Leases.

- 53/828—Purple Patch; Zuks, Nicholas.

*Black Range District.*

Gold Mining Leases.

- 57/1289—Johns Block; Alman Holdings Pty. Ltd.

*Lawlers District.*

Gold Mining Leases.

- 36/1437—Yellow Aster Minor; Yellow Aster Mines Pty. Ltd.

MOUNT MARGARET GOLDFIELD.

*Mount Malcolm District.*

Gold Mining Leases.

- 37/2064—Gambier Lass; Suraski, John Francis, Martin, John McNeil.
- 37/2475—Diorite; Caruso, Victor Michael.
- 37/2476—Diorite North; Caruso, Victor Michael.
- 37/2478—Stuarts Hole; Riley, Alfred Anthony.

*Mount Margaret District.*

Gold Mining Leases.

- 38/2854—Jerringa; Hill, Peter Augustine.
- 38/2859—Edinboro Castel South; Polmear, Lindsay Keith; Cottam, Maxwell.
- 38/2860—Edinboro Castle; Polmear, Lindsay Keith.
- 38/2861—Joe Plus; Polmear, Lindsay Keith; Cottam, Maxwell.
- 38/2862—Shirley Joyce; Polmear, Lindsay Keith; Cottam, Maxwell.

- 38/2948—Cork Tree Well North West; Whim Creek Consolidated N.L.  
 38/2949—Cork Tree Well West; Whim Creek Consolidated N.L.  
 38/2950—Mocking Bird; Fletcher, Maxwell Charles.

*Mount Morgans District.*

## Gold Mining Leases.

- 39/726—Good Hope Mine; Tucker, Leslie Alfred.  
 39/725—Good Hope Mine South; Tucker, Leslie Alfred.  
 39/726—Good Hope Mine; Tucker, Leslie Alfred.  
 39/727—Danny's Choice; Logue, William John; Harris, Danny.  
 39/764—Susie; Rymer, Harold Arthur; Crocker, Clifford Ron.

## NORTH COOLGARDIE GOLDFIELD.

*Niagara District.*

## Gold Mining Leases.

- 40/1062—Melita; Tucker, Leslie Alfred.  
 40/1063—Melita West; Tucker, Leslie Alfred.  
 40/1064—Melita North; Tucker, Leslie Alfred.  
 40/1065—Melita East; Tucker, Leslie Alfred.

## MURCHISON GOLDFIELD.

*Cue District.*

## Gold Mining Leases.

- 20/2498—Judith May; Duckam, Bruce William.

## MURCHISON GOLDFIELD.

*Meekatharra District.*

## Gold Mining Leases.

- 51/2368—Alex's Patch; Kyanga, John Charles; Cameron, Clarence Edward.  
 51/2369—Marlenes Patch; Kyanga, John Charles; Cameron, Clarence Edward.  
 51/2385—Timbuctoo; Andrews, Ronald Geoffrey; Doust, Arthur.  
 51/2388—Lorna; Zadow, Allan John.  
 51/2435—King & I; King, Alex Norman; Sidebottom, Brent.  
 51/2441—Kaka Mine; Donatti, Peter John; King, Alex Norman; Sidebottom, Brent.  
 51/2442—Royal Nugget; Donatti, Peter John; King, Alex Norman; Sidebottom, Brent.  
 51/2451—Hillside; Sidebottom, Brent; King, Alex Norman; Donatti, Peter John.  
 51/2474—Captain Beaky; Wilson, Donald Lewis.  
 51/2504—Petaleuil; Kristiansen, Peter Cecil.  
 Machinery Lease.  
 51/3 (110H)—Desortion; AMV Nominees Pty. Ltd.

## YALGOO GOLDFIELD.

## Gold Mining Leases.

- 59/1285—Austin Martha; Grose, Albert Franklin.  
 59/1286—Northern Queen; Grose, Albert Franklin.  
 59/1373—Bonnie Brae; Chandilla Exploration Pty. Ltd.  
 59/1374—Bonnie Brae North; Chandilla Exploration Pty. Ltd.  
 59/1405—Kylie Linda; Monarch Petroleum N.L.  
 59/1406—Kylie Hotel; Monarch Petroleum N.L.  
 59/1407—Kylie Golf; Monarch Petroleum N.L.  
 59/1408—Kylie Juliet; Monarch Petroleum N.L.  
 59/1409—Kylie Kilo; Monarch Petroleum N.L.  
 59/1410—Kylie Lima; Monarch Petroleum N.L.  
 59/1411—Kylie Alpha; Monarch Petroleum N.L.  
 59/1412—Kylie Bravo; Monarch Petroleum N.L.  
 59/1413—Kylie Chocolate; Monarch Petroleum N.L.  
 59/1414—Kylie Delta; Monarch Petroleum N.L.  
 59/1415—Kylie Echo; Monarch Petroleum N.L.  
 59/1416—Kylie Foxtrot; Monarch Petroleum N.L.  
 59/1417—Kylie Papa; Monarch Petroleum N.L.  
 59/1418—Kylie Oscar; Monarch Petroleum N.L.

- 59/1419—Kylie November; Monarch Petroleum N.L.  
 59/1420—Kylie Mike; Monarch Petroleum N.L.  
 59/1421—Kylie Tango; Monarch Petroleum N.L.  
 59/1422—Kylie Sierra; Monarch Petroleum N.L.  
 59/1423—Kylie Romeo; Monarch Petroleum N.L.  
 59/1424—Kylie Quebec; Monarch Petroleum N.L.  
 59/1425—Kylie Uniform; Monarch Petroleum N.L.  
 59/1426—Kylie Victor; Monarch Petroleum N.L.  
 59/1427—Kylie Whisky; Monarch Petroleum N.L.  
 59/1428—Kylie X-Ray; Monarch Petroleum N.L.  
 59/1429—Kylie Yankee; Monarch Petroleum N.L.  
 59/1430—Kylie Zulu; Monarch Petroleum N.L.  
 59/1431—Kylie Marion; Monarch Petroleum N.L.  
 59/1432—Kylie Pauline; Monarch Petroleum N.L.  
 59/1433—Kylie Colleen; Monarch Petroleum N.L.  
 59/1434—Kylie Maxwell; Monarch Petroleum N.L.  
 59/1435—Kylie Valerie; Monarch Petroleum N.L.  
 59/1436—Kylie Pierre; Monarch Petroleum N.L.  
 59/1437—Kylie Johnson; Monarch Petroleum N.L.  
 59/1438—Kylie Craigie; Monarch Petroleum N.L.  
 59/1439—Kylie Nixon; Monarch Petroleum N.L.  
 59/1440—Kylie Deek; Monarch Petroleum N.L.  
 59/1441—Kylie Paul; Monarch Petroleum N.L.  
 59/1442—Kylie Zladimir; Monarch Petroleum N.L.  
 59/1443—Kylie Glenway; Monarch Petroleum N.L.  
 59/1444—Kylie Watergate; Monarch Petroleum N.L.  
 59/1445—Kylie Stevenage; Monarch Petroleum N.L.  
 59/1446—Kylie Edson; Monarch Petroleum N.L.

## PILBARA GOLDFIELD.

*Marble Bar District.*

## Gold Mining Leases.

- 45/1465—North Star Reef; Dorph-Peterson, Charles Viggo; Smith, William Allan; Endeavour Resources Limited.  
 45/1581—Jo-Di; Keen, Gordon Eric.  
 45/1637—Hidden Valley; Heitkonig; John Theodore Frederick.

*Nullagine District.*

## Gold Mining Lease.

- 46/411—Little Linden; Leonhardt; Robert Carl; Anick, John Joseph.

## NORTHAMPTON MINERAL FIELD.

## Mineral Leases.

- 66/305—Ray; Ridley, John Thomas; Ridley, Raymond.  
 66/306—John; Ridley, Raymond; Ridley, John Thomas.  
 66/308—Rons; Ridley, Raymond; Ridley, John Thomas.  
 66/309—Annes; Ridley, Raymond; Ridley, John Thomas.  
 66/310—Toms; Ridley, Raymond; Ridley, John Thomas.

## SOUTH WEST MINERAL FIELD.

## Mineral Lease.

- 70/447—Jane; Jennings Industries (W.A.) Limited.

## PHILLIPS RIVER GOLDFIELD.

## Mineral Lease.

- 460—Queen Anne; Pickhands Mather & Co. International.

## YILGARN GOLDFIELD.

## Mineral Leases.

- 77/4919—Bronzewing; Fotios, George Harold; Davidson, William Ewan; Davidson, John Ewen.  
 77/4920—Bon Ami; Fotios, George Harold; Davidson, William Ewan; Davidson, John Ewen.  
 77/4992—Sharon; Brooker, George Arthur; Bovell, Ronald William.

## MINING ACT 1904

Department of Mines  
Perth, 26th August, 1981.

IN accordance with the provisions of the Mining Act 1904 His Excellency the Governor in Executive Council has been pleased to deal with the following mining tenements and Temporary Reserves.

D. R. KELLY,  
Under Secretary for Mines.

The undermentioned applications for Leases were approved conditionally:

## GOLD MINING LEASES

Goldfield	District	No. of Applications
Ashburton		08/69, 08/93
Gascoyne		09/82
Coolgardie	Coolgardie	15/6871, 15/6921, 15/6922, 15/6956, 15/6903 and 15/6973 to 15/6976
Coolgardie	Kunanalling	16/1265, 16/1291
Murchison	Cue	20/2595
Broad Arrow		24/2525, 24/2748, 24/2815 and 24/2816
North Coolgardie	Menzies	29/6060 and 29/6136
North Coolgardie	Ularring	30/1394 to 30/1397
North Coolgardie	Yerilla	31/1570 to 31/1572
East Murchison	Lawlers	36/1512 to 36/1514, 36/1536 to 36/1540, 36/1616 to 36/1618, 36/1620, 36/1621 and 36/1663
Mt. Margaret	Mt. Malcolm	37/2122, 37/2123, 37/2472 to 37/2474, 37/2581, 37/2859, 37/2862 to 37/2878, 37/2882 to 37/2889, 37/2922, 37/2927, 37/2963 to 37/2967 and 37/2975
Mt. Margaret	Mt. Margaret	38/2823, 38/3018, 38/3045 to 38/3048, 38/3049 and 38/3050.
Mt. Margaret	Mt. Morgans	39/968 and 39/973
Pilbara	Marble Bar	45/1701A and 45/1747
Pilbara	Nullagine	46/440
Murchison	Meekatharra	51/2387, 51/2498, 51/2499, 51/2710 to 51/2713, 51/2731, 51/2733, 51/2736 to 51/2739, 51/2740 and 51/2741.
Peak Hill		52/756 and 52/844
East Murchison	Wiluna	53/845 to 53/852
Murchison	Mt. Magnet	58/2051 to 58/2058, 58/2060, 58/2061, 58/2063, 58/2186, 58/2291, 58/2292
Yalgoo		59/1459, 59/1600 and 59/1601
Dundas		63/2848 and 63/2850
Yilgarn		77/5054, 77/5133
Kimberley		80/153 to 80/159, 80/306 to 80/309

## MINERAL LEASES

Goldfield	District	No. of Applications
Coolgardie	Coolgardie	15/620, 15/623 and 15/641 to 15/647

The undermentioned applications for Gold Mining Leases were refused:

Goldfield	No. of Application
Broad Arrow	24/2546
Mt. Margaret	39/763
Murchison	51/2718
East Murchison	53/839 to 53/842

The undermentioned application for a Miner's Homestead Lease was refused:

Goldfield	No. of Application
Murchison	51/72

The undermentioned applications for Authority to Mine on Reserved and Exempted Lands were approved conditionally:

Authority to Mine No.	Tenement No.	Goldfield
16/100 and 16/101	Mineral Claims 16/1476 and 16/1477	Coolgardie
24/160	Mineral Claim 24/1853	Broad Arrow
24/198	Mineral Claim 24/2061	Broad Arrow
37/647	Mineral Claim 37/6705	Mt. Margaret
37/748	Mineral Claim 37/7229	Mt. Margaret
39/178	Mineral Claim 39/4926	Mt. Margaret
47/590, 47/593, 47/594 and 47/591	Mineral Claims 47/4649, 47/4664, 47/4665 and 47/4684	West Pilbara
51/305	Mineral Claim 51/4121	Murchison
58/117	Mineral Claim 58/2339	Murchison
58/118	Mineral Claim 58/2289	Murchison



MINING ACT 1904—*continued.*

The undermentioned Licences to Treat Tailings were renewed for a further period expiring on 31/3/82.

Goldfield	District	Licence No.
East Coolgardie	East Coolgardie	26/77 (2264H) to 26/78 (2265H)

The undermentioned Licence to Treat Tailings was renewed for a further period expiring on 14/4/82

Goldfield	District	Licence No.
East Murchison	Wiluna	53/23 (2681H)

The undermentioned Licence to Treat Tailings was renewed for a further period expiring on 25/5/82.

Goldfield	District	Licence No.
Yilgarn		77/184 (2921H)

The undermentioned Licence to Treat Tailings was renewed for a further period expiring on 11/5/82.

Goldfield	District	Licence No.
Yilgarn		77/202 (2962H)

The undermentioned Licence to Remove and Treat Tailings was renewed for a further period expiring on 28/10/81

Goldfield	District	Licence No.
Mt. Margaret	Mt. Morgans	39/28 (2886H)

The undermentioned application for a Licence to Treat Tailings was refused:

Goldfield	Licence No.
Yilgarn	77/318 (4273H)

The rights of occupancy for the undermentioned Reserves have been renewed:

No.	Occupant	for a further expiring period on	Locality	Goldfield
5610H and 5611H	Alumax Bauxite Corporation	30/6/1982	Situated at various localities	West Kimberley and Kimberley
5612H, 5613H and 5614H	Alumax Bauxite Corporation	30/6/1982	Situated at various localities	Kimberley
6683H	Hamersley Iron Pty. Limited	20/4/1982	Situated at Mt. Tom Price	West Pilbara
6975H to 6980H, 6982H and 6983H	Hamersley Exploration Pty. Ltd.	10/5/1982	Situated at various localities	West Pilbara and Peak Hill
7009H, 7010H, and 7011H	Swan Resources Limited	10/5/1982	Situated at King George River—Beta Creek area	Kimberley
7050H	Lenkane Exploration Pty. Ltd.	24/5/1982	Situated at Kitchener	North East Coolgardie
7087H	Peko Wallsend Operations Ltd.	5/7/1982	Situated at Mt. Caudan	Yilgarn
7658H	Hamersley Exploration Pty. Ltd.	3/7/1982	Situated 16 kilometres north easterly of Marraluna Pool	West Pilbara and Peak Hill
7662H and 7664H	Oilmin N.L., Petromin N.L. and Transoil N.L.	19/6/1982	Situated at various localities	Pilbara
7671H and 7672H	Western Mining Corporation Limited	17/7/1982	Situated at Dunnsville	Coolgardie
7687H and 7688H	Peko Wallsend Operations Ltd.	3/7/1982	Situated at Spring Hill Gold Mine and Cheritons	Yilgarn

## COMPANIES ACT 1961-1979.

(Section 254 (2) (b).)

Creditors' Voluntary Winding Up.

Galerea Nominees Pty Ltd.

NOTICE is hereby given that at a general meeting of members of Galerea Nominees Pty Ltd duly convened and held on 24 August 1981 it was resolved that the company be wound up voluntarily. At the meeting of creditors of the company convened on the same day in accordance with section 260 of the Companies Act 1961-1979 John Hamilton McRae Campbell was appointed Liquidator.

Dated this 28th day of August, 1981.

J. H. M. CAMPBELL,  
Liquidator.

(Peat Marwick Mitchell & Co, Chartered Accountants,  
191 St. George's Terrace, Perth, W.A. 6000.)

## COMPANIES ACT 1961-1979.

(Section 254 (2).)

Notice of Resolution.

Harthel Pty. Ltd.

NOTICE is hereby given that at an extraordinary general meeting of members of the abovenamed company held on 28 August 1981 the following special resolution was duly passed:—

That the company be wound up voluntarily and that A. E. Boddington be appointed as liquidator for the purposes of such winding up, and that the liquidator be authorised to divide all or such part of the surplus assets of the company as he shall think fit amongst the members of the company *in specie*.

Dated this 28th day of August, 1981.

A. E. BODDINGTON,  
Liquidator.

(Peat Marwick Mitchell & Co., 191 St. George's  
Terrace, Perth, W.A.)

## COMPANIES ACT 1961-1979.

Notice of Special Resolution.

Warburton Holdings Pty. Ltd.

NOTICE is hereby given that at an Extraordinary Meeting of the Members of Warburton Holdings Pty. Ltd. held on 28 August 1981 the following Special Resolution was passed:—

That the company be wound up under the provisions applicable to a Members' Voluntary Liquidation, and that Noel Edward Guthrie and Diana Denise Newman hereby be appointed the joint liquidators of the company, with the right to act solely as required and that the liquidators are hereby authorised to distribute *in specie* such of the assets as they see fit and on such conditions as they deem necessary to any one or more of the members of the company.

Notice to Creditors.

Creditors and others having claims against the assets of Warburton Holdings Pty. Ltd. are advised that we shall proceed to distribute the assets of the company on the expiration of 21 days of this date.

Proof of Debt must be lodged with us at care of C. P. Bird & Associates, 18 St. George's Terrace, Perth on or before 5.00 p.m. on 29 September 1981.

Claimants failing to so prove their debts by that date will be excluded from the distribution.

Dated this 31st day of August, 1981.

N. E. GUTHRIE,  
Liquidator.

D. D. NEWMAN,  
Liquidator.

(Messrs. C. P. Bird & Associates, Chartered Accountants,  
18 St. George's Terrace, Perth.)

## COMPANIES ACT 1961-1979.

NOTICE is hereby given in accordance with section 254 (2) of the Companies Act 1961-1979, that an extraordinary general meeting of Johnston Corporation Pty. Ltd. duly convened and held on 28 August 1981, the following resolution was duly passed:—

That the Company be wound up voluntarily.

Dated this 1st day of September, 1981.

ALAN RAYMOND DOUGHTY,  
Liquidator.

## COMPANIES ACT 1961-1979.

(Section 254 (2).)

Notice of Resolution.

C. B. Bethell Pty. Ltd.

NOTICE is hereby given that at an Extraordinary General Meeting of the Members of C. B. Bethell Pty. Ltd. held at 17 Wittenoorn Street, East Perth on 31 August 1981 the special resolution set out below was duly passed:—

That the Company be wound up voluntarily and that Bevan Alfred Hughes be appointed Liquidator of the Company.

Dated at East Perth the 31st day of August, 1981.

B. A. HUGHES,  
Liquidator.

(Lodged by: Armstrong Matcham Hughes & Ross, 17  
Wittenoorn Street, East Perth, W.A. 6000.)

## COMPANIES ACT 1961-1979.

Notice of Intention to Declare a First Dividend.

Strawrime Pty. Ltd. (in Liquidation).

NOTICE is hereby given that as Liquidator of the abovenamed Company, I Maurice Hodgson Lyford, Chartered Accountant of Melsom Wilson & Partners, 11th Floor, T. & G. Building, 37 St. George's Terrace, Perth, intend to declare a first dividend in this matter.

Creditors must prove their debts by 18 September 1981.

Dated at Perth this 1st day of September, 1981.

M. H. LYFORD,  
Liquidator.

(Melsom Wilson & Partners, 11th Floor, T. & G.  
Building, 37 St. George's Terrace, Perth, W.A. 6000.)

## COMPANIES ACT 1961.

Geosearch Pty. Limited (in voluntary liquidation).

Notice of Resolution.

AT an extraordinary general meeting of members of the abovenamed company duly convened and held at 47 Macquarie Street, Sydney on 28 August 1981, the resolution set out below was passed as a special resolution—

That the company be voluntarily wound up and that Alfred Barclay Cleland, Chartered Accountant of 2nd Floor, 15-19 Bent Street, Sydney be appointed liquidator at 12 o'clock noon on 31 August 1981 for the purpose of such winding up and that the liquidator may divide among the contributories in specie or kind the whole or any part of the assets of the company and that Alfred Barclay Cleland shall be entitled to charge and be paid in accordance with the scale of fees as set by the Bankruptcy Trustees and Liquidators Association of Australia.

Dated this 31st day of August, 1981.

J. N. ELLISTON,  
Director.

## COMPANIES ACT 1961.

Production Equipment (W.A.) Pty. Ltd.  
(in voluntary liquidation).

## Notice of Resolution.

AT an extraordinary general meeting of members of the abovenamed company duly convened and held at 98 Fairbank Road, Clayton, Victoria on 31 August 1981, the resolution set out below was passed as a special resolution—

That the company be voluntarily wound up and that Alfred Barclay Cleland, Chartered Accountant of 2nd Floor, 15-19 Bent Street, Sydney be appointed liquidator at 12 o'clock noon on 31 August 1981 for the purpose of such winding up and that the liquidator may divide among the contributories in specie or kind the whole or any part of the assets of the company and that Alfred Barclay Cleland shall be entitled to charge and be paid in accordance with the scale of fees as set by the Bankruptcy Trustees and Liquidators Association of Australia.

Dated this 31st day of August, 1981.

J. H. HALL,  
Secretary.

## TRUSTEES ACT 1962.

Frederick Gorman, late of 34 Watling Avenue, Lynwood in the State of Western Australia, Butcher, deceased.

CREDITORS and other persons who have claims (to which section 63 of the Trustees Act 1962 (as amended) relates) in respect of the abovenamed deceased who died on 22 May 1981 at Nedlands in the State of Western Australia are required by the Administrator Frederick Anthony Gorman of care of Messrs. Talbot & Olivier, Solicitors of 524 Hay Street, Perth in the said State to send particulars of their claims to him by 2 October 1981, after which date the Administrator may convey or distribute the assets having regard only to the claims of which he then has notice.

Dated this 26th day of August, 1981.

TALBOT & OLIVIER,  
Solicitors for the Administrator.

(Talbot & Olivier, Third Floor, 524 Hay Street, Perth, W.A. 6000.)

## TRUSTEES ACT 1962.

CREDITORS and other persons having claims in respect of the estate of Charlotte May Tassell late of Elanora Villas, Hastie Street, Bunbury (to which section 63 of the Trustees Act 1962 as amended applies) are required to send particulars of their claims to the Executrix Dorothy Jean Piper of 104 Mangles Street, Bunbury care of Young & Young incorporating Jenour & Eastmans, 5 Spencer Street, Bunbury by 30 September 1981 after which date the said Executrix may convey or distribute the assets having regard only to the claims of which she has notice and the said Executrix shall not be liable to any person of whose claim she has had no notice at the time of administration or distribution.

Dated this 26th day of August 1981.

YOUNG & YOUNG,  
Incorporating Jenour & Eastmans  
for the Executrix.

## TRUSTEES ACT 1962.

In the matter of the Estate of Walter Thomas Bower late of 8 Viewway Nedlands in the State of Western Australia, Retired Accountant, Deceased.

CREDITORS and other persons who have claims to which section 63 of the Trustees Act 1962 (as amended) relates in respect of the estate of the abovenamed deceased who died on 3 February 1981 at Nedlands in the State of Western Australia are required by the Executrix of his estate, Mildred Bower of 8 Viewway Nedlands to send particulars of their claims to her at the address hereunder by 30 September 1981, after which date the Executrix may convey or distribute the assets, having regard only to the claims of which she has notice.

Dated the 28th day of August, 1981.

BOSTOCK & RYAN,  
Solicitors for the Executrix.

(Bostock & Ryan, First Floor, 178 St. George's Terrace, Perth, W.A. 6000.)

## TRUSTEES ACT 1962.

## Notice to Creditors and Claimants.

WEST AUSTRALIAN TRUSTEES LIMITED of 135 St. George's Terrace, Perth, requires creditors and other persons having claims (to which section 63 of the Trustees Act 1962 relates) in respect of the estates of the undermentioned deceased persons, to send particulars of their claims to it by the date stated hereunder, after which date the Company may convey or distribute the assets, having regard only to the claims of which it then has notice.

Last Day for Claims: 4/10/81.

Black, Laura Jessie, late of 57 Holland Street, Fremantle, Home Duties, died 11/6/81.

Green, Violet Alexandra Elizabeth Vivian, late of 220 Canning Highway, South Perth, Widow, died 2/7/81.

Lawson, Emily, formerly of 115 Bussell Highway, Busselton late of P.C.U. District Hospital, Busselton, Widow, died 12/6/81. (Enquiries to 11 Stirling Street, Bunbury Tel: 21 1336.)

Memory, George Henry, late of The Braille Hospital, Kitchener Avenue, Victoria Park, Retired Baker, died 17/7/81.

O'Donnell, Margaret Julia Anna, late of Mount Henry Hospital, Cloister Avenue, Como, Spinster, died 25/7/81.

Dated at Perth this 2nd day of September, 1981.

L. C. RICHARDSON,  
General Manager.

## TRUSTEES ACT 1962.

## Notice to Creditors and Claimants.

CREDITORS and other persons having claims (to which section 63 of the Trustees Act relates) in respect of the Estates of the undermentioned deceased persons are required to send particulars of their claims to me on or before 5 October 1981, after which date I may convey or distribute the assets, having regard only to the claims of which I then have notice.

Andry, Charles (also known as Andryszczak Czeslaw), late of 41 Norfolk Street, North Perth, Watchmaker and Jeweller, died 3/8/81.

Arnold, Gladys Thorley, late of 10 Joyce Street, Dalkeith, Married Woman, died 14/8/81.

Baxter, Henry Herbert James, late of 66 Gosnells Road, Gosnells, Retired Storeman, died 27/5/81.

Berry, Ivan Read, late of 23 Athlone Road, Floreat Park, Retired State Civil Servant, died 10/8/81.

Boult, Stanley Colin, late of 217 Preston Point Road, Bicton, Retired Production Manager, died 8/8/81.

Brindley, Isabel Mary, late of 204 Ravenscar Street, Doubleview, Widow, died 6/8/81.

Brown, Elsie Maud, late of 68 Kishorn Road, Mt. Pleasant, Widow, died 30/7/81.

Cahill, Gordon Charles, late of 13 Harcourt Street, Inglewood, Retired Secretary, died 14/8/81.

Curedale, Robert Gordon, late of Unit 6/17 Kirkham Hill Terrace, Maylands, Retired Geophysicist, died 18/7/81.

Dodds, Francis Tullan Kendall, late of 47 Stead Street, Maddington, Retired Miller, died 21/6/81.

Finlay, Irene, late of 16 Gladstone Street, St. James, Widow, died 21/7/81.

Hendon, Arthur Edward Perry, late of 48 Yilgarn Street, Shenton Park, Retired Storeman, died 10/8/81.

Johnston, Mabel Mary late of 98 Attfield Street, South Fremantle, Widow, died 18/8/81.

Kalman, Eileen Mary, formerly of Unit 3, 260 Cambridge Street, Wembley, late of Homes of Peace, Thomas Road, Subiaco, Widow, died 13/7/81.

Kwan, Sai Ho (also known as Kwan, John Saiho), late of 6 Tintal Place, Kardinya, Student, died 14/12/80.

Leunig, Jack William, late of 29 Walter Street, Gosnells, Retired Salesman, died 14/8/81.

McIntosh, Robert William Valentine, late of 168 Grand Promenade, Doubleview, Hospital Orderly, died 17/8/81.

Marshall, Norma Josephine Lois, late of 26 Davis Road, Attadale, Home Duties, died 22/6/81.

Martin, Percy Charles, (Martin, Richard), late of 12B Grant Street, Narrogin, Retired Farmer, died 8/7/81.

O'Grady, William John, late of Christos Nursing Home, Station Street, Wembley, Retired Shopkeeper, died 4/8/81.

Parker, Howard Careal, late of Flat 2, 55 Deanmore Road, Scarborough, Retired Maintenance Engineer, died 27/7/81.

Patching, Stanley, late of Sunset Hospital, Beatrice Road, Dalkeith, Retired P.M.G. Linesman, died 29/7/81.

Perry, Edward Alfred, late of Sunset Hospital, Beatrice Road, Dalkeith, Retired Plumber, died 22/8/81.

Reeves, John Julius, late of 4 Lochee Street, Mosman Park, Technician—Telecom Australia, died 7/8/81.

Stout, Arthur Edward, late of 85 Atkinson Street, Collie, Retired Railway Employee, died 28/6/81.

Dated this 31st day of August, 1981.

P. W. MCGINNITY,  
Public Trustee,  
565 Hay Street, Perth.

#### PUBLIC TRUSTEE ACT 1941-1979.

NOTICE is hereby given that pursuant to section 14 of the Public Trustee Act 1941-1979 the Public Trustee has elected to administer the estates of the under-mentioned deceased persons.

Dated at Perth the 31st day of August, 1981.

P. W. MCGINNITY,  
Public Trustee,  
565 Hay Street, Perth.

Name of Deceased; Occupation; Address; Date of Death; Date Election filed.

Lawrie, William McDonald; Labourer; Parkerville; 28th or 29th March, 1981; 21/8/81.

Fleming, Gary James; Crane Driver; Lynwood; 19/6/81; 21/8/81.

Wheatley, Olive Mary; Widow; Manjimup; 17/5/81; 21/8/81.

Knowles, Edward Joshua; Retired Security Officer; Victoria Park; 18/7/81; 21/8/81.

Hawke, Frederick William; Retired Automotive Electrician; Inglewood; 19/7/81; 21/8/81.

Douglas, Francis Beryl; Married Woman; Dalkeith; 19/7/81; 21/8/81.

## GOVERNMENT GAZETTE

### NOTICE TO SUBSCRIBERS

**COPY DEADLINE:** All copy for publication must be in the hands of the Government Printer by 3 p.m. on the **WEDNESDAY** before publication.

WILLIAM C. BROWN, J.P.  
Government Printer.

### RELIGIOUS EDUCATION IN THE GOVERNMENT SCHOOLS OF WESTERN AUSTRALIA JULY 1977

Chairman Mr. W. E. Nott, S.M.

#### Prices—

Counter Sales—\$1.90

Mailed W.A.—\$2.80

Mailed Interstate—\$2.90

### REPORT, PLAN AND ATLAS FOR THE METROPOLITAN REGION, PERTH AND FREMANTLE, 1955

(Stephenson-Hepburn)

#### Prices—

Counter Sales—\$10.50

Mailed Local—\$12.10

Mailed Country—\$13.00

Mailed Interstate—\$15.80

### NOTICE.

**INCREASE DUE TO INCREASED POSTAL  
CHARGES APPLICABLE FROM  
14 July, 1981.**

**STANDING ORDER SUBSCRIPTION SERVICE**

(Price quoted includes postage)

Western Australian Statutes—Per Annum.

	Local (W.A.)	Interstate and Overseas (all states)
	\$	\$
Loose Statutes (\$6.50) ....	10.50	13.00
Bound Statutes (\$8.00) ....	12.00	14.50
Loose and Bound (\$14.50)	22.50	27.00

**Sessional Bills—\$20.00 Australia Wide.**

**REPORT OF THE SELECT COMMITTEE  
APPOINTED BY THE LEGISLATIVE  
COUNCIL TO INQUIRE INTO AND REPORT  
UPON THE**

**CURRENT POSITION OF NATIONAL  
PARKS WITHIN THE STATE**

Presented by the Hon. A. A. Lewis, M.L.C.,  
27th November, 1979.

**Prices—**

Counter Sales—\$0.50.  
Mailed (within Aust.)—\$1.00.

**FLORA OF  
WESTERN AUSTRALIA**

**Vol. 1, Part 1 (only)**

**By C. A. Gardner.**

**Prices—**

Counter Sales—\$4.50  
Mailed Local—\$6.00  
Mailed Country—\$6.80  
Mailed Interstate—\$7.00

**SUBSCRIPTION CHARGES**

**GOVERNMENT GAZETTE**

Counter Sales, per copy—\$0.60  
Annual Subscription (Excluding  
Extraordinary Copies) Including  
Postage (Surface Mail)—\$67.00  
per annum

**INDUSTRIAL GAZETTE**

Counter Sales—per copy—\$1.70  
Annual Subscription, Including Postage  
(Surface Mail)—\$35.00 per annum

**HANSARD**

Counter Sales, per copy—\$1.50  
Annual Subscription, Including Postage  
(Surface Mail)—\$40.00

**Report of Government Secondary  
Schools Discipline Committee**

**DISCIPLINE IN  
SECONDARY SCHOOLS  
IN WESTERN AUSTRALIA  
1972**

**Prices—**

Counter Sales—\$1.00  
Mailed Local—\$2.50  
Mailed Interstate—\$3.30  
Mailed Country—\$4.50

**REPORT OF THE ROYAL  
COMMISSION INTO  
"ABORIGINAL AFFAIRS" 1974**

(Commissioner Hon. Judge Lyn C. Furnell, Q.C.)

**Prices—**

Counter Sales—\$5.00  
Mailed Local—\$6.50  
Mailed Country—\$7.30  
Mailed Interstate—\$8.50

**REPORT OF THE  
ROYAL COMMISSION INTO  
AIRLINE SERVICES IN W.A. 1975**  
(Commissioner Hon. Sir Reginald R. Sholl)

**Prices—**

Counter Sales—\$5.00  
Mailed Local—\$6.50  
Mailed Country—\$7.30  
Mailed Interstate—\$8.50

**COMMITTEE OF INQUIRY  
INTO  
RATES AND TAXES  
ATTACHED TO LAND VALUATION,  
REPORT 1975**

(Mr. Gerald Keall, Chairman)

**Prices—**

Counter Sales—\$2.30  
Mailed Local—\$3.30  
Mailed Country—\$4.30  
Mailed Interstate—\$5.40

**POST SECONDARY EDUCATION  
IN  
WESTERN AUSTRALIA  
REPORT 1976**

Chairman—Professor P. H. Partridge

**Prices—**

Counter Sales—\$3.00

**Mailed—**

Mailed W.A.—\$3.90  
Mailed Interstate—\$4.00

**REPORT ON THE INQUIRY INTO  
THE BUILDING INDUSTRY OF  
WESTERN AUSTRALIA, 1973-74.**

(Enquirer, Charles Howard Smith, Q.C.)

**Prices—**

Counter Sales—\$1.00  
Mailed W.A.—\$1.90  
Mailed Eastern States—\$2.00

NOVEMBER, 1980.

Chairman—Dr. R. L. VICKERY  
**REPORT BY COMMITTEE OF INQUIRY**  
 INTO  
**TEACHER EDUCATION,**

Prices:—

Counter Sales—\$2.50.  
 Mailed Local—\$3.40.  
 Mailed Interstate—\$3.50.

---

**Report of an Analytical Study of the proposed Corridor Plan for Perth and possible alternate approach to a regional plan for the Metropolitan area, 4th August 1971, to 31st Jan., 1972 by Paul Ritter**

Prices—

Counter Sales—\$5.00  
 Mailed Local—\$5.90  
 Mailed Interstate—\$6.00

---

**SPECIAL NOTICE**

**GOVERNMENT GAZETTE ADVERTISING CHARGES**

Deceased Estate Notices, per Estate—\$5.00  
 Real Estate and Business Agents and Brokers Licences, etc., Per Notice—\$10.00  
 All Other Notices per Column Centimetre—\$1.00  
 \$5.00—Minimum Charge

---

**THE NATURAL FEATURES OF ROTTNEST ISLAND**

Collated by G. R. W. Meadly M.Sc.

Prices—

Counter Sales—\$1.80  
 Mailed Australia Wide—\$2.40

---

Available only from Harbour and Light Department, 6 Short Street, Fremantle. Phone 335 1211.—

Navigable Waters Regulations, 1958.  
 Regulations for Preventing Collisions at Sea.  
 Regulations for the Examination of Applicants for Masters, Mates, Coxswain, Engineers, Marine Motor Engine Drivers and Marine Surveyors.

**SUBSCRIPTION CHARGES**

**GOVERNMENT GAZETTE**

Counter Sales, per copy—\$0.60  
 Annual Subscription (Excluding Extraordinary Copies) Including Postage (Surface Mail)—\$67.00 per annum

**INDUSTRIAL GAZETTE**

Counter Sales—per copy—\$1.70  
 Annual Subscription, Including Postage (Surface Mail)—\$35.00 per annum

**HANSARD**

Counter Sales, per copy—\$1.50  
 Annual Subscription, Including Postage (Surface Mail)—\$40.00

---

**REPORT ON COMMITTEE OF INQUIRY INTO RESIDENTIAL CHILD CARE, SEPTEMBER, 1976**  
 CHAIRMAN—BERYL GRANT

Prices—

Counter Sales—\$2.50  
 Mailed Local—\$4.00  
 Mailed Country—\$4.80  
 Mailed Interstate—\$6.00

---

**REPORT OF THE ROYAL COMMISSION "FREMANTLE PRISON" 1973.**

(Commissioner, His Honour Robert E. Jones.)

Prices—

Counter Sales—\$1.50  
 Mailed Local—\$3.00  
 Mailed Country—\$3.80  
 Mailed Eastern States—\$5.00

---

**PRICE OF SUBSCRIPTIONS FOR—**

**Government Gazette—**

Annual Subscription—\$67.00  
 Counter Sales, Single Copies—\$0.60

**Hansard (Parliamentary Debates)—**

Annual Subscription—\$40.00  
 Counter Sales, Single Copies—\$1.50

**Western Australian Industrial Gazette—**

Annual Subscription—\$35.00  
 Counter Sales, Single Copies—\$1.70

**PROPOSED  
INDUSTRIAL RELATIONS ACT**

AS PREPARED BY  
E. R. KELLY, ESQ.,  
Senior Commissioner  
W.A. Industrial Commission  
September 21, 1978.

Counter Sales—\$1.50.  
Mailed W.A.—\$2.40  
Mailed Interstate—\$2.50

**COMMISSION OF THE PEACE FOR  
W.A.—JULY, 1980**

Prices—

Counter Sales—\$1.30  
Mailed—Local \$2.20  
Country and Interstate—\$2.30

**REPORT OF LAVERTON  
ROYAL COMMISSION 1975-76**

Chairman Gresley D. Clarkson.

Prices—

Counter Sales—\$2.00  
Mailed Local—\$3.50  
Mailed Country—\$4.30  
Mailed Interstate—\$5.50

**DIGEST OF  
WESTERN AUSTRALIAN  
ARBITRATION REPORTS**

Volumes 1 to 14—1901-1920

Prices—

Counter Sales—\$5.00  
Mailed Local—\$5.90  
Mailed Interstate—\$6.00

**DIGEST OF  
WESTERN AUSTRALIAN  
INDUSTRIAL GAZETTES**

Volumes 1 to 10—1921-1930

Prices—

Counter Sales—\$5.00  
Mailed Local—\$5.90  
Mailed Interstate—\$6.00

**ELECTORAL ACT ENQUIRY  
REPORT OF HIS HONOUR A. E. KAY  
TO THE**

**HONOURABLE D. H. O'NEIL, M.L.A.  
CHIEF SECRETARY**

October 1978.

Counter Sales—\$2.00  
Mailed W.A.—\$2.90  
Mailed Interstate—\$3.00

**THE PARLIAMENT OF W.A. DIGEST  
1979 (No. 7)**

(Compiled in the Offices of the Clerk of the  
Legislative Assembly)  
(Synopsis of Legislation)

Price—\$0.90  
Mailed—\$1.50

**NOTICE.**

Subscriptions are required to commence and terminate with a quarter.

The *Government Gazette* is published on Friday in each week, unless interfered with by public holidays or other unforeseen circumstances.

**SUBSCRIPTIONS:**—The subscriptions to the *Government Gazette* are as follows:—Annual subscriptions, \$67; nine months, \$55; six months, \$35; three months, \$20; single copies (current year), \$0.60; single copies (previous years, up to 10 years), \$0.80; over 10 years, \$1.

**REPORT OF THE HONORARY  
ROYAL COMMISSION OF  
INQUIRY INTO THE  
TREATMENT OF ALCOHOL  
AND DRUG DEPENDENTS IN  
WESTERN AUSTRALIA, 1973**

(Hon. R. J. L. Williams, M. L. C., Chairman)

Prices—

Counter Sales—\$1.50  
Mailed—\$2.10

**SPECIAL NOTICE**

FROM 1st JULY, 1980, TREASURY APPROVED  
INCREASE IN CHARGES.

**GOVERNMENT GAZETTE ADVERTISING  
CHARGES**

Deceased Estate Notices, per Estate—  
\$5.00

Real Estate and Business Agents and  
Brokers Licences, etc.,  
Per Notice—\$10.00

All Other Notices  
per Column Centimetre—\$1.00

\$5.00—Minimum Charge

**CURRENT RELEASE**

**HEALTH ACT No. 34 of 1911-1979**  
(9th Reprint Approved 14/5/81)  
Includes Amendment Act No. 72 of 1979

—NOW AVAILABLE—

Counter Sales—\$6.50  
Mailed Local—\$8.00  
Mailed Country—\$9.00  
Mailed Interstate—\$10.00

**NOTICE****TRADING HOURS**

**WEMBLEY—HEAD OFFICE**  
(Parliamentary Papers)

GOVERNMENT PRINTER'S  
PUBLICATION SALES OFFICE  
SALVADO ROAD, WEMBLEY

Phone 381 3111 Extensions 374 and 376

8.00 a.m. to 4.30 p.m.  
(Continually Mon. to Fri.)

**PERTH OFFICE**

**GOVERNMENT PUBLICATIONS CENTRE**  
(Parliamentary Papers)

Ground Floor Superannuation Bldg.  
32 St. George's Terrace, Perth 6000  
Telephone 325 0231 Ext. 375  
8.15 a.m. to 4.25 p.m.  
(Continually Mon. to Fri.)

**REPORT OF THE EGG INDUSTRY**  
**ENQUIRY OF W.A., 1973.**

(Neil D. McDonald Enquirer.)

Prices—

Counter Sales—\$3.50  
Mailed Local—\$5.00  
Mailed Country—\$5.80  
Mailed Interstate—\$7.00

**CONTENTS.**

**REGULATIONS, BY-LAWS, RULES,  
DETERMINATIONS, ORDERS.**

	Page
Dairy Industry Amendment Regulations .....	3891-8
Dog Act—By-laws—	
City of South Perth .....	3880-1
Shire of Tammin .....	3886-8
Enzootic Diseases Regulations Notice .....	3891
Hire Purchase (Credit Providers Licensing) Amendment Regulations .....	3890
Limited Coast-Trade Vessels Amendment Regulations (No. 2) .....	3859-60
Local Government Act—By-laws—	
City of Fremantle—Stalls .....	3877-9
City of Fremantle—Movable or Temporary Stalls .....	3879
City of Perth—No. 64 .....	3879-80
Town of Kalgoorlie—Standing Orders .....	3881
Shire of Collic—Motels .....	3881
Shire of Esperance—Management and Control of Centre .....	3882-4
Shire of Greenough—Signs, Hoardings and Billposting .....	3885
Shire of Waroona—Control and Management of Halls .....	3888-9
Local Government Act—Town of Kalgoorlie (Specified Area) Order .....	3876
Navigable Waters Amendment Regulations (No. 5) .....	3861-2
Pig Industry Compensation Amendment Regulations .....	3891
Ports and Harbours Amendment Regulations (No. 6) .....	3859
Prevention of Collisions at Sea Amendment Regulations .....	3859
Road Traffic Code Amendment (No. 3) .....	3833
Shops (Exempted Goods) Amendment Regulations .....	3889
Vehicle Standards Amendment Regulations (No. 5) .....	3833
Western Australian Marine Act (Examinations) Amend- ment Regulations (No. 2) .....	3860-1

**GENERAL CONTENTS.**

	Page
Agriculture, Department of .....	3891-8
Audit Act .....	3831
Bush Fires Act .....	3847-50
Chief Secretary's Department .....	3831
Commission .....	3825
Commissioners for Declarations .....	3831
Companies Act .....	3914-5
Deceased Persons' Estates .....	3915-6
Factories and Shops .....	3889
Fisheries .....	3833-4
Forestry .....	3847
Harbour and Light Department .....	3858
Health Department .....	3832
Inquiry Agents Licensing Act .....	3831
Labour, Department of .....	3828, 3889-90
Lands Department .....	3826-7, 3828-30, 3834-46, 3862-3
Land Drainage Act .....	3857-8
Local Government Department .....	3864
Municipal By-laws .....	3876-89
Main Roads .....	3863, 3901
Metropolitan Region Planning .....	3854-5
Metropolitan Water Supply, etc. .....	3830-1
Mines Department .....	3902-13
Municipalities .....	3864-74
Navigable Waters Regulations .....	3858
Notices of Intention to Resume Land .....	3862-3
Orders in Council .....	3828-31
Premier's Department .....	3831
Proclamations .....	3826-8
Public and Bank Holidays Act .....	3828
Public Trustee .....	3915-6
Public Works Department .....	3830, 3856
Registrar General .....	3902
Rights in Water and Irrigation Act .....	3857
Road Traffic Act .....	3833
Tender Board .....	3898-901
Tenders Accepted .....	3900-1
Tenders for Government Printing .....	3901
Tenders Invited .....	3898-9
Town Planning .....	3850-4
Treasury .....	3831
Trustees Act .....	3915-6
Water Boards Act .....	3864