



Western Australia

## **Road Traffic (Vehicle Standards) Rules 2002**

Compare between:

[27 Jul 2004, 00-c0-03] and [01 Jan 2006, 00-d0-06]



Western Australia

Road Traffic Act 1974

## **Road Traffic (Vehicle Standards) Rules 2002**

### **Part 1 — Preliminary**

**1. Citation**

These regulations may be cited as the *Road Traffic (Vehicle Standards) Rules 2002*.

*[Rule 1 amended in Gazette 3 Jan 2003 p. 3.]*

**2. Commencement**

These rules come into operation on 1 November 2002.

*[Rule 2 amended in Gazette 3 Jan 2003 p. 3.]*

**3. Interpretation**

- (1) These rules are to be read together with the *Road Traffic (Vehicle Standards) Regulations 2002* as if they formed a single written law.
- (2) The Glossary at the end of the *Road Traffic (Vehicle Standards) Regulations 2002* defines or affects the meaning of some words and expressions used in these rules.

## **Part 2 — Application of the Vehicle Standards**

### **4. Application to vehicles and combinations**

The Vehicle Standards apply to motor vehicles, trailers and combinations.

### **5. Non-application of the Vehicle Standards — exemption under other laws**

- (1) A provision of the Vehicle Standards does not apply to a vehicle if the vehicle is exempt from —
  - (a) the provision under another law of this State; or
  - (b) the corresponding provision of the law of another State, a Territory or the Commonwealth.
- (2) However, the vehicle is exempt only if all conditions of the exemption (if any) are being complied with.

### **6. Non-application of the Vehicle Standards — inconsistent ADR requirements**

A provision of Parts 5 to 13 of the Vehicle Standards does not apply to a vehicle if —

- (a) the provision is inconsistent with a requirement of a second or third edition ADR applying to the vehicle; and
- (b) the vehicle complies with the requirement.

### **7. Non-application of the Vehicle Standards — approvals under *Motor Vehicle Standards Act 1989* (Cwlth)**

A provision of Parts 5 to 13 of the Vehicle Standards does not apply to a vehicle if —

- (a) the vehicle does not comply with a requirement of an ADR applying to the vehicle;
- (b) the provision of the Vehicle Standards corresponds to the requirement of the ADR;

- (c) despite the non-compliance, approval has been given, under section 10A(2) or (3) of the *Motor Vehicle Standards Act 1989* of the Commonwealth, to place identification plates on vehicles of that type; and
- (d) the vehicle complies with the approval conditions (if any).

## Part 3 — Australian Design Rules

### Division 1 — Interpretation

**8. What is an ADR**

An “**ADR**” (which stands for “Australian Design Rule”) is a national standard.

**9. What is a national standard**

A “**national standard**” is a national standard under the *Motor Vehicle Standards Act 1989* of the Commonwealth.

**10. References to national standards**

Unless the contrary intention appears, a reference in the Vehicle Standards to a national standard is a reference to the national standard as in force on the day on which the Vehicle Standards come into operation.

**11. What is a second edition ADR**

A “**second edition ADR**” is a national standard incorporated in the document described as the Australian Design Rules for Motor Vehicle Safety, Second Edition originally published by the then Commonwealth Department of Transport.

**12. What is a third edition ADR**

A “**third edition ADR**” is a national standard incorporated in the document described as the Australian Design Rules for Motor Vehicles and Trailers, Third Edition published by the Federal Office of Road Safety of the Commonwealth Department of Transport and Regional Development.

## **Division 2 — Compliance with ADRs**

### **13. Compliance with second edition ADRs**

- (1) If a second edition ADR recommends that the ADR should apply to the design and construction of a vehicle, the vehicle must comply with the ADR.
- (2) If a second edition ADR contains a requirement for a type of equipment fitted to a vehicle built on or after a stated time, any equipment of the same type fitted to the vehicle after it is built must comply with —
  - (a) the requirement as in force when the vehicle was built; or
  - (b) if the requirement is amended after the vehicle is built and before the equipment is fitted — the requirement as in force —
    - (i) when the vehicle was built;
    - (ii) when the equipment was fitted; or
    - (iii) at any time between when the vehicle was built and the equipment was fitted.
- (3) However, a vehicle, or equipment fitted to a vehicle, need not comply with a recommendation or requirement of a second edition ADR if —
  - (a) the recommendation or requirement is replaced by, or is inconsistent with, a requirement of a third edition ADR applying to the vehicle or equipment; and
  - (b) the vehicle or equipment complies with the requirement of the third edition ADR.
- (4) If a second edition ADR allows a vehicle built on or after a stated time to be fitted with equipment, a vehicle built before the time may also be fitted with the equipment.

### **14. Compliance with third edition ADRs**

- (1) If a third edition ADR applies to the design and construction of a vehicle, the vehicle must comply with the ADR.

- (2) If a third edition ADR contains a requirement for a type of equipment fitted to a vehicle built on or after a stated time, any equipment of the same type fitted to the vehicle after it is built must comply with —
- (a) the requirement as in force when the vehicle was built; or
  - (b) if the requirement is amended after the vehicle is built and before the equipment is fitted — the requirement as in force —
    - (i) when the vehicle was built;
    - (ii) when the equipment was fitted; or
    - (iii) at any time between when the vehicle was built and the equipment was fitted.
- (3) However, a vehicle, or equipment fitted to a vehicle, need not comply with a requirement of a third edition ADR if —
- (a) the requirement is replaced by, or is inconsistent with, a requirement of a later version of the ADR applying to the vehicle or equipment; and
  - (b) the vehicle or equipment complies with the requirement of the later version.
- (4) If a third edition ADR allows a vehicle built on or after a stated time to be fitted with equipment, a vehicle built before the time may also be fitted with the equipment.

**15. Exception to compliance with ADRs — vehicles that are not road vehicles**

A vehicle need not comply with an ADR applied by rule 13(1) or 14(1) if a determination or declaration under section 5B of the *Motor Vehicle Standards Act 1989* of the Commonwealth provides that the vehicle is not a road vehicle for that Act.



**16. Exception to compliance with ADRs — *Motor Vehicle Standards Act 1989* (Cwlth)**

- (1) A vehicle need not comply with an ADR applied by rule 13(1) or 14(1) if —
  - (a) despite non-compliance with the ADR, approval has been given, under section 10A(2) or (3) of the *Motor Vehicle Standards Act 1989* of the Commonwealth, to place identification plates on vehicles of that type; and
  - (b) the vehicle complies with the approval conditions (if any).
- (2) A vehicle need not comply with an ADR applied by rule 13(1) or 14(1) if —
  - (a) the vehicle may be supplied to the market under section 14A(1) of the *Motor Vehicle Standards Act 1989* of the Commonwealth; and
  - (b) for a vehicle for which an approval has been given under that section — the vehicle complies with the approval conditions (if any).
- (3) A vehicle need not comply with an ADR applied by rule 13(1) or 14(1) if —
  - (a) the vehicle may be used in transport in Australia under section 15(2) of the *Motor Vehicle Standards Act 1989* of the Commonwealth; and
  - (b) for a vehicle for which an approval has been given under that section — the vehicle complies with the approval conditions (if any).

**17. Partial exception to compliance with ADRs - personally imported vehicles**

- (1) In this rule —

**“personally imported vehicle”** means a vehicle built after 1968 that is imported into Australia by a person who —

  - (a) owned and used the vehicle for a continuous period of at least 12 months before it was imported into Australia;

- (b) when the vehicle was imported into Australia, was —
    - (i) an Australian citizen or permanent resident or a person who had applied to become an Australian citizen or permanent resident; and
    - (ii) old enough to hold a licence or permit to drive the vehicle;and
  - (c) within the previous year, had not imported into Australia another vehicle owned by the person.
- (2) A personally imported vehicle must be fitted with —
- (a) seat belts that are as effective as seat belts that meet an Australian Standard or British Standard for seat belts as in force when this rule commenced;
  - (b) seat belt anchorages that meet the number and location requirements of second or third edition ADR 5;
  - (c) child restraint anchorages that meet the number, location, accessibility, thread size and form requirements of second edition ADR 34 or third edition ADR 5 or 34; and
  - (d) head restraints that meet the number, location and size requirements of second or third edition ADR 22.
- (3) However, a personally imported vehicle need only meet the requirements of an ADR mentioned in subrule (2) if the ADR recommends that it applies or should apply to a vehicle of the same type.
- (4) A personally imported vehicle need not otherwise comply with an ADR applied by rule 13(1) or 14(1).

*[Rule 17 amended in Gazette 27 Jul 2004 p. 3083.]*

## Part 4 — Adopted standards

### 18. What is an adopted standard

An “*adopted standard*” is a standard, except a national standard, that is applied, adopted or incorporated by the Vehicle Standards.

### 19. Reference to adopted standards

Unless the contrary intention appears, a reference in a rule or subrule to an adopted standard is a reference to the standard as in force when the rule or subrule commenced.

### 20. Exception to compliance with adopted standards

A vehicle need not comply with an adopted standard if —

- (a) the standard is replaced by, or is inconsistent with, a later version of the standard; and
- (b) the vehicle complies with the later version of the standard.

## **Part 5 — General safety requirements**

### **Division 1 — All vehicles**

#### **21. Steering**

- (1) A motor vehicle with a GVM over 4.5 t must have a right-hand drive.
- (2) A motor vehicle with a GVM not over 4.5 t must have a right-hand drive unless —
  - (a) the vehicle is more than 30 years old; or
  - (b) the vehicle —
    - (i) is more than 15 years old, but not more than 30 years old; and
    - (ii) is used solely for personal use.
- (3) A motor vehicle has a right-hand drive if the centre of at least one steering control of the vehicle is to the right of, or in line with, the centre of the vehicle.
- (4) A component of the steering system of a motor vehicle that is essential for effective steering of the vehicle must be built to transmit energy by mechanical means only.
- (5) Failure of a non-mechanical component of the steering system must not prevent effective steering of the vehicle.
- (6) This regulation does not apply to a vehicle built or used mainly for a purpose other than the transport of goods or people by road.

*[Rule 21 amended in Gazette 3 Jan 2003 p. 3-4.]*

#### **22. Turning ability**

- (1) A motor vehicle must be able to turn in a circle not over 25 m in diameter, measured by the outer edge of the tyre track at ground level.

- (2) The vehicle must be able to comply with subrule (1) whether it turns to the left or to the right.

**23. Ability to travel backwards and forwards**

A motor vehicle with an unloaded mass over 450 kg must be able to be driven both backwards and forwards when the driver is in the normal driving position.

**24. Protrusions**

- (1) An object fitted to a vehicle must be designed, built and fitted to the vehicle in a way that minimises the likelihood of injury to a person making contact with the vehicle.
- (2) However, subrule (1) does not apply to an object fitted to a vehicle if —
- (a) the vehicle was designed before 1965 and the object was part of the design of the vehicle; or
  - (b) the object was fitted to the vehicle before 1965 in accordance with the law of the place where the object was fitted.

**25. Driver's view and vehicle controls**

A motor vehicle must be built —

- (a) to allow the driver a view of the road and of traffic to the front and sides of the vehicle so the driver can drive the vehicle safely; and
- (b) with its controls located so the driver can drive the vehicle safely.

**26. Seating**

A seat for a driver or passenger in a vehicle must be securely attached to the vehicle.

**27. Mudguards and spray suppression**

- (1) A vehicle must have firmly fitted a mudguard for each wheel or for adjacent wheels.
- (2) However, subrule (1) does not apply to a vehicle if —
  - (a) the construction or use of the vehicle makes the fitting of mudguards unnecessary or impracticable; or
  - (b) the body or part of the body of the vehicle acts as a mudguard.
- (3) A mudguard fitted to a vehicle with a GVM over 4.5 t must, when the wheels of the vehicle are in position to move straight ahead —
  - (a) reduce the danger of a person contacting the moving wheels; and
  - (b) for the rear wheels —
    - (i) cover the overall tyre width of the wheel or wheels to which it is fitted; and
    - (ii) be fitted so the height above ground level of the lowest edge of the rear of the mudguard is not over one-third of the horizontal distance between the edge and the centre of the rearmost axle.
- (4) However, a mudguard may be up to —
  - (a) 230 mm above ground level; or
  - (b) on a vehicle built to be used off road — 300 mm above ground level.
- (5) The outside of a rear mudguard, except a mudflap, of a vehicle that can be seen from the rear of the vehicle must be coloured white or silver if the vehicle —
  - (a) is at least 2.2 m wide;
  - (b) has a body the vertical measurement of which is under 300 mm at the rear, measured from the lowest point of the body above ground level to the highest point; and

(c) is not fitted with rear marking plates in accordance with rule 113.

(6) For subrule (5)(a), the width of a vehicle is measured disregarding any anti-skid device mounted on wheels, central tyre inflation systems, lights, mirrors, reflectors, signalling devices and tyre pressure gauges.

**28. Horns, alarms etc.**

(1) A motor vehicle must be fitted with at least one horn or other device that can give sufficient audible warning to other road users of the approach or position of the vehicle.

(2) A motor vehicle must not be fitted with a device that can make a sound like the sound of a siren, bell, exhaust whistle, compression whistle or repeater horn.

(3) However, subrule (2) does not apply to —

- (a) an emergency vehicle;
- (b) a transport enforcement vehicle;
- (c) an Australian Protective Service vehicle;
- (d) an Australian Customs Service vehicle;
- (e) an Airservices Australia vehicle;
- (f) a vehicle at least 25 years old that is fitted as an emergency vehicle if —
  - (i) the vehicle is used for exhibition purposes; or
  - (ii) it is part of a collection of former emergency vehicles;

or

(g) an anti-theft alarm if the alarm cannot be operated while the vehicle's ignition is on.

(4) Also, a motor vehicle may be fitted with a device that emits a regular, intermittent sound while the vehicle is reversing or in reverse gear.

- (5) The device must not be louder than is necessary so the driver, and a person near the vehicle, can hear the device when it is operating.
- (6) In this rule —  
**“repeater horn”** means a device that makes a sound alternating between different tones or frequencies on a regular time cycle.  
*[Rule 28 amended in Gazette 3 Jan 2003 p. 4.]*

**29. Rear vision mirrors**

- (1) A rear vision mirror or mirrors must be fitted to a motor vehicle as required by this rule so that a driver of the vehicle can clearly see by reflection the road behind the vehicle and any following or overtaking vehicle.
- (2) At least one rear vision mirror must be fitted to —
- (a) a car;
  - (b) a motor trike with 2 front wheels; and
  - (c) a motor bike, or motor trike with one front wheel, built before July 1975.
- (3) At least one rear vision mirror must be fitted to each side of —
- (a) a motor vehicle with a GVM over 3.5 t; and
  - (b) a motor bike, or motor trike with one front wheel, built after June 1975.
- (4) A motor vehicle with a GVM not over 3.5 t (except a motor vehicle mentioned in subrule (2) or (3)) must be fitted with —
- (a) at least one rear vision mirror on the right side of the vehicle; and
  - (b) at least one rear vision mirror on the left side of the vehicle or inside the vehicle.
- (5) A rear vision mirror fitted to a motor vehicle with a GVM over 3.5 t must not project over 150 mm beyond the widest part



(excluding lights, signalling devices and reflectors) of the vehicle.

- (6) However, the rear vision mirror may project not over 230 mm beyond the widest part of the vehicle if it can fold to project not over 150 mm beyond the widest part.

**30. Rear vision mirrors — surfaces**

- (1) A rear vision mirror required to be fitted to the side of a motor vehicle with a GVM over 3.5 t must have a reflecting surface of at least 150 cm<sup>2</sup>.
- (2) A rear vision mirror required to be fitted to the right side of a motor vehicle with a GVM over 3.5 t must have a flat reflecting surface if —
- (a) the motor vehicle has only one steering control; and
  - (b) the centre of the steering control is to the right of, or in line with, the centre of the motor vehicle.
- (3) The reflecting surface of a rear vision mirror that is required to be fitted to a motor bike or moped must —
- (a) each be of the same curvature; and
  - (b) if convex, be part of a notional sphere with a radius of at least 1.2 m.

**31. Additional rear vision mirrors**

A motor vehicle may be fitted with additional rear vision mirrors or mirror surfaces that are flat or convex or a combination of flat and convex surfaces.

**32. Automatic transmission**

- (1) A motor vehicle fitted with an automatic transmission must have an engine starter mechanism that cannot operate when the transmission control is in a position to drive the vehicle.

- (2) A vehicle built after 1975 that is fitted with an automatic transmission must have an indicator in the driver's compartment showing the transmission control position.
- (3) Subrules (1) and (2) do not apply to a motor vehicle with less than 4 wheels.

**33. Diesel engines**

A motor vehicle propelled by a compression ignition engine (commonly known as a diesel engine) must be fitted with a device preventing the engine from being started accidentally or inadvertently.

**34. Bonnet securing devices**

- (1) A motor vehicle with a moveable body panel forward of the windscreen that covers an engine or luggage storage or battery compartment, must have a device to secure the panel.
- (2) However, if the panel opens from the front in a way that partly or completely obstructs the driver's forward view through the windscreen, the panel must have primary and secondary devices to secure the panel.

**35. Electrical wiring, connections and installations**

- (1) The wiring of electrical equipment of a vehicle, except the high tension ignition wiring, must —
  - (a) be supported at intervals of not over 600 mm, unless the vehicle is a pole-type trailer with a pole with an adjustable length, or an extendible trailer;
  - (b) be insulated at each of its joints;
  - (c) be located where it cannot —
    - (i) become overheated;
    - (ii) contact moving parts; or
    - (iii) come near enough to the fuel system to be a fire hazard;

and

- (d) be protected from chafing.
- (2) The electrical connectors between motor vehicles and trailers, for operation of the vehicle lights required by the Vehicle Standards, must comply with Australian Standard AS 2513-1982 *Electrical Connections for Trailer Vehicles*.
- (3) A trailer must be equipped with an electrical conductor, independent of the trailer coupling, that provides a return path between the electrical circuits of the trailer and towing vehicle.
- (4) The electrical wiring, connections and installations of a semi-trailer, dog trailer or converter dolly used in a road train over 19 m long after June 1998 must comply with third edition ADR 63, whether or not it was built before the date stated in the ADR for vehicles of that type.

**36. Television receivers and visual display units**

- (1) A television receiver or visual display unit must not be installed in a vehicle so any part of the image on the screen is visible to the driver from the normal driving position.
- (2) However, subrule (1) does not apply to —
  - (a) a television receiver or visual display unit that cannot be operated when the vehicle is moving; or
  - (b) a driver's aid in any vehicle or a destination sign in a bus.
- (3) A television receiver, or visual display unit, and its associated equipment in a vehicle must be securely mounted in a position that —
  - (a) does not obscure the driver's view of the road; and
  - (b) does not impede the movement of a person in the vehicle.

**37. Windscreens and windows**

- (1) Transparent material used in a windscreen, window or an interior partition, of a motor vehicle must be of approved material if —
- (a) the vehicle was built after June 1953; or
  - (b) the material was first fitted to the vehicle after June 1953.

- (2) In this rule —

**“approved material”** means material with the same characteristics as material mentioned in any of the following standards —

- (a) Australian Standard AS R1-1965 *Safety Glass for Land Transport*;
- (b) Australian Standard AS R1-1968 *Safety Glass for Land Transport*;
- (c) Australian Standard AS 2080-1977 *Safety Glass for Vehicles*;
- (d) British Standard BS 857:1967 *Specification for Safety Glass for Land Transport*;
- (e) British Standard BS 5282:1975 *Road Vehicle Safety Glass*;
- (f) British Standard BS AU178:1980 *Road Vehicle Safety Glass*;
- (g) Japanese Industrial Standard JIS R 3211-1979 *Safety Glasses for Road Vehicles*;
- (h) American National Standard ANSI Z26.1-1980 *Safety Code for Safety Glazing Materials for Glazing Motor Vehicles Operating on Land Highway*;

**“transparent material”** does not include any coating added to the windscreen, window or partition after its manufacture.

**38. Window tinting**

- (1) Glazing used in a windscreen of a motor vehicle must have a luminous transmittance of at least —
  - (a) for a motor vehicle built after 1971 — 75%; or
  - (b) for another motor vehicle — 70%.
- (2) Windscreen glazing of a motor vehicle must not be coated in a way that reduces its luminous transmittance.
- (3) However, subrules (1) and (2) do not apply to the greater of the following areas of a windscreen —
  - (a) the area above the highest point of the windscreen that is swept by a windscreen wiper;
  - (b) the upper 10% of the windscreen.
- (4) Glazing used in a window or interior partition of a motor vehicle must have a luminous transmittance of at least 70%.
- (5) Glazing in a window other than the windscreen may be coated to achieve a luminous transmittance of not less than 35%.
- (6) Glazing that has been coated to reduce its luminous transmittance must not have a reflectance of over 10%.
- (7) The luminous transmittance requirement in subrule (5) applies to a vehicle instead of the corresponding requirement in the relevant ADR.
- (8) In this rule —

**“glazing”** means material fitted to the front, sides, rear or interior of a vehicle, through which the driver can see the road, but does not include a coating added after manufacture of the material;

**“luminous transmittance”**, for glazing, means the amount of light that can pass through the glazing as a percentage of the amount of light that would be transmitted if the glazing were absent.

**39. Windscreen wipers and washers**

- (1) A motor vehicle with 3 or more wheels that is fitted with a windscreen must be fitted with at least one windscreen wiper unless a driver in a normal driving position can obtain an adequate view of the road ahead of the motor vehicle without looking through the windscreen.
- (2) At least one windscreen wiper fitted to the motor vehicle must —
  - (a) be able to remove moisture from the part of the windscreen in front of the driver to allow the driver an adequate view of the road ahead of the motor vehicle when the windscreen is wet;
  - (b) be able to be operated from a normal driving position;
  - (c) for a motor vehicle built after 1934 — continue to operate until the wiper is switched off; and
  - (d) for a motor vehicle built after 1959 the driving position of which is nearer one side of the vehicle than the other —
    - (i) be able to remove moisture from the part of the windscreen in front of the driver, and a corresponding part of the windscreen on the other side of the centre of the motor vehicle, to allow the driver an adequate view of the road ahead of the motor vehicle when the windscreen is wet; and
    - (ii) if the windscreen wipers are operated by engine manifold vacuum — be provided with a vacuum reservoir or pump to maintain the efficient operation of the wiper or wipers while the vehicle is in motion.
- (3) If the motor vehicle was built after 1982 and has a GVM over 4.5 t, it must also be fitted with a windscreen washer that can direct water onto the windscreen within the area swept by a windscreen wiper so the wiper can spread the water to all of the area swept by the wiper.

- (4) The windscreen washer must be able to be operated from a normal driving position.

**40. Wheels and tyres — size and capacity**

The wheels and tyres fitted to an axle of a vehicle must be of sufficient size and capacity to carry the part of the vehicle's gross mass transmitted to the ground through the axle.

**41. Pneumatic tyres generally**

A vehicle built after 1932 must be fitted with pneumatic tyres.

**42. Pneumatic tyres — carcass construction**

- (1) A vehicle with a GVM not over 4.5 t must not have pneumatic tyres of different carcass construction fitted to the same axle, but the tyres may have different cord materials and a different number of plies.
- (2) However, subrule (1) does not apply to a tyre being used in an emergency as a temporary replacement for a tyre complying with the subrule.

**43. Pneumatic tyres — size and capacity**

The size and capacity of a pneumatic tyre to be fitted to a vehicle must be decided using a cold inflation pressure that is not more than the lesser of —

- (a) the pressure recommended by the tyre manufacturer; and
- (b) a pressure of —
- (i) for a radial ply tyre — 825 kPa; or
- (ii) for another tyre — 700 kPa.

**44. Tyres — defects**

A tyre fitted to a vehicle must be free of any apparent defect that could make the vehicle unsafe.

**45. Tyres for use on vehicles with GVM over 4.5 t**

- (1) A tyre fitted to a vehicle with a GVM over 4.5 t must be suitable for road use at the lesser of —
  - (a) 100 km/h; and
  - (b) the vehicle's top speed.
- (2) This rule applies to a vehicle instead of the tyre speed category requirements in the relevant ADR.

**46. Tyres — manufacturer's rating**

- (1) This rule applies to a motor vehicle if the vehicle —
  - (a) has 4 or more wheels;
  - (b) was built after 1972; and
  - (c) has a GVM not over 4.5 t.
- (2) However, this rule does not apply to a tyre if the tyre —
  - (a) is recommended by the vehicle builder as suitable for limited use on the vehicle in special circumstances at a speed less than the speed applying to the vehicle under subrule (3); or
  - (b) is being used in an emergency as a temporary replacement for a tyre complying with this rule.
- (3) A tyre fitted to a motor vehicle must, when first manufactured, have been rated by the tyre manufacturer as suitable for road use at the lesser of —
  - (a) a speed of at least —
    - (i) for a car with special features for off-road use — 140 km/h;
    - (ii) for another car — 180 km/h; or
    - (iii) for another motor vehicle — 120 km/h;and
  - (b) the vehicle's top speed.
- (4) This rule applies to a vehicle instead of the tyre speed category requirements in the relevant ADR.



**47. Retreads**

- (1) A tyre that is retreaded before the commencement of this rule must not be used on a vehicle if —
  - (a) Australian Standard AS 1973-1976 Retreaded Pneumatic Passenger Car and Light Truck Tyre or Australian Standard AS 1973-1985 Retreaded Pneumatic Passenger and Light Truck Tyre applies to the tyre;
  - (b) the tyre was retreaded after publication of the Australian Standard; and
  - (c) the tyre was not retreaded in accordance with Australian Standard AS 1973-1976 *Retreaded Pneumatic Passenger Car and Light Truck Tyre*, Australian Standard AS 1973-1985 *Retreaded Pneumatic Passenger and Light Truck Tyre* or Australian Standard AS 1973-1993 *Pneumatic Tyres — Passenger Car, Light Truck and Truck/Bus — Retreading and Repair Processes*.
- (2) A tyre that is retreaded after the commencement of this rule must not be used on a vehicle if —
  - (a) Australian Standard AS 1973-1993 *Pneumatic Tyres — Passenger Car, Light Truck and Truck/Bus — Retreading and Repair Processes* applies to the tyre; and
  - (b) the tyre was not retreaded in accordance with the Australian Standard.

**48. Tyre tread**

- (1) A tyre on a motor vehicle must not have cleats or other gripping devices that could damage road surfaces.
- (2) Except at tread wear indicators, a tyre fitted to the vehicle must have a tread pattern at least 1.5 mm deep in a band that runs continuously —
  - (a) across —

- (i) for a vehicle with a GVM over 4.5 t — at least 75% of the tyre width that normally comes into contact with the road; or
    - (ii) for another vehicle — the tyre width that normally comes into contact with the road;
  - and
  - (b) around the whole circumference of the tyre.
- (3) A vehicle must not be fitted with a tyre that has been treated by recutting or regrooving the tread rubber, unless the tyre was —
- (a) constructed with an extra thickness of rubber designed for recutting or regrooving; and
  - (b) labelled to indicate the construction.

### **Division 2 — Additional requirements for motor bikes**

#### **49. Steering gear and handlebars**

- (1) The handlebars on a motor bike must extend at least 250 mm, but not over 450 mm, on each side of the centre line of the vehicle.
- (2) In taking a measurement for subrule (1), mirrors and lights mounted on the handlebars of the motor bike are disregarded.
- (3) The lowest part of the hand grip on the handle bars must not be higher than 380 mm above the attachment point of the handlebars to the motor bike.
- (4) Hand grips on the handle bars must be fitted symmetrically.
- (5) If a motor bike has the head stem as the steering pivot point, the horizontal distance from the midpoint between the head stem bearings to the centre of the front wheel must not be over 550 mm.

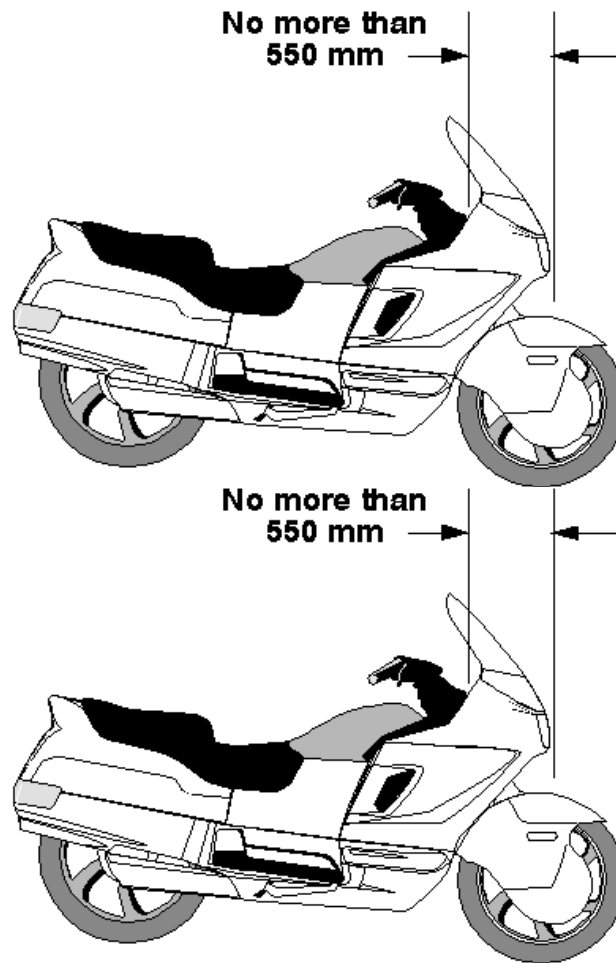

**Maximum horizontal distance from midpoint between head stem bearings of motor bike to centre of front wheel**

**50. Foot rests**

A motor bike must be fitted with foot rests for the driver and for any passenger for whom a seating position is provided.

**51. Chain guards**

- (1) If the engine power of a motor bike is transmitted to the rear wheel by a chain, the driver and any passenger must be

**Road Traffic (Vehicle Standards) Rules 2002**

**Part 5** General safety requirements

**Division 2** Additional requirements for motor bikes

**r. 51**

---

protected from the front sprocket and at least the upper part of the chain by —

- (a) the frame or equipment of the motor bike; or
  - (b) a chain guard.
- (2) A chain guard must cover the chain to a point —
- (a) at least 300 mm to the rear of the rearmost foot rest; or
  - (b) above the centre of the rear drive sprocket.

---

## Part 6 — Vehicle marking

### 52. Vehicle and engine identification numbers

- (1) In this rule —  
*“number”* includes letter.
- (2) A motor vehicle must have an individual engine identification number clearly stamped, embossed or otherwise permanently marked on it.
- (3) A motor vehicle built after 1930 must have the engine identification number on its engine block or the main component of its engine.
- (4) A vehicle must have an individual vehicle identification number clearly stamped, embossed or otherwise permanently marked on a substantial part of its frame or chassis.
- (5) A vehicle or engine identification number must be located where a person can read it easily without having to use tools to remove a part of the vehicle that would otherwise obstruct the person's view.

### 53. White or silver band on certain vehicles

- (1) This rule applies to a vehicle that —
  - (a) is at least 2.2 m wide;
  - (b) has a body with a vertical measurement under 300 mm at the rear, measured from the lowest point of the body above ground level to the highest point; and
  - (c) is not fitted with rear marking plates in accordance with rule 113.
- (2) For subrule (1)(a), the width of a vehicle is measured disregarding any anti-skid device mounted on wheels, central tyre inflation systems, lights, mirrors, reflectors, signalling devices and tyre pressure gauges.

**r. 54**

---

- (3) The vehicle must have a white or silver band at least 75 mm high across the full width of the rearmost part of the body of the vehicle.

**54.      Warning signs for combinations over 22 m long**

- (1) The following vehicles must display road train warning signs complying with this rule and rule 56 —
  - (a) a combination over 36.5 m long;
  - (b) a road train over 30 m, but not over 36.5 m, long that includes one or more dog trailers.
- (2) The following vehicles must display road train warning signs, or a long vehicle warning sign, complying with this rule and rule 56 —
  - (a) a road train over 22 m, but not over 30 m, long that includes one or more dog trailers;
  - (b) a road train over 22 m, but not over 36.5 m, long that does not include a dog trailer.
- (3) Another combination over 22 m, but not over 36.5 m, long must display a long vehicle warning sign complying with this rule and rule 56.
- (4) Subrules (1), (2) and (3) do not apply to the extent of any inconsistency with a notice or permit issued under another law of this State that applies to the combination.
- (5) Road train warning signs must be used in pairs and fitted horizontally, one at the front and the other at the rear of the combination.
- (6) A long vehicle warning sign must be fitted horizontally at the rear of the combination.

**55. Warning signs not to be displayed on other vehicles**

- (1) A road train warning sign must not be displayed on a vehicle unless the vehicle is part of a combination or road train mentioned in rule 54(1) or (2).
- (2) A long vehicle warning sign must not be displayed on a vehicle unless the vehicle is a part of a combination or road train mentioned in rule 54(2) or (3).

**56. Specifications for warning signs**

- (1) A road train or long vehicle warning sign must be manufactured in one or 2 parts from sheet steel 0.8 mm thick or another material of at least the same stiffness, unless it is designed to be fixed to a vehicle using an adhesive.
- (2) The warning sign must be at least 1.02 m wide and at least 250 mm high.
- (3) A road train warning sign must display the words 'road train', and a long vehicle warning sign must display the words 'long vehicle', in black capital letters at least 180 mm high in typeface Series B (N) that complies with Australian Standard AS 1744 — 1975 *Forms of Letters and Numerals for Road Signs*.
- (4) If the warning sign is in 2 parts, one word of the expression 'road train' or 'long vehicle' must be on one part and the other word of the expression must be on the other part.
- (5) The warning sign must display the sign manufacturer's name or logo, and the brand and class of retro-reflective material used, in block letters not over 10 mm high.
- (6) The warning sign must have a black border.
- (7) The warning sign must be coated with yellow retro-reflective material of class 1 or 2 that meets Australian Standard AS 1906 — 1990 *Retro-reflective Materials and Devices for Road Traffic Control Purposes*.

r. 57

- (8) The warning sign must be fitted so —
- (a) no part of the sign is —
    - (i) over 1.8 m above ground level; or
    - (ii) under 500 mm above ground level;
- and
- (b) if the sign is in 2 parts — the parts are fitted at the same height above ground level.

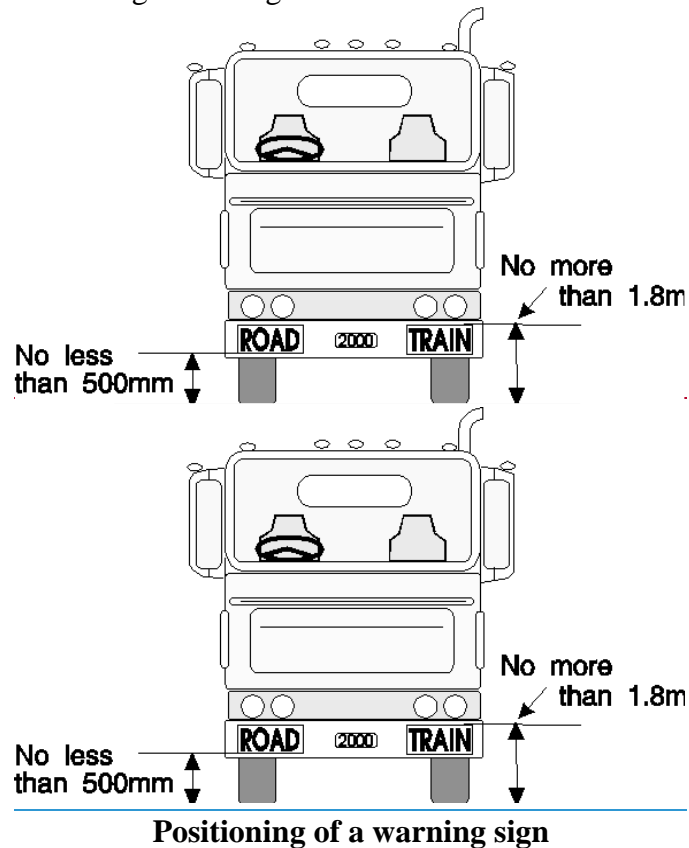

**57. Left-hand drive signs**

- (1) This rule applies to a motor vehicle with a GVM over 4.5 t that has the centre of a steering control to the left of the centre of the vehicle.



- (2) The vehicle must display the words 'left hand drive' on the rear of the vehicle.
- (3) The words must be in letters at least 75 mm high, and in a colour contrast with the background to the words.

## **Part 7 — Vehicle configuration and dimensions**

### **Division 1 — Axles**

#### **58. Axle configuration**

- (1) A motor vehicle, except an articulated bus, must have only —
  - (a) one axle group or single axle towards the front of the vehicle; and
  - (b) one axle group or single axle towards the rear of the vehicle.
- (2) An articulated bus must have —
  - (a) on its front section —
    - (i) only one axle group or single axle towards the front of the section; and
    - (ii) only one axle group or single axle towards the rear of the section;and
  - (b) on another section — only one axle group or single axle.
- (3) A trailer must have only —
  - (a) one axle group or single axle; or
  - (b) 2 axle groups, 2 single axles or one axle group and single axle, in the following configuration —
    - (i) one axle group or single axle towards the front of the vehicle, with all the wheels on the axle group or single axle connected to the steering mechanism for that part of the trailer;
    - (ii) one axle group or single axle towards the rear of the vehicle.
- (4) A semi-trailer that is extendible or is fitted with sliding axles must —
  - (a) have a securing device that —

- (i) can securely fix the extendible part or sliding axles to the rest of the vehicle in any position of adjustment provided;
- (ii) is located in a position that can prevent accidental or inadvertent release, if the device is mounted on the chassis of the vehicle;
- (iii) is fitted with a visible or audible warning system to indicate to a person standing beside the vehicle that the device is not engaged;
- (iv) is fitted with a way of preventing loss of air from the air brake supply, if the device uses air from the brake system and fails in a way allowing air to escape; and
- (v) is held in the applied position by direct mechanical action without the intervention of an electric, hydraulic or pneumatic device;

and

- (b) be built so the adjustable parts of the vehicle remain connected if the securing device fails.

**59. Relation between axles in axle group**

- (1) The axles in an axle group, except a twinsteer axle group, fitted to a vehicle with a GVM over 4.5 t must relate to each other through a load-sharing suspension system.
- (2) In this rule —
  - “**load-sharing suspension system**” means an axle group suspension system that —
    - (a) is built to divide the load between the tyres on the group so that no tyre carries a mass over 10% more than the mass that it would carry if the load were divided equally; and
    - (b) has effective damping characteristics on all axles of the group.

## **Division 2 — Dimensions**

### **60. Width**

- (1) A vehicle must not be over 2.5 m wide.
- (2) For subrule (1), the width of a vehicle is measured without taking into account any anti-skid device mounted on wheels, central tyre inflation systems, lights, mirrors, reflectors, signalling devices and tyre pressure gauges.

### **61. Length of motor vehicles**

- (1) A motor vehicle, except an articulated or controlled access bus, must not be over 12.5 m long.
- (2) A controlled access bus must not be over 14.5 m long.
- (3) An articulated bus must not be over 18 m long.

### **62. Length of trailers**

- (1) On a semi-trailer or a dog trailer —
  - (a) the distance between the point of articulation at the front of the trailer and the rear overhang line must not be over 9.5 m; and
  - (b) the distance between the point of articulation at the front of the trailer and the rear of the trailer must not be over 12.3 m.
- (2) A projection forward of the point of articulation at the front of a semi-trailer must be contained within a radius of 1.9 m from the point of articulation.

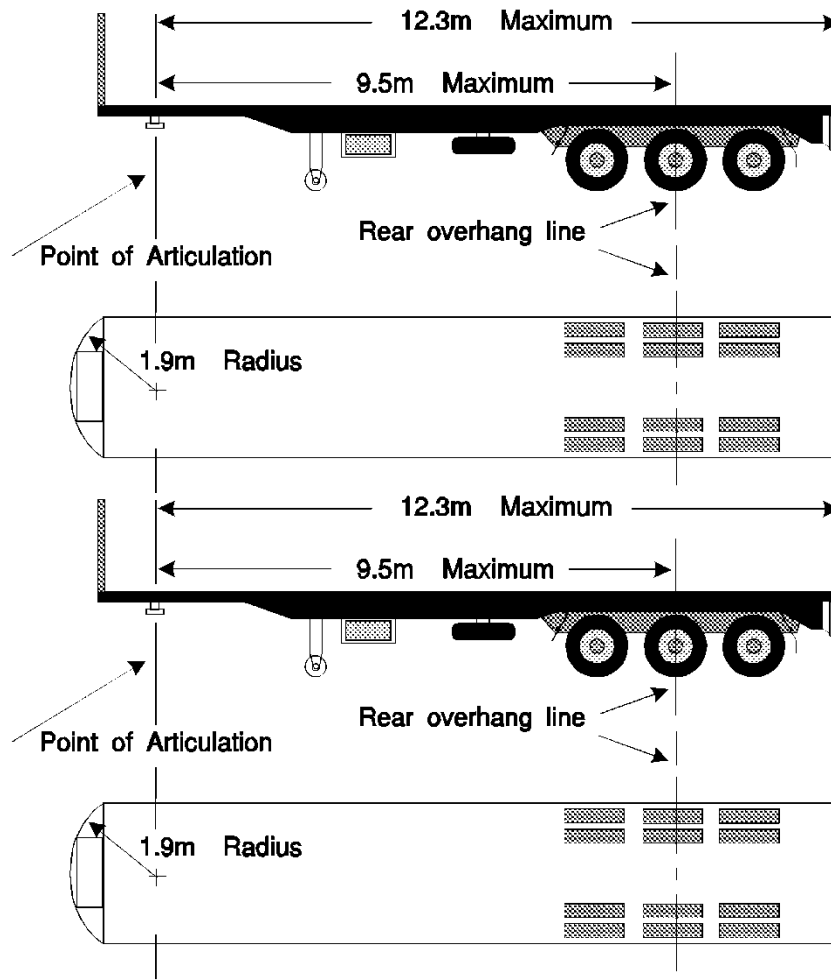

**Dimension limits for a semi-trailer**

- (3) If a semi-trailer has 2 or more points of articulation at the front of the trailer, it must comply with subrules (1) and (2) when measured at one of the points.
- (4) A trailer built to carry cattle, sheep, pigs or horses on 2 or more partly or completely overlapping decks must not have over 12.5 m of its length available for the carriage of animals.

- (5) For subrule (4), the length available for the carriage of animals on a trailer is measured from the inside of the front wall or door of the trailer to the inside of the rear wall or door of the trailer, with any intervening partitions disregarded.

**63. Length of combinations**

- (1) A combination must not be over —
- (a) for a B-double — 25 m long;
  - (b) for a road train — 53.5 m long;
  - (c) for a combination, except a road train, designed to carry vehicles on 2 or more partly or completely overlapping decks — 25 m long; and
  - (d) for another combination — 19 m long.
- (2) In a B-double built to carry cattle, sheep, pigs or horses, the 2 semi-trailers must not have over 18.8 m of their combined length available for the carriage of animals.
- (3) For subrule (2), the length available for the carriage of animals on a trailer is measured from the inside of the front wall or door of the trailer to the inside of the rear wall or door of the trailer, with any intervening partitions disregarded.

**64. Rear overhang**

- (1) The rear overhang of a semi-trailer, or dog trailer consisting of a semi-trailer and converter dolly, must not exceed the lesser of —
- (a) 60% of the distance between the point of articulation at the front and the rear overhang line; and
  - (b) 3.7 m.
- (2) A semi-trailer with 2 or more points of articulation at the front must comply with subrule (1) when measured at the same point used for measurement for compliance with rule 62(3).

- (3) The rear overhang of a trailer with only one axle group or single axle (except a semi-trailer) must not exceed the lesser of —
  - (a) the length of the load carrying area or body ahead of the rear overhang line; and
  - (b) 3.7 m.
- (4) The rear overhang of a vehicle not mentioned in subrule (1) or (3) must not exceed the lesser of —
  - (a) 60% of the distance between the centre of the front axle and the rear overhang line; and
  - (b) 3.7 m.

**65. Trailer drawbar length**

- (1) The distance between the coupling pivot point on the drawbar of a dog trailer, and the centre of the front axle group or of the front single axle of the trailer, must —
  - (a) not be over 5 m; and
  - (b) not be under 3 m, if the trailer is used in a road train over 19 m long.

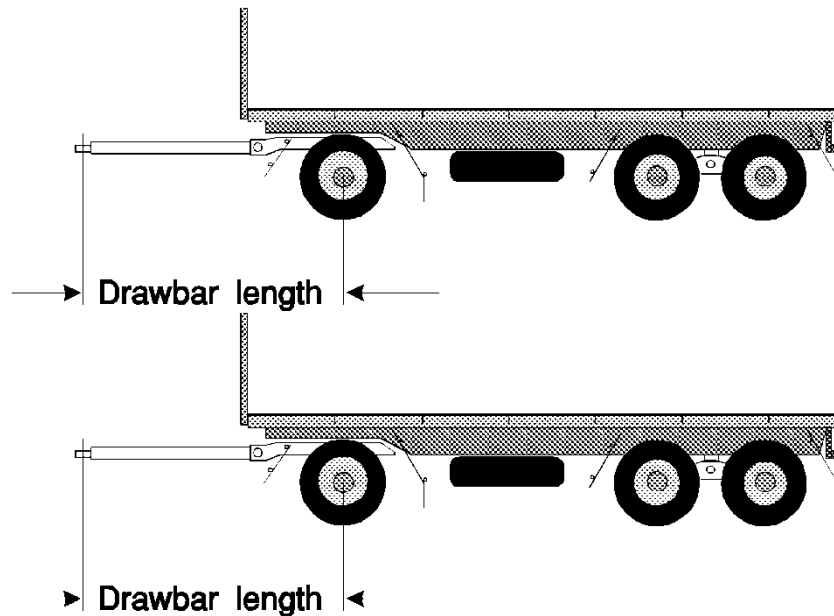

**Length of a drawbar on a dog trailer**

- (2) The distance between the coupling pivot point on a drawbar, and the centre of the axle group or single axle (except a semi-trailer) must not be over 8.5 m.

**66. Height**

- (1) A vehicle must not be over 4.3 m high.
- (2) However —
- (a) a vehicle built to carry cattle, sheep, pigs or horses must not be over 4.6 m high; and
  - (b) a double-deck bus must not be over 4.4 m high.

**67. Ground clearance**

- (1) In this rule —
- “ground clearance”** of a vehicle, means the minimum distance to the ground from a point on the underside of the vehicle,



except a point on a tyre, wheel, wheel hub, brake backing plate or flexible mudguard or mudflap of the vehicle.

- (2) A motor vehicle must have a ground clearance of —
- (a) at least 100 mm at any point within 1 m of an axle;
  - (b) at least one-thirtieth of the distance between the centres of adjacent axles at the midpoint between them; and
  - (c) at any other point — at least the distance that allows the vehicle to pass over a peak in the road with a gradient on either side of 1:15, if the wheels of one axle of the vehicle are on the slope on one side of the peak and the wheels of the next axle are on the slope on the other side.
- (3) However, subrule (2) does not apply to —
- (a) a motor vehicle with less than 4 wheels; or
  - (b) a combination that includes a motor vehicle with less than 4 wheels.

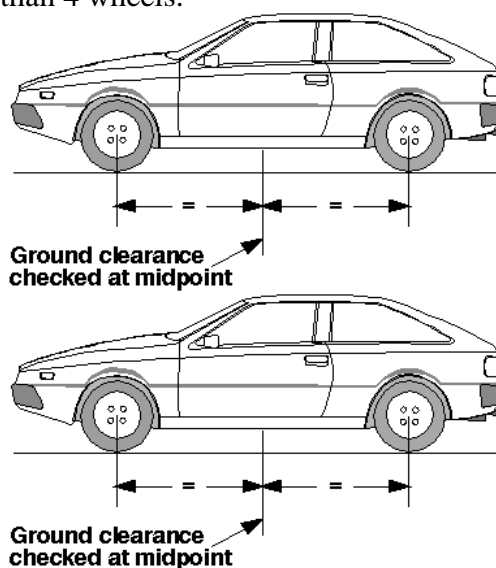

**Ground clearance at the midpoint between 2 axles**

**Road Traffic (Vehicle Standards) Rules 2002**

**Part 7** Vehicle configuration and dimensions

**Division 2** Dimensions

r. 67

---

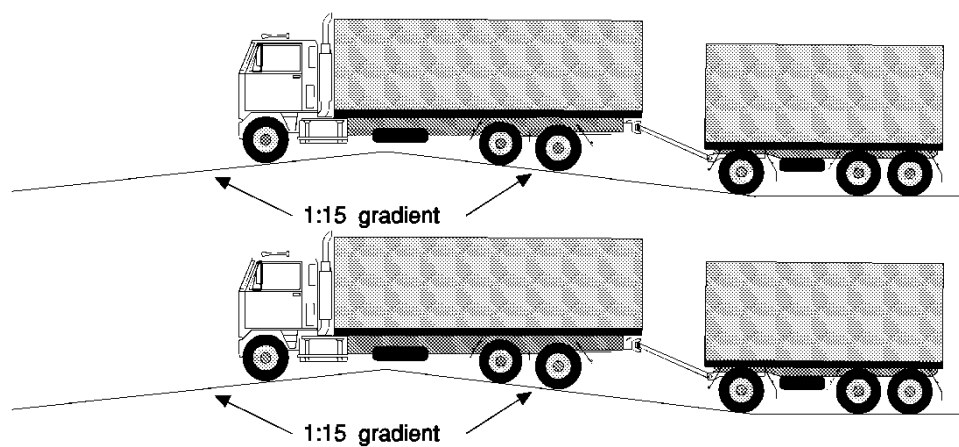

**Ground clearance over a peak in the road**

## **Part 8 — Lights and reflectors**

### **Division 1 — General requirements for lights**

#### **68. Certain requirements apply only at night-time**

The requirements of this Part for a light, except a brake or direction indicator light, to be visible over a stated distance apply only at night-time.

#### **69. Prevention of glare**

A light, except a high-beam headlight, fitted to a vehicle must be built and adjusted to provide the necessary amount of light, without dazzling the driver of another vehicle approaching, or being approached by, the vehicle.

#### **70. Pairs of lights**

- (1) If lights are required under the Vehicle Standards to be fitted to a vehicle in pairs —
  - (a) a light must be fitted on each side of the longitudinal axis of the vehicle;
  - (b) the centre of each light in a pair must be the same distance from the longitudinal axis of the vehicle;
  - (c) the centre of each light in a pair must be at the same height above ground level; and
  - (d) each light in a pair must project approximately the same amount of light of the same colour.
- (2) Subrule (1) applies to a motor bike with an attached sidecar as if the sidecar were not attached.

### **Division 2 — Headlights**

#### **71. Headlights to be fitted to vehicles**

- (1) A motor vehicle must be fitted with —
  - (a) one low-beam headlight if it is a moped, motor bike or motor trike with one front wheel; or

**Road Traffic (Vehicle Standards) Rules 2002**

**Part 8** Lights and reflectors

**Division 2** Headlights

**r. 72**

---

- (b) a pair of low-beam headlights if it has 4 or more wheels or is a motor trike, except a moped, with 2 front wheels.
- (2) If a motor vehicle built after 1934 can travel at over 60 km/h —
  - (a) each low-beam headlight mentioned in subrule (1) must be able to work in the high-beam position; or
  - (b) the vehicle must be fitted with —
    - (i) one headlight that can work in the high-beam position if the vehicle is required to have one low-beam headlight; or
    - (ii) a pair of headlights that can work in the high-beam position.
- (3) A motor bike may be equipped with a headlight modulation system that —
  - (a) varies the brightness of its high-beam headlight or low-beam headlight, but not both, at a rate of at least 200 and at most 280 flashes a minute; and
  - (b) is designed to operate only in the daytime.
- (4) Additional headlights may be fitted to a motor bike or motor trike, or a motor vehicle with 4 or more wheels that was built before 1970.
- (5) Additional pairs of headlights may be fitted to a motor vehicle with 4 or more wheels that was built after 1969.

**72. How headlights are to be fitted**

- (1) The centres of low-beam headlights fitted as a pair on a motor vehicle with 4 or more wheels must be at least 600 mm apart.
- (2) However, subrule (1) does not apply to a motor vehicle built before 1970 if the centres of its low-beam headlights —
  - (a) were under 600 mm apart when the vehicle was built; and
  - (b) are not nearer than they were when the vehicle was built.

- (3) Each low-beam headlight of a pair on a motor trike (except a moped) with 2 front wheels must not be over 400 mm from the nearer side of the vehicle.
- (4) The centre of a low-beam headlight fitted to a motor vehicle built after June 1953 must be —
  - (a) at least 500 mm above ground level; and
  - (b) not over 1.4 m above ground level.

**73. How single headlights are to be fitted**

- (1) A motor bike or motor trike with a single headlight fitted must have the light fitted in the centre.
- (2) Subrule (1) applies to a motor bike with an attached sidecar as if the sidecar were not attached.

**74. How additional headlights are to be fitted**

If 2 or more additional headlights are fitted to a motor vehicle with 4 or more wheels, the additional headlights must as far as possible be fitted in pairs.

**75. Performance of headlights**

- (1) When on, a headlight or additional headlight fitted to a vehicle must —
  - (a) show only white light; and
  - (b) project its main beam of light ahead of the vehicle.
- (2) Headlights must be fitted to a vehicle so their light does not reflect off the vehicle into the driver's eyes.

**76. Effective range of headlights**

- (1) This rule applies to a headlight that is on at night-time.
- (2) A low-beam headlight must illuminate the road ahead of the vehicle for at least 25 m.
- (3) A high-beam headlight must illuminate the road ahead of the vehicle for at least 50 m.

- (4) However, a low-beam headlight fitted to a motor vehicle built before 1931, or a moped, need only illuminate the road ahead of the vehicle for 12 m.

**77. Changing headlights from high-beam to low-beam position**

- (1) A motor vehicle built after 1934 that can travel at over 60 km/h must be fitted with —
- (a) a dipping device enabling the driver in the normal driving position —
    - (i) to change the headlights from the high-beam position to the low-beam position; or
    - (ii) simultaneously to switch off a high-beam headlight and switch on a low-beam headlight;
  - and
  - (b) for a vehicle built after June 1953 — a device to indicate to the driver that the headlights are in the high-beam position.
- (2) A headlight fitted to a vehicle not fitted with a dipping device mentioned in subrule (1)(a) must operate in the low-beam position.
- (3) When a headlight fitted to a vehicle is switched to the low-beam position, any other headlight on the vehicle must operate only in the low-beam position or be off.

**Division 3 — Parking lights**

**78. Parking lights**

- (1) A motor vehicle built after June 1953 must be fitted with —
- (a) a pair of parking lights if it is a motor trike with 2 front wheels (except a moped) or a motor vehicle with 4 or more wheels; or

- (b) at least one parking light if it is a motor bike with an attached sidecar, or a motor trike with one front wheel, (except a moped).
- (2) A pair of parking lights fitted to a motor vehicle with 4 or more wheels must be fitted with the centre of each light —
  - (a) at least 600 mm from the centre of the other light; and
  - (b) not over 510 mm from the nearer side of the vehicle.
- (3) However, a pair of parking lights fitted to a motor vehicle under 1300 mm wide may be fitted with the centre of each light not under 400 mm from the centre of the other light.
- (4) A parking light fitted to a motor trike with 2 front wheels must not be over 400 mm from the nearer side of the vehicle.
- (5) A parking light fitted to a motor bike with a sidecar must be fitted not over 150 mm from the side of the sidecar furthest from the motor bike.

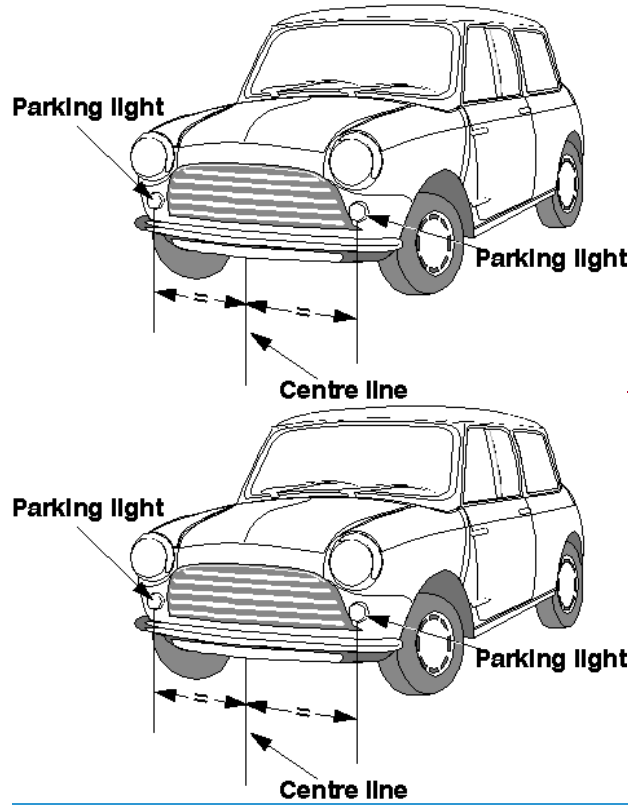

**Location of parking lights on a vehicle**

- (6) When on, a parking light must —
  - (a) show a white or yellow light visible 200 m from the front of the vehicle; and
  - (b) not use over 7 watts power.
- (7) A parking light fitted to a motor vehicle built after 1969 must be wired so the parking light is on when a headlight on the vehicle is on.
- (8) A parking light fitted to a sidecar attached to a motor bike must be wired to operate when a headlight, tail light or parking light on the motor bike is on.



- (9) For subrule (3), the width of a vehicle is measured disregarding any anti-skid device mounted on wheels, central tyre inflation systems, lights, mirrors, reflectors, signalling devices and tyre pressure gauges.

#### **Division 4 — Daytime running lights**

##### **79. Daytime running lights**

- (1) A pair of daytime running lights may be fitted to a motor vehicle.
- (2) A pair of daytime running lights fitted to a vehicle with 4 or more wheels must be fitted with the centre of each light —
- (a) at least 600 mm from the centre of the other light; and
  - (b) not over 510 mm from the nearer side of the vehicle.
- (3) However, a pair of daytime running lights fitted to a motor vehicle under 1300 mm wide may be fitted with the centre of each light not under 400 mm from the centre of the other light.

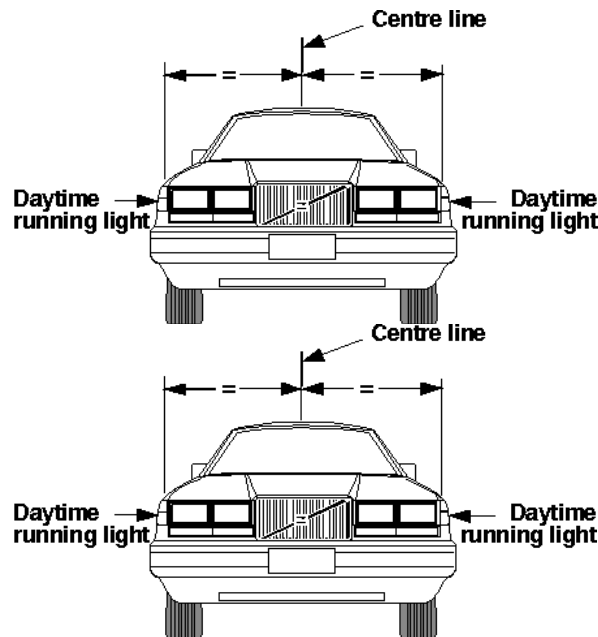

**Location of daytime running lights on a vehicle**

- (4) When on, a daytime running light must —
  - (a) show a white or yellow light visible from the front of the vehicle; and
  - (b) not use over 25 watts power.
- (5) Daytime running lights must be wired so they are off when a headlight, except a headlight being used as a flashing signal, is on.
- (6) For subrule (3), the width of a vehicle is measured disregarding any anti-skid device mounted on wheels, central tyre inflation systems, lights, mirrors, reflectors, signalling devices and tyre pressure gauges.

### **Division 5 — Tail lights**

#### **80. Tail lights generally**

- (1) A vehicle must have at least one tail light fitted on or towards the rear of the vehicle.
- (2) A motor trike with 2 rear wheels, or a motor vehicle with 4 or more wheels, built after 1959 must have at least one tail light fitted on or towards each side of the rear of the vehicle.
- (3) A trailer built after June 1973 must have at least one tail light fitted on or towards each side of the rear of the vehicle.
- (4) The centre of a tail light mentioned in subrule (1), (2) or (3) must not be over —
  - (a) 1.5 m above ground level; or
  - (b) if it is not practicable to fit the light lower — 2.1 m above ground level.
- (5) A vehicle may have one or more additional tail lights at any height above ground level.

#### **81. Pattern of fitting tail lights**

- (1) If only one tail light is fitted to a vehicle, it must be fitted in the centre or to the right of the centre of the vehicle's rear.
- (2) Subrule (1) applies to a motor bike with an attached sidecar as if the sidecar were not attached.
- (3) If 2 or more tail lights are fitted to a vehicle, at least 2 must be fitted as a pair.

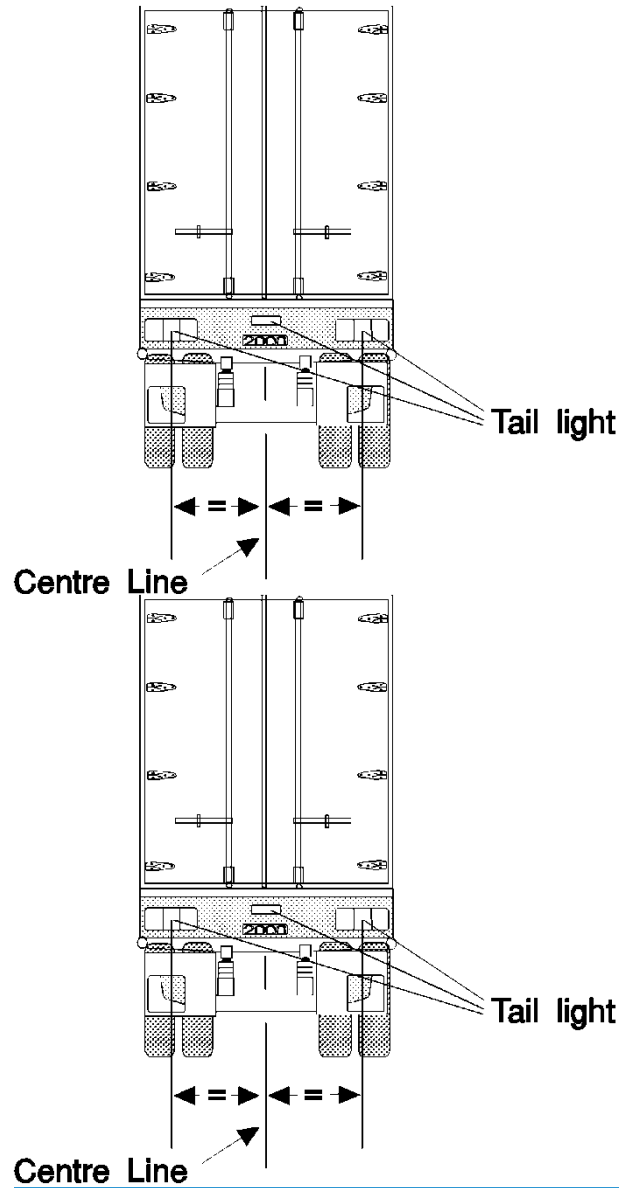

**Location of tail lights on a vehicle**

- (4) Tail lights fitted in accordance with this Division may also serve as rear clearance lights if they are fitted to a vehicle in accordance with rule 87(3).

**82. Performance of tail lights**

- (1) When on, a tail light of a vehicle must —
  - (a) show a red light visible 200 m from the rear of the vehicle; and
  - (b) not use over 7 watts power.
- (2) A tail light fitted to a street rod vehicle may incorporate a blue lens not over 20 mm in diameter.
- (3) A street rod vehicle is a vehicle that has been modified for safe road use and that —
  - (a) has a body and frame that were built before 1949; or
  - (b) is a replica of a vehicle the body and frame of which were built before 1949.

**83. Wiring of tail lights**

A tail light of a motor vehicle must be wired to come on, and stay on, when a parking light or headlight fitted to the vehicle is on, unless an external switch is fitted to operate the tail light.

**Division 6 — Number plate lights**

**84. Number plate lights**

- (1) At least one number plate light must be fitted to the rear of a vehicle.
- (2) When on, the number plate light or lights must illuminate a number plate on the rear of the vehicle with white light, so the characters on the number plate can be read at night-time 20 m from the rear of the vehicle.
- (3) A number plate light —
  - (a) may be combined with another light;
  - (b) must not project white light to the rear of the vehicle except by reflection;

- (c) must not obscure the characters on the number plate; and
- (d) must be wired to come on, and stay on, when a parking light, headlight or tail light fitted to the vehicle is on.

### **Division 7 — Clearance lights**

#### **85. Front clearance lights**

- (1) Front clearance lights may only be fitted to a vehicle that is at least 1.8 m wide.
- (2) A pair of front clearance lights must be fitted to a motor vehicle that is at least 2.2 m wide or is a prime mover.
- (3) The centre of a front clearance light must be —
  - (a) not over 400 mm from the nearer side of the vehicle; and
  - (b) if the vehicle was built after June 1953 —
    - (i) at least 750 mm higher than the centre of any low-beam headlight fitted to the vehicle; or
    - (ii) not lower than the top of the windscreen.
- (4) However, a front clearance light may be mounted on an external rear vision mirror or a mirror support if, when the mirror is correctly adjusted, no part of the lens of the clearance light is visible to a person in the normal driving position.
- (5) When on, a front clearance light must —
  - (a) show a yellow or white light visible 200 m from the front of the vehicle; and
  - (b) not use over 7 watts power.

#### **86. External cabin lights**

- (1) A motor vehicle fitted with front clearance lights may also have additional forward-facing lights on or above the roof of its cabin.

- (2) The additional forward-facing lights must be spaced evenly between the front clearance lights, with their centres at least 120 mm apart.
- (3) When on, an additional forward-facing light must —
  - (a) show a yellow or white light; and
  - (b) not use over 7 watts power.

**87. Rear clearance lights**

- (1) Rear clearance lights may only be fitted to a vehicle that is at least 1.8 m wide.
- (2) A pair of rear clearance lights must be fitted to the rear of a vehicle that is at least 2.2 m wide.
- (3) The centre of a rear clearance light must be —
  - (a) not over 400 mm from the nearer side of the vehicle; and
  - (b) if practicable, at least 600 mm above ground level.
- (4) When on, a rear clearance light must —
  - (a) show a red light visible 200 m from the rear of the vehicle; and
  - (b) not use over 7 watts power.

**Division 8 — Side marker lights**

**88. Vehicles needing side marker lights**

- (1) A pair of side marker lights must be fitted towards the rear of the sides of a motor vehicle that is over 7.5 m long and at least 2.2 m wide.
- (2) A pole-type trailer, and a motor vehicle built to tow a pole-type trailer, with at least one cross-bar or bolster must have a side marker light fitted to each side of the back or only cross-bar or bolster.

- (3) A pole-type trailer with 2 or more cross-bars or bolsters may also have a side marker light fitted to each side of the front cross-bar or bolster.
- (4) At least 2 side marker lights must be fitted to each side of —
  - (a) a trailer, except a pole-type trailer, that is at least 2.2 m wide and not over 7.5 m long; and
  - (b) a semi-trailer that is not over 7.5 m long.
- (5) At least 3 side marker lights must be fitted to each side of —
  - (a) a trailer, except a pole-type trailer, that is at least 2.2 m wide and over 7.5 m long; and
  - (b) a semi-trailer that is over 7.5 m long.
- (6) For subrules (1), (4) and (5), the width of a vehicle is measured disregarding any anti-skid device mounted on wheels, central tyre inflation systems, lights, mirrors, reflectors, signalling devices and tyre pressure gauges.

**89. Location of side marker lights**

- (1) The centre of a side marker light must not be over 150 mm from the nearer side of the vehicle.
- (2) A front side marker light fitted to a motor vehicle must be towards the front of the side of the vehicle with no part of the lens visible to the driver.
- (3) The centre of a front side marker light fitted to a trailer must be —
  - (a) within 300 mm of the front of the side of the trailer; or
  - (b) if the construction of the trailer makes it impracticable to comply with paragraph (a) — as near as practicable to the front of the trailer.
- (4) The centre of a rear side marker light fitted to a vehicle must be —
  - (a) within 300 mm of the rear of the side of the vehicle; or



- (b) if the construction of the vehicle makes it impracticable to comply with paragraph (a) — as near as practicable to the rear of the vehicle.
- (5) Side marker lights fitted to a vehicle must, as far as practicable, be evenly spaced along the side of the vehicle.
- (6) Subrules (2) to (5) do not apply to side marker lights fitted to a cross-bar or bolster of a pole-type trailer.
- (7) Only the side marker lights nearest to the rear need be fitted if complying with subrules (3) and (4) would result in the front and rear side marker lights being under 2.5 m apart.
- (8) A side marker light fitted to a vehicle must be fitted so —
  - (a) its centre is not over —
    - (i) 1.5 m above ground level; or
    - (ii) if it is not practicable to fit it lower — 2.1 m above ground level;
  - (b) its centre is at least 600 mm above ground level; and
  - (c) it is, as far as practicable, in a row of side marker lights along the side of the vehicle.
- (9) Subrule (8)(a) does not apply to a side marker light that is not required to be fitted to the vehicle by rule 88.

**90. Performance of side marker lights**

- (1) When on, a side marker light fitted to a vehicle must —
  - (a) show a light visible 200 m from the vehicle; and
  - (b) not use over 7 watts power.
- (2) When on, a side marker light fitted to a vehicle must show —
  - (a) to the front of the vehicle — a yellow light; and
  - (b) to the rear of the vehicle —
    - (i) if the light also operates as a rear light or reflector — a red light; and

- (ii) in any other case — a red or yellow light.
- (3) However, if a pole-type trailer with 2 or more cross-bars or bolsters has the side marker lights permitted by rule 88(3) —
  - (a) the side marker lights fitted to the front cross-bar or bolster may comply with subrule (2)(a) only; and
  - (b) the side marker lights fitted to the back cross-bar or bolster may comply with subrule (2)(b) only.

**91. Side marker lights and rear clearance lights**

The side marker light nearest to the rear of a vehicle may also be a rear clearance light for rule 87.

**Division 9 — Brake lights**

**92. Fitting brake lights**

- (1) A brake light must be fitted to the rear of a vehicle built after 1934.
- (2) A pair of brake lights must be fitted to the rear of —
  - (a) a motor vehicle built after 1959 that has 4 or more wheels;
  - (b) a motor trike built after 1959 that has 2 rear wheels; and
  - (c) a trailer built after June 1973.
- (3) The centre of a brake light must be —
  - (a) at least 350 mm above ground level; and
  - (b) not over —
    - (i) 1.5 m above ground level; or
    - (ii) if it is not practicable to fit the light lower — 2.1 m above ground level.
- (4) A vehicle may be fitted with one or more additional brake lights.

- (5) The centre of an additional brake light must be at least 350 mm above ground level.
- (6) If only one brake light is fitted to a vehicle, it must be fitted in the centre or to the right of the centre of the vehicle's rear.
- (7) Subrule (6) applies to a motor bike with an attached sidecar as if the sidecar were not attached.

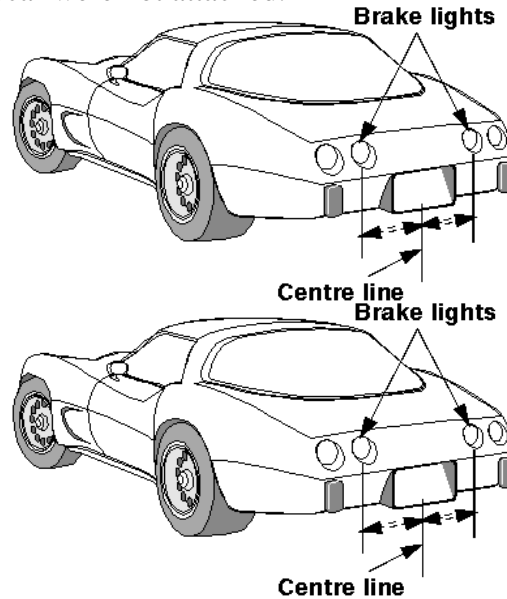

**Location of brake lights on a vehicle**

**93. Performance and operation of brake lights**

- (1) When on, a brake light must show a red light visible 30 m from the rear of the vehicle.
- (2) A brake light fitted to a street rod vehicle may incorporate a blue lens not over 20 mm in diameter.
- (3) A brake light fitted to a motor vehicle must come on, if it is not already on, when —
  - (a) for a vehicle with 4 or more wheels or built after 1974 — a service brake is applied; or
  - (b) for another vehicle — the rear wheel brake is applied.

- (4) Subrule (3) does not apply if the controls in the vehicle that start the engine are in a position that makes it impossible for the engine to operate.
- (5) A brake light on a trailer must come on when —
  - (a) the brake light of the towing vehicle comes on; or
  - (b) a brake control on the towing vehicle, which independently activates the service brake on the trailer, is operated.
- (6) A brake light may be operated by an engine brake, retarder or similar device if the device does not interfere with the proper operation of the brake light.
- (7) A street rod vehicle is a vehicle that has been modified for safe road use and that —
  - (a) has a body and frame that were built before 1949; or
  - (b) is a replica of a vehicle the body and frame of which were built before 1949.

### **Division 10 — Reversing lights**

#### **94. Reversing lights**

- (1) One or more reversing lights may be fitted to the rear of a vehicle and on each side towards the rear of the vehicle.
- (2) A reversing light must have its centre not over 1.2 m above ground level.
- (3) When on, a reversing light must show a white or yellow light to the rear or to the side and rear of the vehicle.
- (4) A reversing light fitted to a motor vehicle must be wired so it operates only when the vehicle is reversing or in reverse gear.
- (5) A reversing light fitted to a trailer must be wired so it operates only when a motor vehicle towing the trailer is reversing or in reverse gear.
- (6) A yellow reversing light may also operate as a direction indicator light.

### **Division 11 — Direction indicator lights**

#### **95. Direction indicator lights on motor vehicles**

- (1) A motor vehicle with 4 or more wheels that was built after August 1966 must have —
  - (a) a pair of direction indicator lights fitted on or towards its front that face forwards; and
  - (b) a pair of direction indicator lights fitted on or towards its rear that face backwards.
- (2) A motor vehicle with less than 4 wheels that was built after June 1975 must have —
  - (a) a pair of direction indicator lights fitted on or towards its front that face forwards; and
  - (b) a pair of direction indicator lights fitted on or towards its rear that face backwards.
- (3) A motor vehicle that is not required to have direction indicator lights may have —
  - (a) one or more pairs of direction indicator lights that are visible from both the front and rear of the vehicle; or
  - (b) both —
    - (i) a pair of direction indicator lights fitted on or towards its front that face forwards; and
    - (ii) a pair of direction indicator lights fitted on or towards its rear that face backwards.

#### **96. Direction indicator lights on trailers**

- (1) A trailer built after June 1973 must have a pair of direction indicator lights fitted on or towards its rear that face backwards.
- (2) A trailer that is not required to have direction indicator lights may have one or more pairs of direction indicator lights fitted on or towards its rear that face backwards.

#### **97. Location of direction indicator lights**

- (1) A pair of direction indicator lights fitted to a vehicle must have the centre of each light at least —
  - (a) for a motor bike or the single wheel end of a motor trike — 300 mm from the centre of the other light;
  - (b) for lights fitted at the 2 wheel end of a motor trike — 600 mm from the centre of the other light, unless the centre of each direction indicator light is not over 400 mm from the nearer side of the vehicle;
  - (c) for another vehicle with a width of not over 1300 mm — 400 mm from the centre of the other light; and
  - (d) for another vehicle with a width of over 1300 mm — 600 mm from the centre of the other light.
- (2) The centre of each direction indicator light must be at least 350 mm above ground level.
- (3) The centre of each light in a pair of direction indicator lights required to be fitted to a vehicle must not be over —
  - (a) 1.5 m above ground level; or
  - (b) if it is not practicable for the light to be fitted lower — 2.1 m above ground level.
- (4) For subrule (1), the width of a vehicle is measured disregarding any anti-skid device mounted on wheels, central tyre inflation systems, lights, mirrors, reflectors, signalling devices and tyre pressure gauges.

**98. Operation and visibility of direction indicator lights**

- (1) A direction indicator light fitted to a motor vehicle must —
  - (a) when operating, display regular flashes of light at a rate of not over 120 flashes a minute and —
    - (i) for a motor vehicle with 4 or more wheels — at least 60 flashes a minute; and
    - (ii) for another motor vehicle — at least 45 flashes a minute;

- (b) be able to be operated by a person in the normal driving position;
  - (c) be wired to an audible or visible device in the vehicle that tells the driver that the direction indicator light is operating; and
  - (d) flash at the same time and rate as any other direction indicator lights fitted on the same side of the vehicle.
- (2) A direction indicator light fitted to a side of a trailer must, when operating, flash at the same time and rate as the direction indicator light or lights fitted to the same side of the motor vehicle towing the trailer.
- (3) The flashes of light displayed by a direction indicator light must be —
- (a) if the light faces forwards — white or yellow;
  - (b) if the light faces backwards —
    - (i) yellow; or
    - (ii) for a vehicle built before July 1973 — yellow or red;
- and
- (c) if the light faces out from the side of the vehicle —
    - (i) white or yellow towards the front and side;
    - (ii) for a vehicle built before July 1973 — yellow or red towards the rear and side; and
    - (iii) for a vehicle built after June 1973 — yellow towards the rear and side.
- (4) If a motor vehicle's direction indicator lights display only yellow light, the vehicle may be equipped to allow the lights to operate simultaneously on both sides of the vehicle, if a visible or audible signal tells the driver when the lights are operating simultaneously.

- (5) When on, a direction indicator light must be visible 30 m from —
  - (a) if the light faces forwards — the front of the vehicle;
  - (b) if the light faces backwards — the rear of the vehicle; or
  - (c) if the light faces out from the side of the vehicle — that side of the vehicle.
- (6) When on, each direction indicator light in at least one pair of lights fitted on or towards the front of a prime mover, or a motor vehicle over 7.5 m long, must be visible at a point —
  - (a) 1.5 m at right angles from the side of the vehicle where the light is fitted; and
  - (b) in line with the rear of the vehicle.

### **Division 12 — Fog lights**

#### **99. Front fog lights**

- (1) A pair of front fog lights may be fitted to a motor vehicle with 4 or more wheels.
- (2) A pair of front fog lights or a single front fog light may be fitted to a motor bike or motor trike.
- (3) A pair of front fog lights fitted to a motor vehicle with 4 or more wheels must have the centre of each light not over 400 mm from the nearer side of the vehicle unless the centres of the lights are at least 600 mm apart.
- (4) If the top of the front fog light is higher than the top of any low-beam headlight on the vehicle, the centre of the fog light must not be higher than the centre of the low-beam headlight.
- (5) A front fog light must —
  - (a) when on —
    - (i) project white or yellow light in front of the vehicle; and



- (ii) be a low-beam light;
- (b) be able to be operated independently of any headlight;  
and
- (c) be fitted so the light from it does not reflect off the  
vehicle into the driver's eyes.

**100. Rear fog lights**

- (1) A vehicle may have fitted to its rear —
  - (a) a pair of rear fog lights; or
  - (b) one rear fog light fitted on or to the right of the centre of the vehicle.
- (2) Subrule (1)(b) applies to a motor bike with an attached sidecar as if the sidecar were not attached.
- (3) A rear fog light must —
  - (a) have its centre —
    - (i) not over 1.5 m above ground level; and
    - (ii) at least 100 mm from the centre of a brake light;
  - (b) when on, project red light behind the vehicle;
  - (c) not use over 27 watts power; and
  - (d) be wired to a visible device in the vehicle that tells the driver that the rear fog light is operating.

**Division 13 — Interior lights**

**101. Interior lights**

A vehicle may be fitted with interior lights that illuminate any interior part of the vehicle.

**Division 14 — Reflectors generally**

**102. General requirements for reflectors**

- (1) A reflector fitted to a vehicle must show a red, yellow or white reflection of light when light is projected directly onto the reflector at night-time by a low-beam headlight that —
  - (a) is 45 m from the reflector; and
  - (b) complies with the Vehicle Standards.

- (2) The reflection must be clearly visible from the position of the headlight.

### **Division 15 — Rear reflectors**

#### **103. Rear reflectors**

- (1) A motor vehicle with 4 or more wheels and a trailer must have a rear-facing red reflector towards each side of its rear.
- (2) A motor bike, a sidecar attached to a motor bike, and a motor trike, must have a rear-facing red reflector.
- (3) The centre of each reflector must be —
- (a) at the same height above ground level; and
  - (b) not over 1.5 m above ground level.
- (4) However, subrule (3) does not apply to a reflector fitted to a sidecar attached to a motor bike.
- (5) A reflector fitted to a motor vehicle with 4 or more wheels or to a trailer must not be over 400 mm from the nearer side of the vehicle.
- (6) A vehicle fitted with rear-facing red reflectors in accordance with subrule (1) or (2) may be fitted with additional red reflectors at any height above ground level or at any distance from the side of the vehicle.

### **Division 16 — Side reflectors**

#### **104. Compulsory side reflectors on pole-type trailers**

- (1) Yellow or red side-facing reflectors must be fitted to the pole of a pole-type trailer so —
- (a) one reflector is fitted to the middle third of the left and right faces of the pole;
  - (b) the front reflector is not over 3 m from the front of the trailer; and

- (c) the other reflectors are not over 3 m apart.
- (2) Additional side-facing reflectors may be fitted to a pole-type trailer in accordance with rule 105.

**105. Optional side reflectors**

- (1) A vehicle may be fitted with side-facing reflectors.
- (2) A side-facing reflector —
  - (a) towards the front of the vehicle must be yellow or white;
  - (b) towards the rear of the vehicle must be yellow or red; and
  - (c) on the central part of the vehicle must be yellow.

**Division 17 — Front reflectors**

**106. Compulsory front reflectors on trailers**

- (1) A front-facing white or yellow reflector must be fitted towards each side of the front of —
  - (a) a semi-trailer, except a pole-type trailer;
  - (b) the front cross-bar or bolster of a pole-type trailer; and
  - (c) a trailer that is at least 2.2 m wide.
- (2) Each reflector must have its centre —
  - (a) at the same height above ground level;
  - (b) not over 1.5 m above ground level; and
  - (c) not over 400 mm from the nearer side of the vehicle.
- (3) Additional front-facing reflectors may be fitted to a trailer mentioned in subrule (1) in accordance with rule 107.

**107. Optional front reflectors**

- (1) A motor vehicle with 4 or more wheels or a trailer may have one or more front-facing white or yellow reflectors fitted towards each side of its front.
- (2) A motor vehicle with less than 4 wheels may have one or more front-facing white or yellow reflectors.
- (3) The centre of at least one reflector on each side of the front of the vehicle must be —
  - (a) at the same height above ground level as the centre of the other reflector;
  - (b) the same distance from the longitudinal axis of the vehicle as the centre of the other reflector; and
  - (c) at least —
    - (i) for a vehicle with a width under 1300 mm — 400 mm from the centre of the other reflector; and
    - (ii) for another vehicle — 600 mm from the centre of the other reflector.
- (4) For subrule (3)(c), the width of a vehicle is measured disregarding any anti-skid device mounted on wheels, central tyre inflation systems, lights, mirrors, reflectors, signalling devices and tyre pressure gauges.

**Division 18 — Warning lights and signs on buses carrying children**

**108. Application of Division**

This Division applies to a bus that is used mainly for carrying children if the bus is fitted with warning lights after June 1999.

**109. Fitting of warning lights and signs**

- (1) Two warning lights and a warning sign must be fitted to the front and rear of the bus.
- (2) The warning lights must be fitted —
  - (a) on each side of, and the same distance from, the centre of the warning sign;
  - (b) with the edge of the warning sign not over 100 mm from the nearest point on the lens of the warning lights;
  - (c) with the distance between the warning lights at least 300 mm at the nearest point; and
  - (d) so no part of the bus obstructs the light displayed —
    - (i) 30° to the left and right of the centre of each light; and
    - (ii) 10° above and below the centre of each light.
- (3) The warning lights may be on the warning sign if the words or image on the sign are not obscured.
- (4) The warning lights at the same end of the bus must be fitted —
  - (a) at the same height;
  - (b) as high as practicable; and
  - (c) with the lowest point on the lens of each light not lower than midway between the highest and lowest points on the bus body.
- (5) If the centres of the warning lights are under 1.8 m above ground level, no part of the warning lights or warning sign may be on the left of the bus.
- (6) This rule applies to a bus despite any requirement of a third edition ADR.

**110. Operation and performance of warning lights**

- (1) When operating, a warning light must display regular flashes of yellow light at a rate of at least 90, and not over 180, flashes a minute.
- (2) The warning lights at the same end of the bus must flash alternately.
- (3) Unless the driver has turned the warning lights off, they must operate automatically when a door on the bus opens and for at least 10, and not over 20, seconds after all the doors on the bus have closed.
- (4) The bus must have a visible or audible signal that tells the driver when the warning lights are operating.
- (5) The bus must be fitted with a switch that allows the driver to turn the warning lights off.
- (6) A warning light must have —
  - (a) an effective lit lens area of at least 60 cm<sup>2</sup>; and
  - (b) a luminous intensity (in candela) of at least the values mentioned in Table 1 when measured at the angles mentioned in the Table.

**Table 1**

Vertical angle from centre of light	Horizontal angle from centre of light								
	-30°	-20°	-10°	-5°	0°	5°	10°	20°	30°
10°				50	80	50			
5°		180	320	350	450	350	320	180	
0°	75	450	1000	1250	1500	1250	1000	450	75
-5°	40	270	450	570	600	570	450	270	40
-10°				75	75	75			

- (7) For subrule (6)(b), the luminous intensity of a light is to be measured in accordance with the test method mentioned in third edition ADR 6.

**111. Specifications for warning signs**

- (1) A warning sign at the front of the bus must —
  - (a) display the words ‘school bus’ in capital letters at least 100 mm high; or
  - (b) display an image of 2 children in the same proportions as the children in Australian Standard AS 1743 — 2001 *Road Signs — Specifications (Image W6-3)*, with the image of the taller child at least 230 mm high.
- (2) A warning sign at the rear of the bus must display an image of 2 children in the same proportions as the children in Australian Standard AS 1743 — 2001 *Road Signs — Specifications (Image W6-3)*, with the image of the taller child at least 230 mm high.
- (3) The warning sign mentioned in subrules (1)(b) and (2) must —
  - (a) be a rectangular shape at least —
    - (i) if warning lights are on the warning sign — 550 mm wide and 400 mm high; and
    - (ii) in any other case — 400 mm wide and 250 mm high;
  - (b) have a black border; and
  - (c) have black graphics and be coated with yellow retro-reflective material of class 1 or 2 that meets Australian Standard AS 1906 — 1990 *Retro-reflective Materials and Devices for Road Traffic Control Purposes*.

**Division 19 — Other lights, reflectors, rear marking plates or signals**

**112. Other lights and reflectors**

- (1) In this rule —

“**exempt vehicle**” means —

  - (a) an emergency vehicle;



- (b) an Australian Protective Service vehicle;
- (c) an Australian Customs Service vehicle;
- (d) an Airservices Australia vehicle; or
- (e) any other type of vehicle approved by the Director General and used in conformity with any conditions that may be imposed by the Director General;

**“special use vehicle”** means —

- (a) a vehicle built or fitted for use in hazardous situations on a road;
  - (b) a vehicle that because of its dimensions is permitted to be driven on a road only in accordance with a notice or permit issued under a law of this State;
  - (c) a vehicle built or fitted to accompany a vehicle mentioned in paragraph (b);
  - (d) a bus fitted, before July 1999, with a sign telling road users that the bus carries children;
  - (e) a transport enforcement vehicle;
  - (f) any other type of vehicle approved by the Director General and used in conformity with any conditions that may be imposed by the Director General.
- (2) A vehicle may be fitted with any light or reflector not mentioned in the Vehicle Standards.
- (3) However, unless subrule (4) applies, a vehicle must not display —
- (a) a light that flashes; or
  - (b) a light or reflector that —
    - (i) shows a red light to the front;
    - (ii) shows a white light to the rear; or
    - (iii) is shaped or located in a way that reduces the effectiveness of a light or reflector that is

required to be fitted to the vehicle under the Vehicle Standards.

- (4) Despite any requirement of a third edition ADR —
- (a) an exempt vehicle may be fitted with any light or reflector approved by the Director General; and
  - (b) a special use vehicle may be fitted with one or more flashing yellow lights (or flashing lights of another colour or colours approved by the Director General).

*[Rule 112 amended in Gazette 3 Jan 2003 p. 4.]*

### **113. Rear marking plates**

- (1) In this rule —
- “rear marking plate”** means a rear marking plate complying with rule 13.6.101 of third edition ADR 13/00 as published in the *Periodic Gazette* issue of the *Commonwealth of Australia Gazette* No. GN 48 of 13 December 1989.
- (2) Rear marking plates must be fitted to —
- (a) a motor vehicle with a GVM over 12 t, except a bus fitted with hand grips or similar equipment for standing passengers to hold; and
  - (b) a trailer with a GTM over 10 t.
- (3) Subrule (2) applies to a vehicle even if it was built before the date stated in the ADR.
- (4) Rear marking plates may be fitted to a motor vehicle with a GVM not over 12 t or a trailer with a GTM not over 10 t.

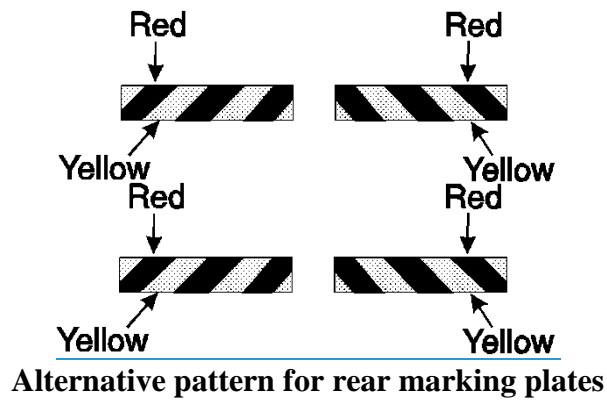
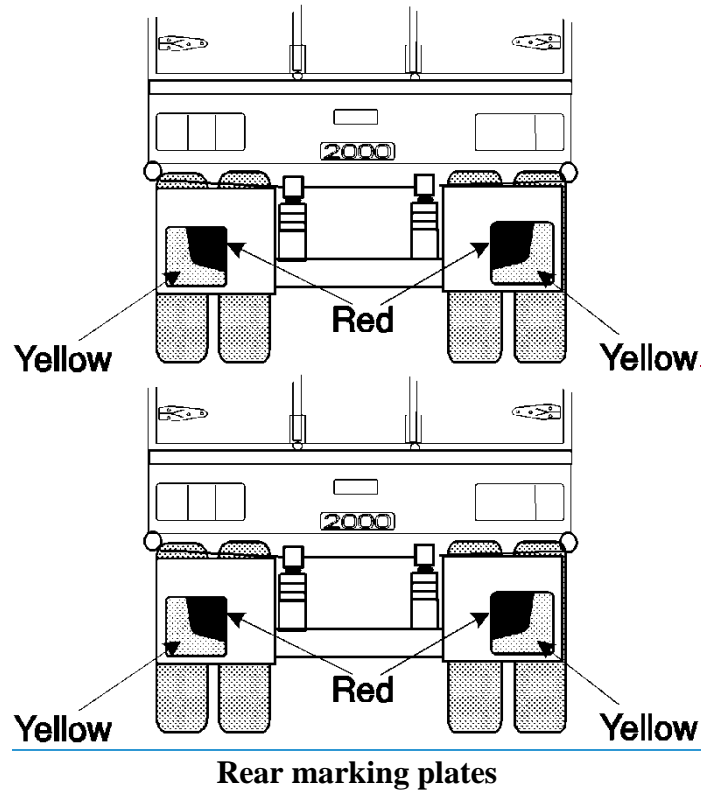

**114. Signalling devices**

- (1) This rule applies to a motor vehicle if —

- (a) the vehicle is not fitted with a brake light or direction indicator light mentioned in Division 9 or 11; and
  - (b) the construction of the vehicle would otherwise prevent the driver from hand signalling an intention —
    - (i) to turn or move the vehicle to the right; or
    - (ii) to stop or suddenly reduce the speed of the vehicle.
- (2) The vehicle must be fitted with a mechanical signalling device or a pair of turn signals.

**115. Mechanical signalling devices**

- (1) A mechanical signalling device must —
- (a) be fitted to the right side of the vehicle;
  - (b) be able to be operated by the driver from a normal driving position;
  - (c) consist of a white or yellow representation of an open human hand at least 150 mm long; and
  - (d) be constructed so that the driver of the vehicle can keep the device —
    - (i) in a neutral position so it is unlikely that the driver of another vehicle or anyone else would regard it as a signal;
    - (ii) in a horizontal position with the palm of the hand facing forwards and the fingers pointing out at a right angle to the vehicle to signal an intention to turn or move right; and
    - (iii) with the palm of the hand facing forwards and the fingers pointing upwards to signal an intention to stop or reduce speed suddenly.
- (2) When the mechanical signalling device is in a position mentioned in subrule (1)(d)(ii) or (iii), the complete hand must

be clearly visible from both the front and the rear of the vehicle, at a distance of 30 m.

*[Rule 115 amended in Gazette 3 Jan 2003 p. 4.]*

**116. Turn signals**

A turn signal must —

- (a) consist of a steady or flashing illuminated yellow sign at least 150 mm long and 25 mm wide that —
  - (i) when in operation — is kept horizontal; and
  - (ii) when not in operation — is kept in a position so it is unlikely that the driver of another vehicle or anyone else would regard it as a signal;
- (b) be fitted to the side of the motor vehicle at least 500 mm and not over 2.1 m above ground level, in a position so the driver of the vehicle, from the normal driving position, can see whether the signal is in operation;
- (c) be able to be operated by the driver from the normal driving position; and
- (d) when in operation, be visible from both the front and rear of the vehicle at a distance of 30 m.

*[Rule 116 amended in Gazette 3 Jan 2003 p. 4.]*

**Division 20 — Vehicles not required to have lights or reflectors**

**117. Certain vehicles used in daytime**

This Part does not apply to a vehicle built before 1931 that is used only in the daytime.

**118. Certain vehicles used for collection or exhibition purposes**

This Part does not apply to a vehicle built before 1946 that is used mainly for exhibition purposes.

## **Part 9 — Braking systems**

### **Division 1 — Brake requirements for all vehicles**

#### **119. Parts of a braking system**

- (1) A brake tube or hose fitted to a vehicle must —
  - (a) be manufactured from a material appropriate to its intended use in the vehicle;
  - (b) be long enough to allow for the full range of steering and suspension movements of the vehicle; and
  - (c) be fitted to prevent it being damaged during the operation of the vehicle by —
    - (i) a source of heat; or
    - (ii) any movement of the parts to which it is attached or near.
- (2) Each component of the braking system of a vehicle with a GVM over 4.5 t must comply with the design and performance requirements of —
  - (a) a relevant Australian Standard or British Standard as in force when this subrule commenced; or
  - (b) a relevant standard approved by any of the following bodies and as in force when this subrule commenced —
    - (i) American Society of Automotive Engineers;
    - (ii) American National Standards Institute;
    - (iii) Japanese Standards Association;
    - (iv) Deutsches Institut für Normung;
    - (v) International Organisation for Standardisation.

#### **120. Provision for wear**

The braking system of a vehicle must allow for adjustment to take account of normal wear.

**121. Supply of air or vacuum to brakes**

- (1) If air brakes are fitted to a vehicle —
  - (a) the compressor supplying air to the brakes must be able to build up air pressure to at least 80% of the governor cut-out pressure in not over 5 minutes after the compressed air reserve is fully used up;
  - (b) for a vehicle with a GVM over 4.5 t — the air storage tanks must have sufficient capacity to allow 5 applications of the service brakes before the air pressure drops below half the governor cut-out pressure;
  - (c) there must be an automatic or manual condensate drain valve at the lowest point of each air brake reservoir in the system; and
  - (d) any spring brake fitted to the vehicle must not operate before the warning mentioned in rule 125(4)(a) or 128(3)(a) has been given.
- (2) If vacuum brakes are fitted to a vehicle, the vacuum supply must be able to build up a vacuum —
  - (a) to the level when the warning signal mentioned in rule 125(4)(a) or 128(3)(a) no longer operates within 30 seconds after the vacuum reserve is fully used up; and
  - (b) to the normal working level within 60 seconds after the vacuum reserve is fully used up.
- (3) In this rule —

**“spring brake”** means a brake using one or more springs to store the energy needed to operate the brake.

**122. Performance of braking systems**

- (1) One sustained application of the brake of a motor vehicle built after 1930, or a combination that includes a motor vehicle built after 1930, must be able to produce the performance mentioned in subrules (2) to (7) —
  - (a) when the vehicle or combination is on a dry, smooth, level road surface, free from loose material;

**Road Traffic (Vehicle Standards) Rules 2002**

**Part 9** Braking systems

**Division 1** Brake requirements for all vehicles

**r. 122**

---

- (b) whether or not the vehicle or combination is loaded; and
  - (c) without part of the vehicle or combination moving outside a straight path —
    - (i) centred on the longitudinal axis of the vehicle or combination before the brake was applied; and
    - (ii) 3.7 m wide.
- (2) The braking system of a motor vehicle with a gross mass under 2.5 t must bring the vehicle from a speed of 35 km/h to a stop within —
- (a) 12.5 m when the service brake is applied; and
  - (b) 30 m when the emergency brake is applied.
- (3) The braking system of a motor vehicle with a gross mass of at least 2.5 t must bring the vehicle from a speed of 35 km/h to a stop within —
- (a) 16.5 m when the service brake is applied; and
  - (b) 40.5 m when the emergency brake is applied.
- (4) The braking system of a motor vehicle with a gross mass under 2.5 t must decelerate the vehicle from any speed at which the vehicle can travel, by an average of at least —
- (a) 3.8 m a second a second when the service brake is applied; and
  - (b) 1.6 m a second a second when the emergency brake is applied.
- (5) The braking system of a motor vehicle with a gross mass of at least 2.5 t must decelerate the vehicle from any speed at which the vehicle can travel, by an average of at least —
- (a) 2.8 m a second a second when the service brake is applied; and
  - (b) 1.1 m a second a second when the emergency brake is applied.



- (6) The braking system of a motor vehicle with a gross mass under 2.5 t must achieve a peak deceleration of the vehicle from any speed at which the vehicle can travel, of at least —
- (a) 5.8 m a second a second when the service brake is applied; and
  - (b) 1.9 m a second a second when the emergency brake is applied.
- (7) The braking system of a motor vehicle with a gross mass of at least 2.5 t must achieve a peak deceleration of the vehicle from any speed at which the vehicle can travel, of at least —
- (a) 4.4 m a second a second when the service brake is applied; and
  - (b) 1.5 m a second a second when the emergency brake is applied.
- (8) The parking brake of a vehicle must be able to hold the vehicle stationary on a 12% gradient.

### **Division 2 — Motor vehicle braking systems**

#### **123. What braking system a motor vehicle must have**

- (1) In this rule —
- “independent brake”**, for a vehicle, means a brake that is operated entirely separately from any other brake on the vehicle, except for any drum, disc or part, on which a shoe, band or friction pad makes contact, that is common to 2 or more brakes.
- (2) A motor vehicle with 4 or more wheels built or used mainly for transporting goods or people by road must be fitted with —
- (a) a braking system that —
    - (i) consists of brakes fitted to all wheels of the vehicle; and

- (ii) has at least 2 separate methods of activation, arranged so effective braking remains on at least 2 wheels if a method fails;
  - or
  - (b) 2 independent brakes, each of which, when in operation, acts directly on at least half the number of wheels of the vehicle.
- (3) The braking system of a motor vehicle mentioned in subrule (2) that was built after 1945 must have a service brake operating on all wheels that, when applied —
- (a) acts directly on the wheels and not through the vehicle's transmission; or
  - (b) acts on a shaft between a differential of the vehicle and a wheel.
- (4) The braking system of a motor vehicle with 4 or more wheels must have a parking brake that —
- (a) is held in the applied position by direct mechanical action without the intervention of an electrical, hydraulic or pneumatic device;
  - (b) is fitted with a locking device that can hold the brake in the applied position; and
  - (c) has its own separate control.
- (5) The parking brake may also be the emergency brake.
- (6) If 2 or more independent brakes are fitted to a motor vehicle with 4 or more wheels, the brakes must be arranged so brakes are applied to all the wheels on at least one axle of the vehicle when any brake is operated.
- (7) A motor bike or motor trike must be fitted with —
- (a) 2 independent brakes; or
  - (b) a single brake that acts directly on all wheels of the vehicle and is arranged so effective braking remains on at least one wheel if a part of the system fails.

- (8) Subrule (7) applies to a motor bike with a sidecar attached as if the sidecar were not attached.
- (9) A motor trike must have a parking brake that is held in the applied position by mechanical means.

**124. Operation of brakes on motor vehicles**

The braking system on a motor vehicle must be arranged to allow the driver of the motor vehicle to apply the brakes from a normal driving position.

**125. Air or vacuum brakes on motor vehicles**

- (1) If a motor vehicle has air brakes, the braking system of the vehicle must include at least one air storage tank.
- (2) If a motor vehicle has vacuum brakes, the braking system of the vehicle must include at least one vacuum storage tank.
- (3) An air or vacuum storage tank must be built so the service brake can be applied to meet the performance standards of rule 122 at least twice if the engine of the vehicle stops or the source of air or vacuum fails.
- (4) An air or vacuum storage system must —
  - (a) be built to give a visible or audible warning to the driver, while in a normal driving position, of a lack of air or vacuum that would prevent the service brake from being applied to meet the performance standards of rule 122 at least twice; and
  - (b) be safeguarded by a check valve or other device against loss of air or vacuum if the supply fails or leaks.
- (5) However, subrule (4)(a) does not apply to a vehicle with a GVM of 4.5 t or less that is fitted with an air or vacuum assisted braking system.
- (6) If air brakes or vacuum brakes are fitted to a motor vehicle equipped to tow a trailer, the brakes of the vehicle must be able to stop the vehicle, at the performance standards for emergency brakes under rule 122 if the trailer breaks away.

- (7) The braking system of a motor vehicle with a GVM over 4.5 t equipped to tow a trailer fitted with air brakes must include protection against loss of supply line air or brake control signal air.
- (8) The protection mentioned in subrule (7) must —
  - (a) operate automatically if a brake supply line hose connecting the motor vehicle and a trailer fails;
  - (b) maintain enough air pressure to allow the brakes to be applied to meet performance standards for emergency brakes under rule 122; and
  - (c) include a visible or audible warning to the driver.

### **Division 3 — Trailer braking systems**

#### **126. What brakes a trailer must have**

- (1) A trailer with a GTM over 750 kg must have brakes that operate on at least one wheel at each end of one or more axles of the trailer.
- (2) A semi-trailer or converter dolly with a GTM over 2 t must have brakes that operate on all its wheels.

#### **127. Operation of brakes on trailers**

- (1) The braking system of a trailer with a GTM over 2 t must allow the driver of a motor vehicle towing the trailer to operate the brakes from a normal driving position.
- (2) However, subrule (1) does not apply to an unloaded converter dolly that weighs under 3 t if the motor vehicle towing the converter dolly has a GVM over 12 t.
- (3) The brakes on a trailer with a GTM over 2 t must —
  - (a) operate automatically and quickly if the trailer breaks away from the towing vehicle;

- (b) remain in operation for at least 15 minutes after a break-away; and
- (c) be able to hold the trailer on a 12% gradient while in operation after a break-away.

**128. Air brakes or vacuum brakes on trailers**

- (1) If a trailer has air brakes, its braking system must include at least one air storage tank.
- (2) If a trailer has vacuum brakes, its braking system must include at least one vacuum storage tank.
- (3) An air or vacuum storage system must —
  - (a) be built to give a visible or audible warning to the driver of the towing vehicle, while in a normal driving position, of a lack of air or vacuum that would prevent the brakes from meeting the performance standards of rule 122; and
  - (b) be safeguarded by a check valve or other device against loss of air or vacuum if the supply fails or leaks.
- (4) Subrules (1), (2) and (3) do not apply to a trailer with a GTM of 2 t or less.

**Division 4 — Additional brake requirements for B-doubles and long road trains**

**129. Non-application of Division — certain road trains**

This Division does not apply to a road train or to a vehicle used in a road train, if the road train has a length of 19 m or less.

**130. Braking system design for a prime mover in a B-double**

- (1) A prime mover used in a B-double must comply with second edition ADR 35A or third edition ADR 35.

**r. 131**

---

- (2) A prime mover used in a B-double must also have an anti-lock braking system complying with third edition ADR 64, if the prime mover —
- (a) was built after 1989; and
  - (b) is used in a B-double that includes a road tank vehicle carrying dangerous goods.

**131. Braking system design for motor vehicles in road trains**

The performance of the service, secondary and parking brake systems of a motor vehicle used in a road train must comply with second edition ADR 35A or third edition ADR 35 if the vehicle would not otherwise be required to comply with an ADR about braking.

**132. Braking system design for trailers in B-doubles or road trains**

- (1) The performance of the service, secondary and parking brake systems of a trailer used in a B-double or road train must comply with second edition ADR 38 or third edition ADR 38 if the trailer would not otherwise be required to comply with an ADR about braking.
- (2) A road train trailer to which subrule (1) applies need not be fitted with a mechanical parking brake if it carries wheel chocks that provide a performance equal to the performance standard required for a parking brake system.
- (3) A semi-trailer, regardless of when it was built, must have an anti-lock braking system that complies with third edition ADR 38/01, if —
- (a) it is being used in a B-double that includes a road tank vehicle, whether or not the semi-trailer is itself a road tank vehicle; and
  - (b) the road tank vehicle is carrying dangerous goods.

**133. Air brakes of motor vehicles in B-doubles or road trains**

- (1) If a B-double or road train is fitted with brakes that operate using compressed air, the braking system of the motor vehicle must comply with subrules (2) and (3) when —
  - (a) the pressure is measured in an 800 mL vessel connected by a 2 m pipe with a bore of approximately 13 mm to the coupling head of the braking system; and
  - (b) the air pressure before the brakes are applied is not under —
    - (i) the average of the maximum and minimum pressures in the operating pressure range specified by the vehicle's manufacturer; or
    - (ii) if there is no manufacturer's specification — 650 kPa.
- (2) The pressure must reach at least 420 kPa within 400 milliseconds after the rapid and complete application of the foot-operated brake control.
- (3) After the brakes have been fully applied, the pressure must fall within half a second after the release of the foot-operated brake control to 35 kPa.

**134. Air brakes in a B-double or road train — least favoured chamber**

- (1) In this rule —  
**“least favoured chamber”** means the brake chamber with the longest line to the treadle valve in the prime mover.
- (2) The pressure in the least favoured chamber of the braking system of a B-double or road train with brakes that operate using compressed air must comply with subrules (3) and (4) when the air pressure before the brakes are applied is not under —
  - (a) the average of the maximum and minimum pressures in the operating pressure range specified by the vehicle’s manufacturer; or
  - (b) if there is no manufacturer’s specification — 650 kPa.
- (3) The pressure must reach at least 420 kPa within —
  - (a) for a B-double — one second after the rapid and complete application of the foot-operated brake control; or
  - (b) for a road train — 1.5 seconds after the rapid and complete application of the foot-operated brake control.
- (4) After the brakes have been fully applied, the pressure must fall to 35 kPa, or the pressure at which the friction surfaces cease to contact each other, within —
  - (a) for a B-double — one second after the release of the foot-operated brake control; or
  - (b) for a road train — 1.5 seconds after the release of the foot-operated brake control.



**135. Recovery of air pressure for brakes in B-doubles and road trains**

The air pressure in each air brake reservoir in a B-double or road train must recover to at least 420 kPa within one minute after 3 full brake applications have been made within a 10 second period if, before the 3 brake applications have been made —

- (a) the engine is running at maximum speed;
- (b) the governor cut-in pressure is no higher than —
  - (i) the pressure specified by the vehicle's manufacturer; or
  - (ii) if there is no manufacturer's specification — 550 kPa;

and

- (c) the air pressure in the storage tanks of the vehicle is not under —
  - (i) the average of the maximum and minimum pressures in the operating pressure range specified by the vehicle's manufacturer; or
  - (ii) if there is no manufacturer's specification — 650 kPa.

**136. Air supply for brakes in B-doubles and road trains**

A B-double or road train that uses compressed air to operate accessories must have —

- (a) sufficient air compressor capacity and air receiver volume to ensure that the operation of the accessories does not adversely affect brake performance; and
- (b) a compressed air system built to ensure that the brake system is preferentially charged.

**137. Brake line couplings**

- (1) Brake line couplings on the same part of a vehicle in a B-double or road train must not be interchangeable.
- (2) The couplings must be polarised in accordance with Australian Standard AS D8 — 1971 *Hose Couplings for Use with Vacuum and Air-Pressure Braking Systems on Prime Movers, Trailers and Semi-trailers* if the hoses used with the brake couplings are used for the same purpose as the hoses mentioned in the standard.

**138. Simultaneous parking brake application**

- (1) If the parking brake of a motor vehicle in a B-double or road train is applied, the parking brakes of any attached trailer must be applied automatically.
- (2) This rule does not apply to a trailer carrying wheel chocks complying with rule 132(2).

**139. Capacity of air reservoirs**

- (1) The capacity of the air storage tanks of a motor vehicle used in a B-double or road train must be at least 12 times the volume of all the brake activation chambers on the motor vehicle.
- (2) The capacity of the air storage tanks of a trailer used in a B-double or road train must be at least 8 times the volume of all the brake activation chambers on the trailer.

## **Part 10 — Control of emissions**

### **Division 1 — Crank case gases and visible emissions**

#### **140. Crank case gases**

- (1) This rule applies to a motor vehicle with 4 or more wheels that is powered by a petrol engine and was built after 1971.
- (2) The vehicle must be built to prevent, or fitted with equipment that prevents, crank case gases from escaping to the atmosphere.

#### **141. Visible emissions**

- (1) This rule applies to a motor vehicle that is propelled by an internal combustion engine and was built after 1930.
- (2) The vehicle must not emit visible emissions for a continuous period of at least 10 seconds.
- (3) However, this rule does not apply to emissions that are visible only because of heat or the condensation of water vapour.

### **Division 2 — Exhaust systems**

#### **142. Exhaust systems**

- (1) The outlet of the exhaust system fitted to a motor vehicle (except a bus) must extend —
  - (a) behind the back seat;
  - (b) at least 40 mm beyond the outermost joint of the floorpan that is not continuously welded or permanently sealed;
  - (c) to the edge of the vehicle, if —
    - (i) the body of the vehicle is permanently enclosed; and
    - (ii) the vehicle is not fitted with a vertical exhaust system;

- and
- (d) no further than the edge of the vehicle at its widest point.
- (2) The outlet must discharge the main exhaust flow to the air —
- (a) if the vehicle is fitted, or required to be fitted, with an exhaust system with a vertical outlet pipe —
- (i) at an angle above the horizontal;
- (ii) at least 150 mm above the cab of the vehicle; and
- (iii) rearwards or to the right of the vehicle;
- and
- (b) in any other case —
- (i) horizontally or at an angle of not over 45° downwards;
- (ii) under 750 mm above ground level; and
- (iii) rearwards or to the right of the vehicle.
- (3) An exposed section of a vertical exhaust system fitted to a motor vehicle (except a bus) with a GVM over 4.5 t must be positioned or shielded to prevent injury.
- (4) The outlet of the exhaust system fitted to a bus with a GVM over 4.5 t must —
- (a) be as near as practicable to the rear of the vehicle; and
- (b) extend no further than the edge of the bus at its widest point.
- (5) The outlet must discharge the main exhaust flow to the air —
- (a) if the bus is fitted, or required to be fitted, with an exhaust system with a vertical outlet pipe —
- (i) behind the passenger compartment;
- (ii) at an angle above the horizontal; and
- (iii) upwards or rearwards;
- and

- (b) in any other case —
  - (i) horizontally or at an angle of not over 45° downwards; and
  - (ii) rearwards or to the right of the vehicle.
- (6) A vertical exhaust system fitted to a motor vehicle with a GVM over 4.5 t must —
  - (a) if the vehicle is fitted with an exhaust system with a vertical outlet pipe that does not direct the main exhaust flow straight up — direct the flow rearwards at an angle within 0° to 45° of the longitudinal centre line of the vehicle; and
  - (b) if a rain cap is fitted to the outlet pipe — be installed so the hinge of the cap is at an angle of 90° (plus or minus 10°) to the longitudinal centre line of the vehicle when viewed from above.

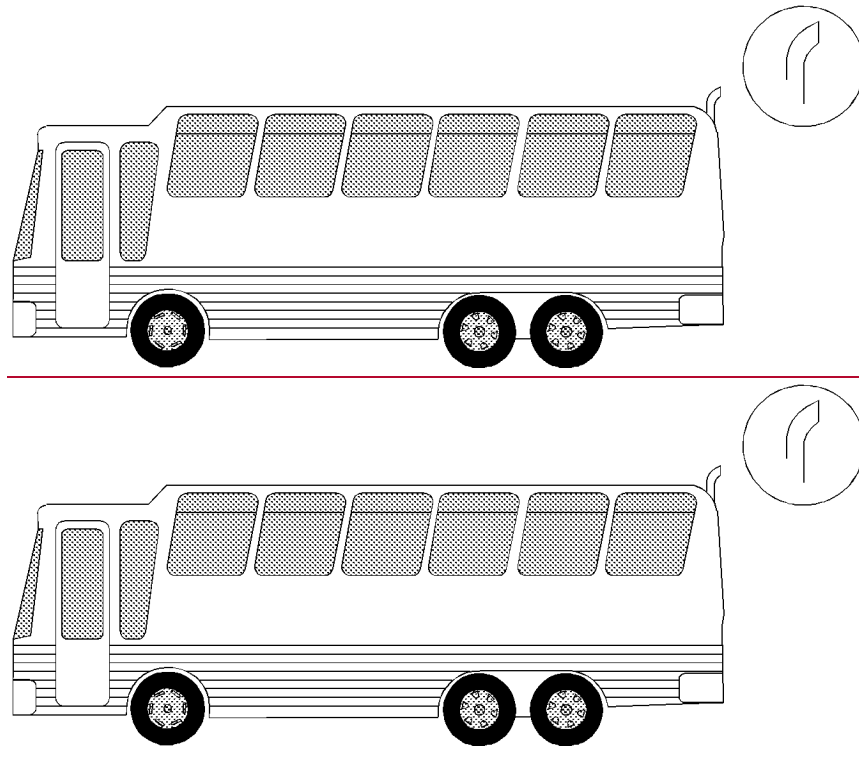

**Bus exhaust outlet pipe**

**Division 3 — Noise emissions**

**143. Silencing device for exhaust systems**

A motor vehicle propelled by an internal combustion engine must be fitted with a silencing device through which all the exhaust from the engine passes.

**144. Stationary noise levels — car-type vehicles and motor bikes and motor trikes**

- (1) In this rule —
- “*car-type vehicle*” means —
- (a) a car;

- (b) a utility truck, panel van or another motor vehicle derived from a car design; or
  - (c) another motor vehicle with 4 or more wheels that is built mainly to carry not over 9 people including the driver.
- (2) The stationary noise level of a car-type vehicle or motor bike or motor trike, must not exceed —
- (a) for a car-type vehicle built after 1982 — 90 dB(A);
  - (b) for another car-type vehicle — 96 dB(A);
  - (c) for a motor bike or motor trike built after February 1985 — 94 dB(A); or
  - (d) for another motor bike or motor trike — 100 dB(A).
- (3) However, this rule does not apply to a car-type vehicle built after 1982 for 2 years after the commencement of this rule, if —
- (a) the stationary noise level of the vehicle does not exceed 96 dB(A); and
  - (b) the stationary noise level limit applying to the vehicle under the law of the State or Territory where the vehicle is licensed or registered, or otherwise authorised to be driven on a road, is not 90 dB(A) or less.

**145. Stationary noise levels — other vehicles with spark ignition engines**

- (1) This rule applies to a motor vehicle (except a motor vehicle to which rule 144 applies) with a spark ignition engine.
- (2) The stationary noise level of the motor vehicle must not exceed the noise level applying to the vehicle under Table 2.

**Table 2**

<b>GVM (t)</b>	<b>Exhaust height (mm)</b>	<b>When vehicle built</b>	<b>Noise level (dB(A))</b>
≤3.5 .....	<1500 .....	Before July 1983 .....	92
		after June 1983 .....	89

<b>GVM (t)</b>	<b>Exhaust height (mm)</b>	<b>When vehicle built</b>	<b>Noise level (dB(A))</b>
>3.5 .....	<1500 .....	Before July 1983 .....	98
		after June 1983 .....	95
≤3.5 .....	≥1500 .....	Before July 1983 .....	88
		after June 1983 .....	85
>3.5 .....	≥1500 .....	Before July 1983 .....	94
		after June 1983 .....	91

**146. Stationary noise levels — other vehicles with diesel engines**

- (1) This rule applies to a motor vehicle (except a motor vehicle to which rule 144 applies) with a diesel engine.
- (2) The stationary noise level of the motor vehicle must not exceed the noise level applying to the vehicle under Table 3.

**Table 3**

<b>GVM (t)</b>	<b>Exhaust height (mm)</b>	<b>When vehicle built</b>	<b>Noise level (dB(A))</b>
≤3.5 .....	<1500 .....	before July 1980 .....	105
		after June 1980 but	
		before July 1983 .....	102
		after June 1983 .....	99
>3.5 but ≤12 ..	<1500 .....	before July 1980 .....	107
		after June 1980 but	
		before July 1983 .....	104
		after June 1983 .....	101
>12 .....	<1500 .....	before July 1980 .....	109
		after June 1980 but	
		before July 1983 .....	106
		after June 1983 .....	103
≤3.5 .....	≥1500 .....	before July 1980 .....	101



<b>GVM (t)</b>	<b>Exhaust height (mm)</b>	<b>When vehicle built</b>	<b>Noise level (dB(A))</b>
		after June 1980 but before July 1983 .....	98
		after June 1983 .....	95
>3.5 but ≤12 ..	≥1500 .....	before July 1980 .....	103
		after June 1980 but before July 1983 .....	100
		after June 1983 .....	97
>12 .....	≥1500 .....	before July 1980 .....	105
		after June 1980 but before July 1983 .....	102
		after June 1983 .....	99

**147. Measurement of stationary noise levels**

For this Division, the stationary noise level of a motor vehicle is to be measured in accordance with the test method mentioned in the *Roadworthiness Guidelines* that are approved by the Ministerial Council for Road Transport established by the Heavy Vehicles Agreement, a copy of which is set out in Schedule 1 to the *National Road Transport Commission Act 1991* of the Commonwealth, and current at the commencement of this rule.

## **Part 11 — LPG fuel systems**

### **148.    LPG-powered vehicles**

- (1) A motor vehicle equipped to run on LPG must comply with the requirements for the use of LPG in vehicles in —
  - (a) the version of Australian Standard AS 1425 — 1999 in force at the commencement of this rule; or
  - (b) if an earlier version of the standard was current when the vehicle was first equipped to run on LPG — that version.
  
- (2) A vehicle equipped to run on LPG must have fixed conspicuously to the front and rear number plates a label that is —
  - (a) made of durable material;
  - (b) at least 25 mm wide and 25 mm high;
  - (c) reflective red conforming to Australian Standard AS 1742 — 1975 *Manual of Uniform Traffic Control Devices*, Appendix C, Class 2; and
  - (d) marked 'LPGAS' or 'LPG', or with words or acronyms to similar effect, in capital letters at least 6 mm high.

---

## **Part 12 — Maximum road speed limiting**

### **149. Speed limiting**

- (1) A bus with a GVM over 14.5 t that was built after 1987 must comply with third edition ADR 65.
- (2) A prime mover with a GVM over 15 t that was built after 1987 must comply with third edition ADR 65.
- (3) For third edition ADR 65, the maximum road speed capability of a motor vehicle used in a road train is 100 km/h.

### **150. Exemptions from speed limiting**

Rule 149 does not apply to —

- (a) an emergency vehicle;
- (b) a bus fitted with hand grips or similar equipment for standing passengers to hold; or
- (c) a 2-axle prime mover if —
  - (i) it was built after 1987 but before July 1991; and
  - (ii) ~~its owner~~[the responsible person for it](#) is a person who uses it for agriculture, horticulture or other primary production activities (except forestry, fishing and mining).

---

*[Regulation 150 amended in Gazette 23 Dec 2005 p. 6280.]*

## **Part 13 — Mechanical connections between vehicles**

### **Division 1 — Couplings on all types of vehicles**

#### **151. General coupling requirements**

- (1) A fifth wheel coupling, the mating parts of a coupling, a kingpin or a towbar must not be used for a load more than the manufacturer's load rating.
- (2) A kingpin must be used only with a fifth wheel coupling that has a corresponding jaw size.
- (3) The mating parts of a coupling used to connect a semi-trailer to a towing vehicle must not allow the semi-trailer to roll to an extent that makes the towing vehicle unstable.

#### **152. Drawbar couplings**

- (1) A coupling for attaching a trailer, except a semi-trailer or pole-type trailer, to a towing vehicle must be built and fitted so —
  - (a) the coupling is equipped with a positive locking mechanism; and
  - (b) the positive locking mechanism can be released regardless of the angle of the trailer to the towing vehicle.
- (2) If the trailer is in a combination and is not fitted with breakaway brakes in accordance with rule 127(3), it must be connected to the towing vehicle by at least one chain, cable or other flexible device, as well as the coupling required by subrule (1).
- (3) The connection must be built and fitted so —
  - (a) the trailer is kept in tow if the coupling breaks or accidentally detaches; and
  - (b) normal angular movement of the coupling is permitted without unnecessary slack.

- (4) If practicable, the connection must be built and fitted so the drawbar of the trailer is prevented from hitting the ground if the coupling accidentally detaches.

**Division 2 — Additional coupling requirements for B-doubles and long road trains**

**153. Non-application of Division — certain road trains**

This Division does not apply to a vehicle, coupling, or part of a coupling, used in a road train not over 19 m long.

**154. Couplings for B-doubles and road trains**

- (1) A fifth wheel coupling used to connect a towing vehicle to a semi-trailer used in a B-double or road train must not be built with a pivot that allows a semi-trailer to roll relative to the towing vehicle.
- (2) However, subrule (1) does not apply to a fifth wheel coupling if —
- (a) the semi-trailer design requires torsional stresses to be minimised;
  - (b) the roll axis of the fifth wheel coupling is above the surface of the coupler plate; and
  - (c) the degree of rotation allowed around the roll axis of the fifth wheel coupling is restricted to prevent roll instability.
- (3) A trailer with only one axle group or a single axle (except a semi-trailer or a converter dolly) that is used in a road train must not have a coupling fitted at its rear.

**155. Selection of fifth wheel couplings for B-doubles and road trains**

- (1) A fifth wheel coupling used in a B-double or road train must have a D-value complying with Australian

**Road Traffic (Vehicle Standards) Rules 2002**

**Part 13** Mechanical connections between vehicles

**Division 2** Additional coupling requirements for B-doubles and long road trains

**r. 156**

---

Standard AS 1773 — 1990 *Articulated Vehicles — Fifth Wheel Assemblies*.

- (2) A turntable used in a B-double or road train must have a D-value complying with Australian Standard AS 1773 — 1990 *Articulated Vehicles — Fifth Wheel Assemblies*.
- (3) If a fifth wheel coupling used in a B-double or road train is built for a 50 mm kingpin or 90 mm kingpin, the coupling must —
  - (a) meet the dimension requirements in Australian Standard AS 1773 — 1990 *Articulated Vehicles — Fifth Wheel Assemblies*; and
  - (b) not be worn away more than recommended by the standard.
- (4) If a fifth wheel coupling used in a B-double or road train is built for a 75 mm kingpin, the coupling must —
  - (a) be compatible with the kingpin mentioned in rule 159(3); and
  - (b) not be worn away so that it does not comply with rule 156.

**156. D-value of a fifth wheel coupling**

In testing a fifth wheel coupling built for a 75 mm kingpin used in a B-double or road train to decide whether its D-value complies with rule 155(1), the longitudinal movement (after readjusting the jaws of the coupling using a kingpin built to the dimensions mentioned in rule 159(3)(a)) must not be over 4 mm.

**157. Mounting of fifth wheel couplings on B-doubles and road trains**

A fifth wheel coupling must be mounted on a prime mover or a semi-trailer used in a B-double or road train in accordance with Australian Standard AS 1771 — 1987 *Installation of Fifth Wheel and Turntable Assemblies*.

**158. Branding of fifth wheel couplings and turntables on B-doubles and road trains**

- (1) A fifth wheel coupling on a vehicle built after June 1991 forming part of a B-double or road train must be clearly and permanently marked in accordance with Australian Standard AS 1773 — 1990 *Articulated Vehicles — Fifth Wheel Assemblies* with —
  - (a) the name or trademark of its manufacturer;
  - (b) its D-value rating; and
  - (c) its nominal size.
- (2) A turntable used in a vehicle built after the commencement of this rule that forms part of a B-double or road train must be marked with —
  - (a) the name or trademark of the turntable's manufacturer; and
  - (b) the D-value rating of the turntable in accordance with Australian Standard AS 1773 — 1990 *Articulated Vehicles — Fifth Wheel Assemblies*.

**159. Selection of kingpins for B-doubles and road trains**

- (1) A kingpin used in a B-double or road train must —
  - (a) be a 50 mm kingpin, 75 mm kingpin or 90 mm kingpin; and
  - (b) have a D-value complying with Australian Standard AS 2175 — 1990 *Articulated Vehicles — Kingpins*.
- (2) A 50 mm kingpin or 90 mm kingpin used in a B-double or road train must —
  - (a) be built to meet the dimension requirements in Australian Standard AS 2175 — 1990 *Articulated Vehicles — Kingpins*; and
  - (b) not be worn away more than recommended by the standard.

**Road Traffic (Vehicle Standards) Rules 2002**

**Part 13** Mechanical connections between vehicles

**Division 2** Additional coupling requirements for B-doubles and long road trains

**r. 159**

---

- (3) A 75 mm kingpin used in a B-double or road train must —
- (a) be built to meet the dimensions in the following essential diagram; and
  - (b) not be worn away more than mentioned in subrule (4).



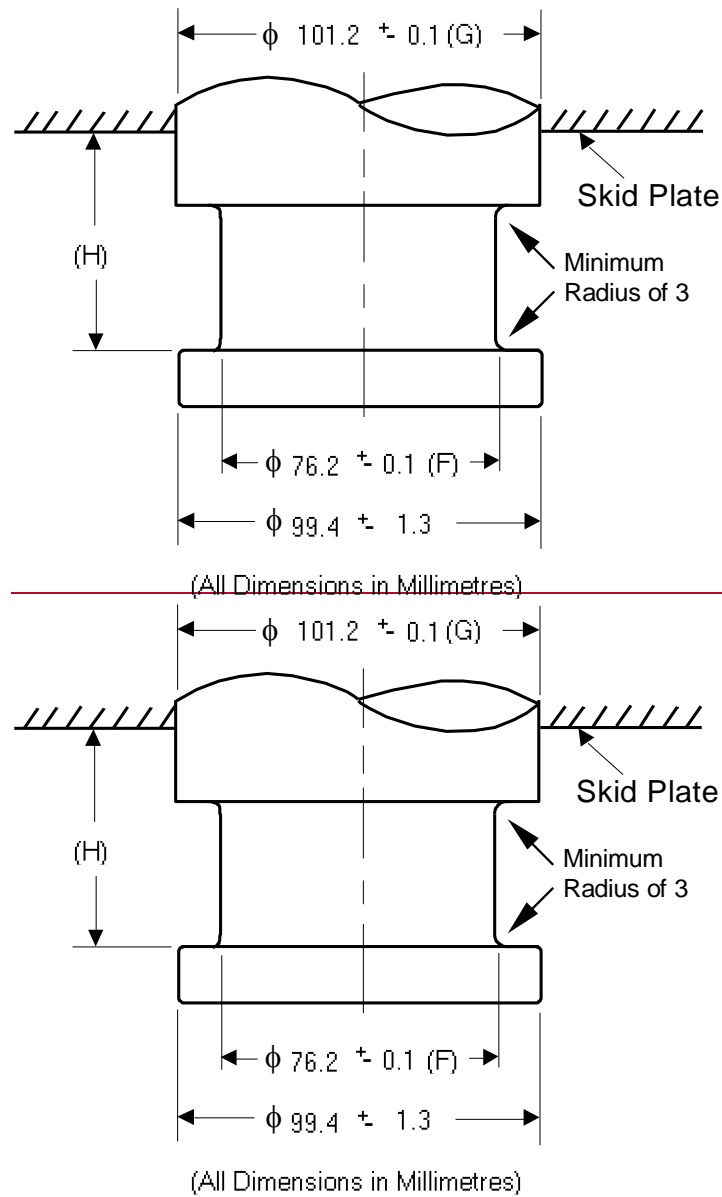

**Dimensions of a 75 mm kingpin**

- (4) In testing a 75 mm kingpin mentioned in the essential diagram in subrule (3) to decide whether its D-value complies with subrule (1)(b) —

**Road Traffic (Vehicle Standards) Rules 2002**

**Part 13** Mechanical connections between vehicles

**Division 2** Additional coupling requirements for B-doubles and long road trains

**r. 160**

---

- (a) diameter F must not wear more than 3 mm;
- (b) diameter G must not wear more than 2 mm; and
- (c) height H must not wear more than 2.3 mm.

**160. Attachment of kingpins on B-doubles and road trains**

A kingpin used in a trailer that forms part of a B-double or road train must be attached in accordance with —

- (a) the manufacturer's specifications and instructions; or
- (b) the guidelines detailed in Australian Standard AS 2175 — 1990 *Articulated Vehicles — Kingpins*.

**161. Branding of kingpins on B-doubles and road trains**

A kingpin used in a trailer built after June 1991 that forms part of a B-double or road train must be clearly and permanently marked on the lower circular face of the kingpin in accordance with Australian Standard AS 2175 — 1990 *Articulated Vehicles — Kingpins* with —

- (a) the name or trademark of its manufacturer;
- (b) its D-value rating; and
- (c) its nominal size.

**162. Selection of couplings and drawbar eyes for road trains**

A drawbar-type coupling or drawbar eye used in a road train must —

- (a) be a 50 mm pin type;
- (b) have a D-value complying with Australian Standard AS 2213 — 1984 *50 mm Pin Type Couplings and Drawbar Eyes for Trailers*;
- (c) be built to the dimensions mentioned in the standard; and
- (d) not be worn away more than is recommended in the standard.

**163. Attachment of couplings and drawbar eyes on road trains**

A drawbar-type coupling or drawbar eye used in a road train must be built and positioned so —

- (a) when the road train is moving, the drawbar can move at least 15° upwards or downwards from the position it occupies when the road train is parked on level ground;
- (b) the pivot point of the coupling is not over 300 mm forward of the rear of the trailer to which it is attached; and
- (c) it is at a height of at least 800 mm, but not over 950 mm, when the road train is unloaded and parked on level ground.

**164. Branding of couplings and drawbar eyes on road trains**

A drawbar-type coupling or drawbar eye used on a vehicle built after June 1991 that forms part of a road train must be clearly and permanently marked in accordance with Australian Standard AS 2213 — 1984 *50 mm Pin Type Couplings and Drawbar Eyes for Trailers* with —

- (a) the name or trademark of its manufacturer; and
- (b) its D-value rating.

**165. Tow coupling overhang on road trains**

- (1) In this rule —

**“*tow coupling overhang*”** of a vehicle means the horizontal distance from the centre of the axle group, or the centre of the single axle, at the rear of the vehicle to the pivot point of the coupling near the rear of the vehicle.

- (2) The tow coupling overhang of a motor vehicle, except a prime mover, used in a road train must not be more than the greater of —

**Road Traffic (Vehicle Standards) Rules 2002**

**Part 13** Mechanical connections between vehicles

**Division 2** Additional coupling requirements for B-doubles and long road trains

**r. 165**

---

- (a) 30% of the distance from the centre of the front axle to the centre of the axle group or single axle at the rear of the vehicle; and
  - (b) 2.7 m.
- (3) The tow coupling overhang of a semi-trailer, or a dog trailer consisting of a semi-trailer and converter dolly, used in a road train must not be more than 30% of the distance from the point of articulation to the centre of the axle group or single axle at the rear of the vehicle.
- (4) The tow coupling overhang of another dog trailer used in a road train must not be more than 30% of the distance from the centre of the front axle group or single axle to the centre of the axle group or single axle at the rear of the vehicle.

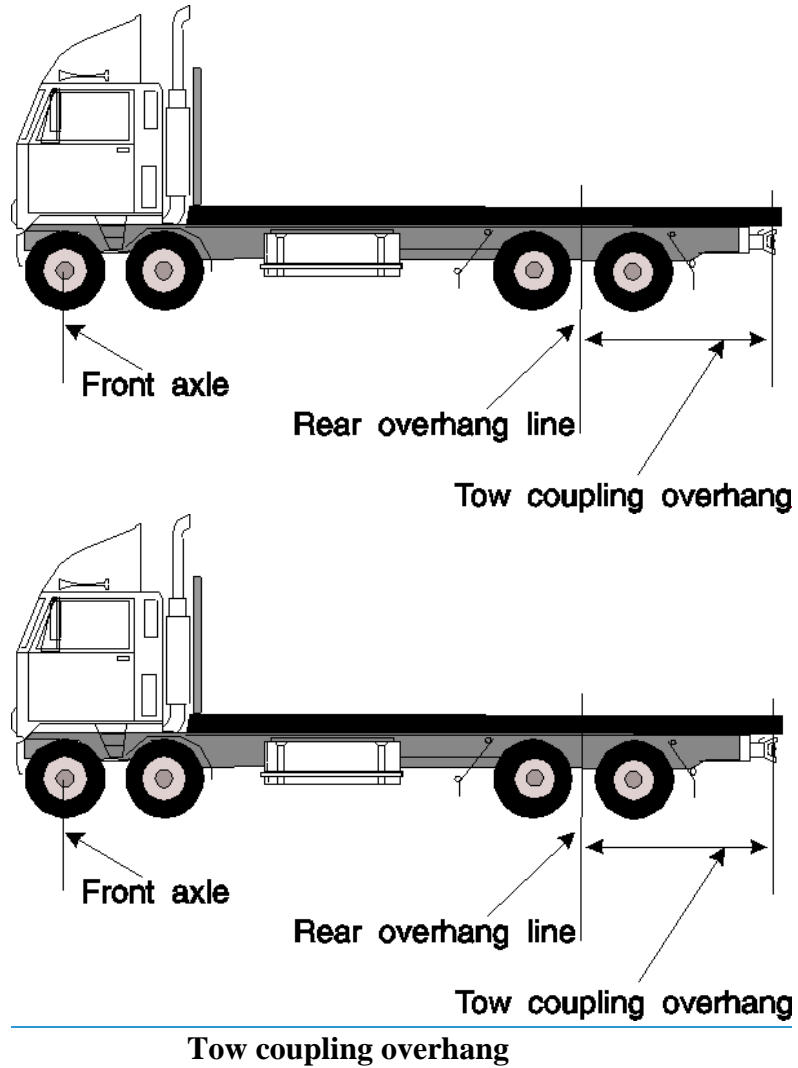

**Road Traffic (Vehicle Standards) Rules 2002**

**Part 13** Mechanical connections between vehicles

**Division 2** Additional coupling requirements for B-doubles and long road trains

**r. 165**

---

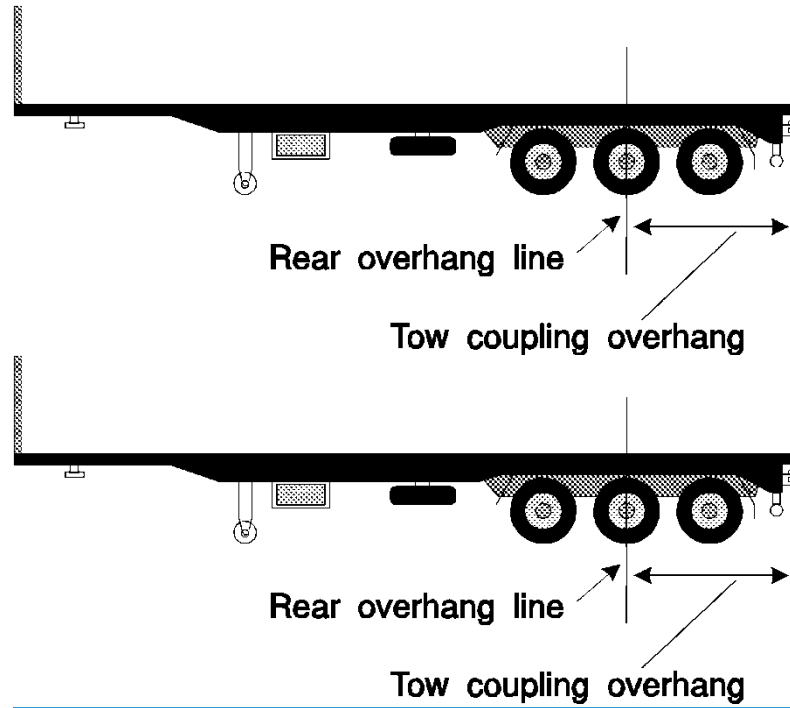

**Tow coupling overhang —  
semi-trailer with extra coupling at rear**

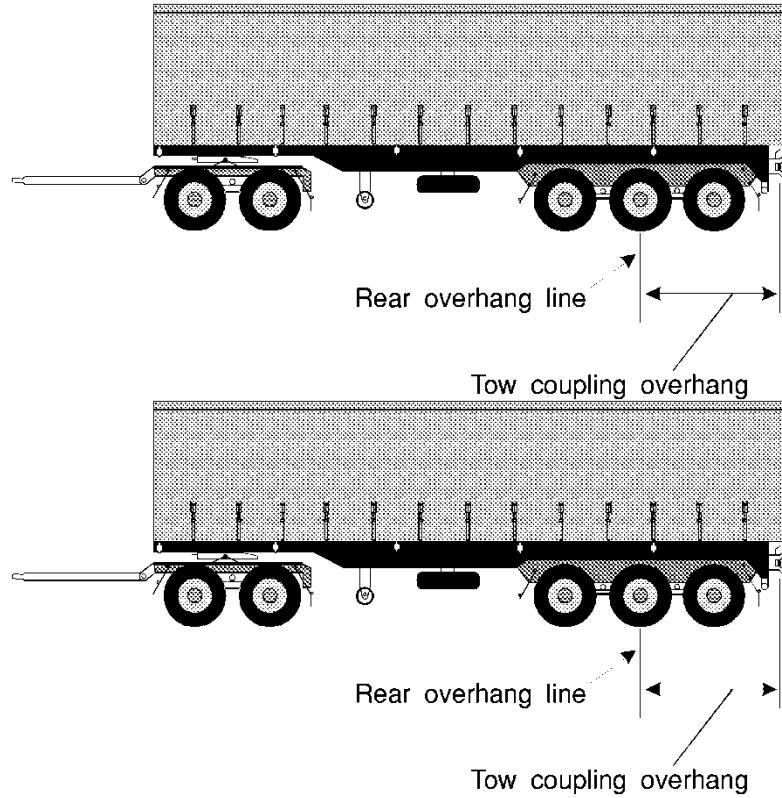

**Tow coupling overhang — dog trailer**

## Part 14 — Other matters

### 166. Vehicle equipment

A vehicle is taken to have equipment mentioned in the Vehicle Standards only if the equipment is in working order.

### 167. Restored vehicles

- (1) For the Vehicle Standards, a restored vehicle is taken to have been built when it was originally built and not when it was restored.
- (2) In this rule —  
**“restored vehicle”** means a vehicle that is being, or has been, restored to its manufacturer’s specifications, so far as it is practicable to meet the specifications.

### 168. Retractable axles

- (1) For the Vehicle Standards, a retractable axle is taken to be an axle only when it is in the lowered position.
- (2) In this rule —  
**“retractable axle”** means an axle with a means of adjustment enabling it to be raised or lowered relative to the other axles in the axle group.

### 169. Measurement of distance between parallel lines

For the Vehicle Standards, a distance between 2 parallel lines is measured at right angles between the lines.

### 170. Interpretation of certain second edition ADRs

The words **“left”** and **“right”** in the following second edition ADRs have the opposite meaning in the application of the ADRs, in accordance with the Vehicle Standards, to a motor vehicle with a left-hand drive —

- (a) ADR 8 Safety Glass;
- (b) ADR 12 Glare Reduction in Field of View;



- (c) ADR 14 Rear Vision Mirrors;
- (d) ADR 16 Windscreen Wipers and Washers;
- (e) ADRs 18 and 18A Location and Visibility of Instruments;
- (f) ADRs 35 and 35A Commercial Vehicle Braking Systems.

Note: The following Table lists some terms used in the third edition ADRs and the corresponding term used in the Vehicle Standards.

<b>Third edition ADRs</b>	<b>Vehicle Standards</b>
dipped-beam headlamp .....	low-beam (for a headlight)
front fog lamp.....	Front fog light
rear fog lamp .....	rear fog light
Wheelguard .....	Mudguard
main-beam headlamp .....	high-beam (for a headlight)
reversing lamp .....	Reversing light
direction indicator lamp .....	Direction indicator light
stop lamp .....	Brake light
rear registration plate lamp .....	Number plate light
front position (side) lamp .....	Parking light
rear position (side) lamp .....	tail light
end-outline marker lamp .....	Front or rear clearance light
external cabin lamp.....	External cabin light
internal lamp .....	Interior light
side marker lamp .....	side marker light
daytime running lamp .....	Daytime running light
rear reflex reflector, non-triangular.....	rear reflector
front reflex reflector, non-triangular.....	front reflector
side reflex reflector, non-triangular .....	side reflector

## **Part 15 — Additional Western Australian provisions**

### **Division 1 — Omnibuses**

#### **171. Passengers on omnibus with minimum 1.5 m interior height**

- (1) This rule applies to an omnibus with an interior height of 1.5 m or more.
- (2) The maximum number of passengers that an omnibus is permitted to carry is the least of the following —
  - (a) the number equal to the total number of seating and standing positions recommended for the omnibus by the manufacturer;
  - (b) the greatest number that does not permit the potential loaded mass of the omnibus to exceed its GVM; or
  - (c) if the number that is the lesser of paragraphs (a) and (b) is likely to jeopardise the safety of the passengers in circumstances in which the omnibus is likely to be used — the greatest number compatible with promoting the safety of those passengers, as determined by the Director General.
- (3) The potential loaded mass of an omnibus is the amount, in kilograms, equal to M in the formula —

$$\del M = (P \times L) + T$$

$$M = (P \times L) + T$$

where —

P is the number of standing and seating positions recommended for the omnibus by the manufacturer;

L is —

- (a) if provision is made on the omnibus for hand luggage and other luggage — 80;

- (b) if no provision is made on the omnibus for any luggage except hand luggage — 65;

T is the unloaded mass of the omnibus.

- (4) The number of passengers an omnibus is permitted to carry under subrule (2) must be clearly displayed on the interior of the omnibus in letters and numerals that are at least 25 mm in height.

*[Rule 171 amended in Gazette 27 Jul 2004 p. 3083.]*

**172. Passengers on omnibus with less than 1.5 m interior height**

- (1) This rule applies to an omnibus with an interior height of less than 1.5 m.
- (2) The total number of passengers that an omnibus is permitted to carry is the adult seating capacity of that omnibus.
- (3) The number of passengers an omnibus is permitted to carry under subrule (2) must be clearly displayed on the interior of the omnibus in letters and numerals that are at least 25 mm in height.

**173. Standing positions and equipment**

- (1) A standing position on an omnibus must be floor space with the following qualities —
- (a) the floor space must be rearward of the driver's seat;
  - (b) there must be a handhold that is easily accessible to a person standing in that floor space;
  - (c) the floor space must be greater than 380 mm in width and length;
  - (d) the floor must be of a gradient less than 1:16;
  - (e) the floor must not be part of any step at a doorway or an area within the opening radius of a door;
  - (f) the floor space must be at least 200 mm in front of any seat cushions.

**Road Traffic (Vehicle Standards) Rules 2002**

**Part 15** Additional Western Australian provisions

**Division 1** Omnibuses

**r. 173**

---

- (2) Floor space for a wheelchair may be regarded as one or more “standing positions” if it is not being occupied by a wheelchair.

- (3) Handholds must satisfy the following criteria —
- (a) there must be at least one for each nominated standing position;
  - (b) the handhold must be in the form of a handrail, a seat “corner grip”, a stirrup-type strap, a stanchion or an overhead hand strap, all of which are subject to the approval of the Director General;
  - (c) the handholds must be on either side of the omnibus and, in the Director General’s opinion, readily accessible to a passenger in a standing position to which the handhold relates;
  - (d) the Director General must be of the opinion that the handholds are safe, sufficiently supportive and are associated with appropriate floor space.

**174. Destination signs**

When an omnibus other than a school bus is plying for hire, the name of its destination —

- (a) must be clearly and conspicuously exhibited on the destination sign fitted to the omnibus; and
- (b) must be capable of being read, in the daytime or when illuminated at night-time, at a distance of 27 m.

**175. School bus exterior colours and signs**

The exterior of a school bus —

- (a) must be painted in a predominantly orange colour relieved with green on the body, with the roof painted cream or white; and
- (b) must have the words “SCHOOL BUS” conspicuously painted on both the front and rear, in letters of not less than 100 mm in height, unless the school bus is fitted with warning lights or signs under Part 8 Division 18.

**175A. First aid kit on non-metropolitan omnibus**

An omnibus operating on a route all or most of which lies outside the metropolitan area (as defined in section 18B of the *Transport Co-ordination Act 1966*) must be equipped with a comprehensive and serviceable first aid kit, carried in a position on the vehicle so as to be readily available for use.

*[Rule 175A inserted in Gazette 3 Jan 2003 p. 4-5.]*

**Division 2 — Miscellaneous**

**176. Required immobilisers**

- (1) A motor vehicle in relation to which an application is made for the grant or transfer of the licence for the vehicle must be fitted with one of the following immobilisers —
  - (a) an immobiliser fitted to a vehicle by the manufacturer of the vehicle or a person authorised by the manufacturer, at the time the vehicle is being manufactured;
  - (b) an immobiliser that complies with Part III (“Approval of immobilisers and approval of a vehicle with regard to its immobiliser”) of ECE 97 “Vehicle Alarm Systems” published by the United Nations Economic Commission for Europe;
  - (c) an immobiliser fitted to a vehicle as an integral part of an alarm system complying with AS/NZS 3749.1:1997 “Intruder alarm systems — Road vehicles”, jointly published by Standards Australia and Standards New Zealand;
  - (d) an immobiliser that complies with AS/NZS 4601:1999 “Vehicle immobilisers”, jointly published by Standards Australia and Standards New Zealand;
  - (e) an immobiliser —
    - (i) fitted to a vehicle before 1 July 1999; and
    - (ii) that is self-arming and immobilises the engine either by interrupting the fuel, ignition, starter or engine management system;

- (f) an immobiliser —
    - (i) fitted to a vehicle before 1 January 2001; and
    - (ii) that complies with “Specifications for Vehicle Immobiliser” published by the Department of Transport on 4 August 2000 and available from its Vehicle Safety Branch at 21 Murray Road South, Welshpool WA 6106;
  - (g) a device known as the “GT2000 Gearlock Auto-armed Pinlock”, manufactured by “Grip-Tech (Pty) Ltd”, that is fitted to a vehicle in accordance with the manufacturer’s instructions.
- (2) If a vehicle is required under subrule (1) to be fitted with a prescribed immobiliser at the time an application is made, that requirement continues in force from that time.
- (3) Except as stated in subrule (4), this regulation applies to a car, an omnibus or a goods vehicle.
- (4) This rule does not apply to a motor vehicle —
- (a) with an unloaded mass of 3 t or more;
  - (b) with a GVM of more than 4.5 t;
  - (c) built 25 years or more before the time the application for the grant or transfer of the licence for the vehicle is made;
  - (d) in relation to which an application has been made —
    - (i) for the grant or transfer of a licence referred to in section 76C(6) or (6a) of the *Stamp Act 1921*; or
    - (ii) for the transfer of a licence under a judgment or order of a court;
- or
- (e) to which regulation 21D of the *Road Traffic (Licensing) Regulations 1975* applies.

**177. Fitting of illuminated signs**

- (1) In addition to the lights prescribed or permitted under Part 8 —

- (a) an omnibus may be equipped with a light or lights for lighting a sign indicating the route, destination or other necessary information relating to the omnibus;
  - (b) a motor vehicle, licensed for the carriage of not more than 8 passengers for hire or reward, may be equipped with a light or lights for the lighting of any sign authorised or required to be displayed on the vehicle by any enactment relating to taxi-cars;
  - (c) a vehicle that is —
    - (i) an emergency vehicle; or
    - (ii) a motor breakdown service vehicle,may be equipped with a light or lights for lighting a sign ordinarily displayed by that vehicle; and
  - (d) any other vehicle may be equipped with a light or lights for lighting a sign on that vehicle if the sign —
    - (i) is mounted on the roof of the vehicle or on a bar across the roof; and
    - (ii) is fitted with no more than 2 globes each of 7 W or less.
- (2) Lights fitted to a vehicle referred to in subrule (1)(c) for the purpose of illuminating a sign may be fitted so as to have the capacity to display intermittent flashes when other flashing warning lights fitted to that vehicle are activated but not otherwise.
- (3) Lights fitted to a vehicle referred to in subrule (1)(b) for the purpose of illuminating a sign may be fitted so as to have the capacity to display intermittent flashes in the circumstances prescribed under regulation 289 of the *Road Traffic Code 2000*.

**178. Compliance plates**

If an ADR other than a third edition ADR applies to the design and construction of a vehicle, the vehicle is to be fitted with a plate approved by the Australian Motor Vehicle Certification Board indicating compliance with the ADR.



**Notes**

- <sup>1</sup> This is a compilation of the *Road Traffic (Vehicle Standards) Rules 2002* and includes the amendments made by the other written laws referred to in the following table.

**Compilation table**

<b>Citation</b>	<b>Gazettal</b>	<b>Commencement</b>
<i>Road Traffic (Vehicle Standards) Rules 2002</i>	12 Aug 2002 p. 4033-148	1 Nov 2002 (see r. 2)
<i>Road Traffic (Vehicle Standards) Amendment Rules 2002</i>	3 Jan 2003 p. 3-5	3 Jan 2003
<i>Road Traffic (Vehicle Standards) Amendment Rules 2004</i>	27 Jul 2004 p. 3083	27 Jul 2004
<a href="#"><u><i>Road Traffic (Vehicle Standards) Amendment Rules 2005</i></u></a>	<a href="#"><u>23 Dec 2005 p. 6280</u></a>	<a href="#"><u>1 Jan 2006 (see r. 2 and <i>Gazette</i> 23 Dec 2005 p. 6244-5)</u></a>