



Western Australia

# **Metropolitan Water Supply, Sewerage and Drainage By-laws 1981**

**Reprinted as at 5 May 2000**



# Metropolitan Water Supply, Sewerage and Drainage By-laws 1981

---

## CONTENTS

---

### **Preliminary and definitions**

1.0	Citation	1
1.1	Interpretation	1
1.2	Definitions in AS/NZS 3500 apply	7
1.3	Variations from definitions in AS/NZS 3500	7
1.4	Inconsistency of definitions	8

### **2.0 Protection of the Board's works and property**

2.1	General	9
2.2	Protection of works	9
2.3	Protection of grounds	10

### **3. Protection of water against pollution**

3.1	General	13
3.2	Protection of water purity	13

### **4. Protection of catchment areas and water reserves**

4.1	General	15
4.2	Application	15
4.3	Protection of water quality	16
4.4	Disposal of sewage and waste	17
4.5	Control of animals, livestock, etc.	18
4.6	Chemicals and flammable liquids	20

Contents

---

4.7	Protection of water from turbidity	21
4.8	Control of development	22
4.9	Restoration after commission of an offence	23
4.10	Control of persons and vehicles	23
<b>5.0 Protection of public water supply areas and underground water pollution control areas</b>		
5.1	General	25
5.2	Control of private wells	25
5.3	Protection of Board works	27
5.4	Protection of underground water quality	27
5.5	Control of development	29
5.6	Protection of pollution areas	33
<b>6.0 Supply of water and the installation of services and meters</b>		
6.1	General	43
6.2	Supply and use of water	43
6.3	Services to rated properties	45
6.4	Non-rated services	47
6.5	Building services	50
6.6	Water for cooling and hydraulically operated machines	52
6.7	Meters	52
<b>7.0 Water supply plumbing</b>		
7.1	Water supply plumbing to comply with standards	57
7.2	Manufacturer's specifications not to be exceeded	61
7.3	Installation of concealed pipes	61
<b>8.0 Water supply plumbing materials</b>		
<b>11.0 Storage tanks for cold water</b>		
11.1	Definition	64
11.2	Storage tanks required	64
<b>12.0 Joint water supply system</b>		
12.1	Definition "joint water supply system"	66

12.2	Joint water supply system isolating valve	66
12.3	Dwelling unit isolating valve	66
12.4	Common facilities isolating valve	66
12.5	Provision for metering	66
<b>13.0 Fire services</b>		
13.1	Fire hose reel installations	68
<b>14.0 Domestic hot water systems</b>		
14.2	Installation of heater	69
14.4	Cold water supply	69
<b>15.0 Private water supply systems</b>		
15.1	Pipes and apparatus for private services	71
15.2	Separate services required	71
15.3	Notice of intention to build	72
15.4	Water for cooling purposes	72
15.8	Maintenance of private services and interference with meters etc.	74
15.9	Ornamental fountains and swimming pools	75
<b>16.0 Sanitary and drainage plumbing</b>		
16.1	Sanitary and drainage plumbing to comply with standard	77
16.2	Manufacturer's specifications not to be exceeded	80
<b>18.0 Connection of fixtures and fittings</b>		
18.2	Air-conditioners and plant-rooms	82
18.3	Arrestors	82
18.20	Swimming pools	83
18.23	Washing machines	83
<b>19.0 Water supply to sanitary fixtures</b>		
19.3	Flushing systems	85
<b>25.0 Property sewerage design and installation</b>		
25.7	Excavation, bedding and property sewer installation	87

	<b>26.0 Jointing of pipes</b>	
26.4	Materials and methods of jointing pipes and fittings	89
	<b>27.0 Sewerage services — general</b>	
27.1	Procedure for connections to sewer	90
27.2	Proof of connections having been made. Certificate of Corporation's officer	90
27.3	Plans required for property sewerage installation and fees for examination of plans	90
27.4	Diagram of existing property sewers	92
27.5	Plan to be available to the Corporation	93
27.6	Notice and plan of intended new building or additions etc. to existing building	93
27.8	Use of property sewers	94
27.9	Sewerage services to non-rateable properties	96
	<b>28.0 Industrial wastes</b>	
28.1	Conditions of Discharge	97
28.2	Connections prior to by-law	103
28.3	Polluted areas	104
28.4	Prohibited discharges	109
28.5	Subsoil water	129
28.6	Materials and fittings used in connection with the Corporation's works	129
28.7	Basement and cellar drainage	132
28.8	Safes and overflows	134
28.9	Plumbing general	136
	<b>30.0 Licences and permits</b>	
30.1	Persons who may carry out water supply plumbing	143
30.2	Persons who may carry out sanitary plumbing	143
30.2A	Persons who may carry out drainage plumbing	144
30.3	Penalties for doing work without a water supply or sanitary plumber's licence	144
30.4	Description and scope of licences	144
30.5	Conditions of licence	145
30.6	Licence fees	147
30.7	Renewal of licences	147
30.8	List of licensed plumbers shall be published	147

30.9	Notices, applications, permits, and inspection of works	148
30.10	Water supply plumbers	158
30.11	Water supply and sanitary plumbers	159
30.11A	Drainage plumbers	160
30.12	Applicants holding licences from overseas authorities	160
30.13	Persons authorized to carry out plumbing work under direction and supervision	160
30.14	Registration of certificates of persons provided for in by-law 30.13	161
30.16	Damage to pipes shall be reported	162
30.17	Statement to be signed	163
30.18	Change of address shall be notified	163
30.19	Penalties for breaches of by-laws by plumbers	163

**31.0 Offences and penalties**

31.1	Gratuities prohibited	165
31.2	Junction or interference with pipes, sewers, or fittings	165
31.3	Obstruction of sewers and main drains	165
31.4	Penalties	165
31.5	Authority to enter premises	166
31.6	Period for compliance with notices	167

**32.0 Miscellaneous**

32.1	Standard drawings for fixtures and fittings	168
------	---	-----

**Schedule B**

**Schedule C — Fees**

**Schedule D**

**Notes**

**Defined Terms**







Western Australia

Reprinted under the  
*Reprints Act 1984* as  
at 5 May 2000

Metropolitan Water Supply, Sewerage, and Drainage Act 1909<sup>1a</sup>

## Metropolitan Water Supply, Sewerage and Drainage By-laws 1981

### Preliminary and definitions

#### 1.0 Citation

These by-laws may be cited as the *Metropolitan Water Supply, Sewerage and Drainage By-laws 1981*<sup>1</sup> and shall come into operation on 1 March 1981.

#### 1.1 Interpretation

In these by-laws, unless the context otherwise requires —

“**Approved**” means approved by the Corporation or by a duly designated officer of the Corporation.

“**AS/NZS**”, followed by a designation consisting of a number and a year, means the Australian/New Zealand Standard having that designation that is published jointly by Standards Australia and Standards New Zealand and includes any amendment to that standard made before the commencement of the *Metropolitan Water Supply, Sewerage and Drainage Amendment By-laws 1998*<sup>1</sup>;

“**Backflow**”— in relation to water supply installation means the flow of water or other fluids into the water supply pipe of a

**bl. 1.1**

---

property, or a watermain, from any source or sources or in a manner other than approved.

**“Bore”, “Diameter” or “Size”**— in reference to —

- (a) any pipe of copper or brass, means the external diameter of the pipe; and
- (b) any pipe of any other material, means the internal diameter of the pipe.

**“Branch property sewer”** means any branch off a property sewer.

**“Commercial Type”** means other than domestic type.

**“Container”** means the vessel in which the heated water is stored; sometimes referred to as the storage container, cylinder or tank.

**“Cross Connection”** means any connection or arrangement, physical or otherwise, between any potable water supply system directly connected to a water main, and any fixture, storage tank, receptacle, equipment or device, through which it may be possible for any non-potable, used, unclean, polluted or contaminated water, or any other substance, to enter any part of such potable water supply system under any conditions.

**“Disconnecter Trap”** means a trap used in the separate pipe system for isolating or disconnecting waste pipes from the property sewer and soil pipes and for providing inlet ventilation to the waste pipe or pipes discharging into it.

**“Discharge Pipe”** means any pipe for the conveyance of sewage or trade waste.

**“Domestic Purposes”**, in relation to the supply of water, means the supply of water to rated land classified as residential under the *Water Agencies (Charges) By-laws 1987* or exempt land used for residential purposes; the term also includes the use of water for watering lawns and gardens appurtenant to the land and for watering lawns and gardens growing in a street or road adjoining the land and for the

purpose of these by-laws shall include water used for toilet, ablution or kitchen purposes in land rated as industrial or commercial.

**“Domestic Sewage”** means all faecal matter, urine, household slops and household liquid refuse.

**“Domestic Type”** means a fixture or appliance which is designed for use in residential situations. A fixture or appliance of this type may be installed in a non-residential building, but the sewage which it discharges shall be similar to that which would be discharged if installed in a residential situation.

**“Drainage Plumbing”** means the installation, renewal, replacement, alteration, repair or maintenance of —

- (a) below ground property sewers which operate under gravity flow conditions;
- (b) sanitary drainage pumping pits and any associated pressure mains; or
- (c) any associated manholes, branch drains, fittings or industrial waste arrestors.

**“Educt Vent”** means an opening or pipe for the exit of air from a soil pipe, waste pipe, combined waste pipe or property sewer.

**“Feeder”** means any water course, creek, stream or other channel with either perennial or intermittent flow whereby water can be conveyed to any reservoir.

**“Flat”** means a suite of rooms used or intended or adapted for use as a separate habitation and comprised in a building containing one or more similar suites.

**“Ground”** means the surface of the earth, soil, or rock which conform to the established finished grade at a specific location after all excavations have been thoroughly backfilled or otherwise closed and after all surface treatment at said location has been completed.

**bl. 1.1**

---

**“High-Water Mark”** means the level of full supply of any reservoir or feeder thereto.

**“Indirectly Connected”** means interrupted by a water seal or air gap as applicable to the situation.

**“Induct vent”** means an opening or pipe for the admission of air to a soil pipe, waste pipe, combined waster pipe or property sewer.

**“Industrial Waste”** means the liquid, solid or gaseous refuse from any business, industry, warehouse or manufacturing premises other than domestic sewage, stormwater, or unpolluted water.

**“Inspector”** means any person appointed by the Corporation for purposes connected with the administration of these by-laws, and also any person acting in the capacity of ranger of any proclaimed catchment area.

**“Licensed Plumber”** means a person who holds a plumber’s licence.

**“Observation Well”** means a well constructed for the purposes of observing the depth to the ground water from the top of the well, and for obtaining samples of the ground water.

**“Pesticides”** means a substance or compound used or intended for use for agricultural, pastoral, horticultural, domestic, or industrial purposes for controlling, destroying or preventing the growth and development of any fungus, virus, insect, mite, mollusc, nematode, plant or animal and includes all admixtures containing any proportion of any one or more of them.

**“Pipework”** is the assembly of pipes and fittings.

**“Plumber’s Licence”** means a water supply and sanitary plumber’s licence, a water supply plumber’s licence or a drainage plumber’s licence under by-law 30.4.

**“Private Service”** includes all the pipes and fittings, and all connections and apparatus of any nature or kind, whether used temporarily or otherwise, on any part of any land or

building, supplied with water, whether by meter or otherwise and includes any pipes or fittings the property of the consumer, which are used for conveying water from the mains of the Corporation whether situated on the premises of the consumer or otherwise.

**“Production Well”** means a well owned and operated by the Corporation and from which groundwater is extracted for the provision of a public water supply.

**“Residential Building”** means a building in which sleeping accommodation is provided for persons other than caretakers and their families and includes dwellings, tenements, flats, hotels, lodging houses, dormitories, hospitals and motels.

**“Sanitary Plumbing”** means the installation, renewal, replacement, alteration, repair or maintenance of above ground pipework, fittings and fixtures which convey waste to the sanitary drainage system.

**“Spill Level”** of any fixture, storage tank or receptacle is the maximum height to which water will rise while overflowing freely either over its rim or through any channels or overflows that are provided and have a free discharge to the atmosphere under all conditions, when water is flowing into such fixture, storage tank or receptacle at the maximum rate under a pressure equal to a head of 70 m applied either at the outlet end of the pipe or at the inlet to the fitting or valve actually discharging such water, with all the service outlets of such fixture, storage tank or receptacle closed.

**“The Act”** means the *Metropolitan Water Supply, Sewerage, and Drainage Act 1909*<sup>1a</sup>, as amended from time to time.

**“Trade Waste”** means liquid waste, other than domestic sewage and as defined by the Corporation. See **“Industrial Waste”**.

**“Vented”** refers to a discharge pipe with a vent connected at its upstream end.

**bl. 1.1**

---

**“Vent Pipe”** means any pipe used or intended to be used for ventilating soil pipes, waste pipes, property sewers, traps, connections or sewers.

**“Vent Stack”** means a vertical vent pipe installed primarily for the purpose of providing circulation of air to and from any part of a property sewer on the sewerage system.

**“Water Heater”** means an appliance, usually self-contained, for heating water which is either stored in it or passing through it.

**“Water Seal”** or **“Trap Seal”** means the vertical distance between the dip and the crown weir of a trap as shown in sketch.

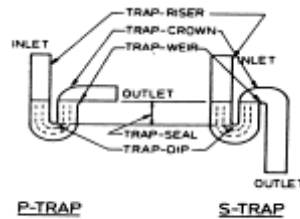

**FIGURE 1-2 TRAPS**

**“Water Service”** means the pipes and fittings used or intended to be used for the supply of water from a watermain up to and including the meter assembly and temporary building standpipe, if any, of each property.

**“Water Supply Plumbing”** means the installation, renewal, replacement, alteration, repair or maintenance of water supply systems.

**“Water Supply System”** means the pipes and fittings used or intended to be used for the supply of water from a meter assembly to the points of usage within any property, and includes any water storage tank or pipes therefrom.

**“Waste Pipe”** means a pipe which conveys the discharge from waste fixtures only.

**“Yard Gully”** means a disconnector trap which is used externally and fitted with a basin top and grating.

*[By-law 1.1 amended in Gazette 24 December 1982 pp.4924-5; 29 June 1989 p.1888; 21 September 1990 p.4952; 29 December 1995 pp.6319-20 and 6324; 4 February 1997 p.713; 25 August 1998 pp.4724-5.]*

## **1.2 Definitions in AS/NZS 3500 apply**

Subject to by-law 1.3, a word or expression that —

- (a) is used in a provision of AS/NZS 3500.2.2:1996, AS/NZS 3500.4.2:1997 or AS/NZS 3500.1.2:1998 specified in by-law 7.1 or 16.1 or in any such provision as modified by either of those by-laws; and
- (b) is given a meaning in AS/NZS 3500.0:1995,

has that meaning when so used.

*[By-law 1.2 inserted in Gazette 25 August 1998 p.4726.]*

## **1.3 Variations from definitions in AS/NZS 3500**

For the purposes of by-laws 7.1 and 16.1, a reference in a provision of AS/NZS 3500.2.2:1996, AS/NZS 3500.4.2:1997 or AS/NZS 3500.1.2:1998 specified in those by-laws to —

- (a) “authority”, “local regulatory authority”, “local statutory authority”, “regulatory authority” or “responsible regulatory authority” is to be taken, unless the context otherwise requires, to be a reference to the Corporation;
- (b) “backflow” is to be taken to be a reference to backflow as defined in by-law 1.1;
- (c) “branch drain” is to be taken to be a reference to a branch property sewer as defined in by-law 1.1;
- (d) “conduit” is to be taken to be a reference to a conduit within the meaning of the *Water Agencies (Powers) Act 1984*;

**bl. 1.4**

---

- (e) “fitting” is to be taken to be a reference to a fitting within the meaning of the *Water Agencies (Powers) Act 1984*;
- (f) “fixture” is to be taken to be a reference to a fixture within the meaning of the *Water Agencies (Powers) Act 1984*;
- (g) “ground” is to be taken to be a reference to ground as defined in by-law 1.1;
- (h) “main drain” is to be taken to be a reference to a property sewer within the meaning of the *Water Agencies (Powers) Act 1984*;
- (i) “pipe” is to be taken to be a reference to a pipe within the meaning of the *Water Agencies (Powers) Act 1984*;
- (j) “sewer” is to be taken to be a reference to a sewer within the meaning of the *Water Agencies (Powers) Act 1984*;
- (k) “spill level” is to be taken to be a reference to spill level as defined in by-law 1.1;
- (l) “trade waste” is to be taken to be a reference to industrial waste as defined in by-law 1.1;
- (m) “water heater” is to be taken to be a reference to a water heater as defined in by-law 1.1; and
- (n) “water service” or “water supply system” is to be taken to be a reference to a water supply system as defined in by-law 1.1.

*[By-law 1.3 inserted in Gazette 25 August 1998 pp.4726-7.]*

**1.4 Inconsistency of definitions**

If there is any conflict or inconsistency between a provision of AS/NZS 3500.2.2:1996, AS/NZS 3500.4.2:1997 or AS/NZS 3500.1.2:1998 specified in by-law 7.1 or 16.1 and a provision of these by-laws, the latter provision prevails.

*[By-law 1.4 inserted in Gazette 25 August 1998 p.4727.]*

*[Figure 1.3 deleted in Gazette 25 August 1998 p.4727.]*



## **2.0 Protection of the Board's works and property**

### **2.1 General**

2.1.1 By-laws in this Part are intended to —

- (a) Protect the Corporation's works and property from interference or damage that would hinder or prevent normal operation of the system.
- (b) Regulate the entry of persons onto Corporation property and behaviour of those persons while entered thereon.

*[By-law 2.1.1 amended in Gazette 29 December 1995 pp.6324 and 6326.]*

2.1.2 Attention is drawn to by-law 31.4 regarding penalties that may be imposed for breaches of these by-laws.

### **2.2 Protection of works**

2.2.1 No unauthorized person shall use waterworks and fittings which are the property of the Corporation.

*[By-law 2.2.1 amended in Gazette 29 December 1995 p.6324.]*

2.2.2 No person shall wilfully or carelessly damage or cause damage to waterworks and fittings which are the property of the Corporation.

*[By-law 2.2.2 amended in Gazette 29 December 1995 p.6324.]*

2.2.3 No person shall carry on, or cause to be carried on, any mining or quarrying operation, or make any excavation of any sort, or cause any explosion or other action in the vicinity of the Corporation's or the Commission's works which may cause damage or future damage by subsidence of the ground, without the written permission of the Corporation or the Commission as the case requires and under such conditions as the Corporation or the Commission as the case requires may deem necessary.

*[By-law 2.2.3 amended in Gazette 29 December 1995 p.6320.]*

**bl. 2.3**

---

*[2.2.4. Repealed in Gazette 24 December 1982 p.4925.]*

2.2.5 No person shall drive, take, ride or permit any vehicle, conveyance or animal to cross any exposed pipe, valve, fitting or apparatus except at crossing points approved by the Corporation or the Commission and indicated by sign-boards.

*[By-law 2.2.5 amended in Gazette 29 December 1995 p.6320.]*

2.2.6 No person shall drive, take or ride any vehicle, conveyance or animal across underground pipelines or works, where warning signs have been erected by the Corporation or the Commission except at crossing points approved by the Corporation or the Commission and indicated by sign-boards.

*[By-law 2.2.6 amended in Gazette 29 December 1995 pp.6320 and 6326.]*

**2.3 Protection of grounds**

2.3.1 No person shall wilfully or carelessly injure, damage, disfigure, displace, or remove any fence, stake, post, pillar, pipe, survey mark, peg, tablet or notice board belonging to, or installed by the Corporation or the Commission.

*[By-law 2.3.1 amended in Gazette 29 December 1995 p.6326.]*

2.3.2 No person shall wilfully or carelessly injure, deface or disfigure any notice or copy of a by-law, rule or regulation displayed upon any tablet or notice board erected by the Corporation or the Commission.

*[By-law 2.3.2 amended in Gazette 29 December 1995 p.6326.]*

2.3.3 No unauthorized person shall open any gate, slip rail, manhole, door, or other entrance into, or trespass upon any enclosure of the Corporation's or the Commission's property without the written permission of the Corporation or the Commission as the case requires.

*[By-law 2.3.3 amended in Gazette 29 December 1995 p.6320.]*

- 2.3.4 No unauthorized person shall stand, park or leave unattended any vehicle, trailer or item of mobile equipment on property, (including depots) or reserves vested in the Corporation or the Commission except in a place set aside and designated as a Visitors Car Park.

*[By-law 2.3.4 amended in Gazette 29 December 1995 p.6326.]*

- 2.3.5 Any person driving or taking vehicles onto property (including depots) or reserves vested in the Corporation or the Commission shall comply with all signs erected thereon for the regulation of traffic speed and movement.

*[By-law 2.3.5 amended in Gazette 29 December 1995 p.6326.]*

- 2.3.6 No person shall remove, pluck or damage any wildflower, shrub, bush, tree or other plant growing on any land or reserve vested in the Corporation or the Commission.

*[By-law 2.3.6 amended in Gazette 29 December 1995 p.6326.]*

- 2.3.7 No loose paper or any refuse is to be left on any portion of the grounds of any reservoir or water, sewerage or stormwater drainage works except in the receptacles provided. Where no receptacle is provided, the loose paper or other refuse is to be removed from the site.

- 2.3.8 No person shall post or distribute bills, advertisements, or other notices on any portion of any reservoir or water, sewerage or stormwater drainage works, or on any portion of the ground in the vicinity thereof without permission in writing from the Corporation or the Commission.

*[By-law 2.3.8 amended in Gazette 29 December 1995 p.6326.]*

- 2.3.9 No person is to camp on Corporation or the Commission property, or reserves vested in the Corporation or the Commission without the written permission of the Corporation or the Commission as the case requires and subject to any conditions that the Corporation or the Commission may impose.

*[By-law 2.3.9 amended in Gazette 29 December 1995 pp.6320 and 6326.]*

**Metropolitan Water Supply, Sewerage and Drainage By-laws 1981**

**2.0** Protection of the Board's works and property

**bl. 2.3**

---

- 2.3.10 All persons using picnic or recreation areas set aside for that purpose on Corporation or the Commission property or reserves vested in the Corporation or the Commission shall obey any instructions displayed on notice boards or issued verbally by the officers of the Corporation or the Commission or other authorized persons regarding behaviour in, or use of those picnic or recreation areas.

*[By-law 2.3.10 amended in Gazette 29 December 1995 pp.6320 and 6326.]*

### **3. Protection of water against pollution**

#### **3.1 General**

- 3.1.1 By-laws contained in Part 3 are intended to prevent the contamination of water stored for distribution by the Corporation.

*[By-law 3.1.1 amended in Gazette 29 December 1995 p.6324.]*

- 3.1.2 Attention is drawn to by-law 31.4 regarding penalties for breaches of these by-laws.

#### **3.2 Protection of water purity**

- 3.2.1 No person shall throw or deposit any refuse, contaminating chemical or noxious substance into —

- (a) Any reservoir, pond or tank that holds or is intended to hold water for distribution to the Corporation's consumers.
- (b) Any pipe, conduit, valve, meter, or fitting through which potable water is to be passed.
- (c) Any pit, manhole or other structure containing valves, meters, fittings or connections to potable water mains.

*[By-law 3.2.1 amended in Gazette 29 December 1995 p.6326.]*

- 3.2.2 No person shall commit a nuisance in, upon, or in the vicinity of any waterworks.

- 3.2.3 No person shall swim, bathe, or wash in any reservoir, pond, or tank containing water stored for distribution to consumers. Nor shall any person knowingly suffer any child under their control to swim, bathe, or wash in any such reservoir, pond or tank.

- 3.2.4 No boating, canoeing, fishing, or shooting is permitted in, on or over any reservoir, pond, watercourse, or channel vested in, or under the control of the Corporation without the written authority of the Corporation.

*[By-law 3.2.4 amended in Gazette 29 December 1995 p.6324.]*

**bl. 3.2**

---

- 3.2.5 No person shall permit any dog, or other animal or bird under his ownership or control to swim in or trespass on any portion of the ground within the vicinity of any reservoir, pond, tank or watercourse or sewerage or stormwater drainage works without the written permission of the Corporation.

*[By-law 3.2.5 amended in Gazette 29 December 1995 p.6324.]*

## **4. Protection of catchment areas and water reserves**

### **4.1 General**

4.1.1 The by-laws contained in this Part are intended to —

- (a) Prevent any deterioration of the quality of water collected from the Commission's catchment areas and water reserves by way of increased bacteriological or chemical contamination, increased turbidity, or increased level of nutrients necessary to the growth of undesirable aquatic flora.
- (b) Control and manage existing and future development within the catchments and water reserves that could adversely affect water quality.
- (c) Regulate the behaviour of persons entering the catchment areas.

*[By-law 4.1.1 amended in Gazette 29 December 1995 pp.6321 and 6326.]*

4.1.2 Attention is drawn to by-law 31.4 regarding penalties that may be imposed for breaches of these by-laws.

### **4.2 Application**

4.2.1 The by-laws in this Part apply to Water Reserves and Catchment Areas constituted under the Act and within which surface or sub-surface water may be collected into an open storage reservoir before distribution to consumers.

*[By-law 4.2.1 amended in Gazette 29 December 1995 p.6321.]*

4.2.2 In this Part —

4.2.2.1 All by-laws applicable to a catchment area shall apply equally to any part of a water reserve from which water can flow into an existing storage reservoir.

**bl. 4.3**

---

4.2.2.2 Prohibited Zone means that part of a catchment area which lies —

- (a) Upstream of a dam, and
- (b) Within 2 kilometres of the top water level of any reservoir in which water is or can be stored.

4.2.2.3 Public road means a road or street as defined in the Local Government Act.

**4.3 Protection of water quality**

4.3.1 No person shall throw, deposit, discharge or leave or cause, permit or suffer to be thrown, deposited, discharged or left into or upon a catchment area or water reserve any chemical, radioactive material, litter, rubbish, offal, dung, dead animal or any noisome, noxious or polluting liquid substance, matter, or thing which is likely to pollute the catchment area or water reserve or any reservoir or watercourse in the catchment area, or which is likely to affect purity of the water.

4.3.2 No person shall swim, bathe, or have any bodily contact with the water or wash any clothes or other articles in any stream, reservoir, aqueduct or other water works within a catchment area.

4.3.3 No person shall in or upon any watercourse, lake, reservoir, aqueduct or other water works in a catchment area set afloat, sail, propel or cause to be propelled any craft or vessel, without express permission in writing from the Commission and subject to any conditions that it may deem necessary.

*[By-law 4.3.3 amended in Gazette 29 December 1995 p.6325.]*

4.3.4 No person shall camp, or shoot, trap or hunt any game or catch, or attempt to catch, any fish or marron within a catchment area, without specific permission in writing from the Commission to which it may attach any conditions that it deems necessary.

*[By-law 4.3.4 amended in Gazette 29 December 1995 p.6325.]*



- 4.3.5 No person shall light a fire on Crown land in a prohibited S4.3.6 zone on a catchment area except in the fire places provided at authorized picnic sites unless with the written approval of the Commission, and any person lighting fires at other places on a catchment area shall comply fully with all requirements of the Bush Fires Act or restrictions promulgated under that Act.

*[By-law 4.3.5 amended in Gazette 29 December 1995 pp.6321 and 6325.]*

- 4.3.6 No unauthorized person shall enter Crown land within a prohibited zone on any catchment area except for the purposes of —
- (a) Travelling through the prohibited area on public roads, or
  - (b) Travelling along private roads constructed for the Commission or Forests Department<sup>2</sup> and which are open for public use, or
  - (c) Picnicking within designated picnic sites provided and serviced by the Commission.

*[By-law 4.3.6 amended in Gazette 29 December 1995 pp.6321 and 6325.]*

- 4.3.7 No picnic area or amenity to encourage picnicking or public recreation is to be established in any catchment area or water reserve without the written approval of the Commission.

*[By-law 4.3.7 amended in Gazette 29 December 1995 p.6325.]*

#### **4.4 Disposal of sewage and waste**

- 4.4.1 No person shall permit the water of any property sewer or any filthy or polluted water discharging from premises occupied by him or under his control, to run, flow, or be brought into any reservoir or watercourse in any catchment area or water reserve.

*[By-law 4.4.1 amended in Gazette 24 December 1982 p.4926.]*

**bl. 4.5**

---

4.4.2 Disposal of domestic sewage on catchment areas and water reserves.

4.4.2.1 All domestic sewage and liquid waste shall be treated and disposed of in accordance with the *Health (Treatment of Sewage and Disposal of Effluent and Liquid Waste) Regulations 1974* of the Public Health Department <sup>3</sup>.

*[By-law 4.4.2.1 amended in Gazette 26 June 1998 p.3420.]*

4.4.2.2 Prior approval in writing must be obtained from the Commission before a bacteriolytic treatment plant is installed within a prohibited zone or within 100 metres of the centre line of any watercourse.

*[By-law 4.4.2.2 amended in Gazette 29 December 1995 p.6325.]*

4.4.2.3 Any liquid waste not processed through a bacteriolytic treatment plant, or not capable of treatment in such a plant shall be stored in watertight tanks or receptacles (which shall be maintained in good condition) and periodically removed from the catchment area by a liquid waste removal contractor approved by the appropriate Local Health Authority, and by the Commission.

*[By-law 4.4.2.3 amended in Gazette 29 December 1995 p.6325.]*

4.4.3 The occupier of every house or premises shall provide and maintain in good condition a sufficient number of receptacles or boxes to contain all solid refuse, and the contents of these receptacles or boxes shall be removed from the catchment area at least once every week.

**4.5 Control of animals, livestock, etc.**

4.5.1 The owner or person in charge of any animals or birds shall not cause or permit any dog, horse, goat, cattle, sheep, pig, duck, geese or fowls or other species of livestock to enter or remain on any portion of a catchment area.

**bl. 4.5**

---

- 4.5.2 The occupier or owner of any land within a catchment area shall not raise or graze livestock without approval of the Commission.

*[By-law 4.5.2 amended in Gazette 29 December 1995 p.6325.]*

- 4.5.3 No person shall ride a horse or any other animal on any of the Commission's catchment areas (except along public roads) without the written permission of the Commission.

*[By-law 4.5.3 amended in Gazette 29 December 1995 pp.6325 and 6326.]*

- 4.5.4 Any animal or bird found straying within a catchment area may be —

- (a) Driven away or otherwise removed from such lands;
- (b) Sold;
- (c) Destroyed; or
- (d) Otherwise disposed of,

by any officer or person authorized by the Commission without incurring any liability on the part of the Commission to recompense the owner for the loss.

*[By-law 4.5.4 amended in Gazette 29 December 1995 p.6325.]*

- 4.5.5 No person shall slaughter any animal or bird in a catchment area without the permission of the Commission.

*[By-law 4.5.5 amended in Gazette 29 December 1995 pp.6325.]*

- 4.5.6 The owner of any animal or bird which dies upon any part of a catchment area or the person under whose charge the animal was at or immediately before the time of its death, shall forthwith upon knowing or being informed of the death of the animal or bird remove its body or carcass from the catchment area or bury the same so that all parts of the carcass are not less than 300 mm below the normal surface and restore the ground at least to its original level except that no animal or bird shall be

**bl. 4.6**

---

buried within a prohibited zone or within 100 metres of the centre line of any watercourse.

**4.6 Chemicals and flammable liquids**

- 4.6.1 The occupier or owner of any house, land or premises situated within a catchment area shall not store or use any animal manure or fertilizer unless written permission therefor has been given by the Commission and subject to any conditions that it may consider necessary.

*[By-law 4.6.1 amended in Gazette 29 December 1995 p.6325.]*

- 4.6.2 No person shall lay, place or use upon any part of the catchment area any poison, pesticide, insecticide, herbicide or other dangerous substances without written permission of the Commission and then they shall be applied in the manner required by the Pesticides Regulations of the Public Health Department<sup>3</sup>.

*[By-law 4.6.2 amended in Gazette 29 December 1995 p.6325.]*

- 4.6.3 All persons storing, laying, placing or using any explosive or dangerous goods on a catchment area shall comply with the requirements of the Explosives and Dangerous Goods Act administered by the Mines Department<sup>4</sup>.

- 4.6.4 No toxic, dangerous chemicals or radioactive materials are to be stored on the catchment areas without the prior approval of the Commission in writing, and may be subject to such conditions as the Commission considers necessary.

*[By-law 4.6.4 amended in Gazette 29 December 1995 p.6325.]*

- 4.6.5 Storage of Petroleum Products on Catchment Areas and Water Reserves.

- 4.6.5.1 Approval in writing from the Commission must be obtained before any licensed installation for the storage of petroleum or petroleum products is constructed.

*[By-law 4.6.5.1 amended in Gazette 29 December 1995 p.6325.]*

- 4.6.5.2 Petroleum products are to be stored and handled in accordance with the Flammable Liquids Regulations<sup>5</sup> issued by the Mines Department<sup>4</sup> and in addition shall comply with the following —
- (a) No underground tanks are to be situated within a prohibited zone or within 100 metres of the centre line of any watercourse.
  - (b) Every underground tank shall be installed in an impervious containment structure or membrane approved by the Commission that is capable of preventing any leakage from the tank.
  - (c) Any bunds or compounds on any premises licensed under the Flammable Liquids Regulations<sup>5</sup> shall be constructed with walls and floor impervious to the flow of petroleum products to the approval of the Commission.
  - (d) Any additional conditions that the Commission may deem necessary.

*[By-law 4.6.5.2 amended in Gazette 29 December 1995 pp.6321 and 6325.]*

- 4.6.5.3 Any person storing petroleum products on unlicensed premises are to take all precautions necessary to prevent spillage of petroleum products onto the ground.

#### **4.7 Protection of water from turbidity**

- 4.7.1 No person or corporation shall clear any portion of the catchment area or commence any excavation or any construction, alteration or diversion of roads without first obtaining the approval of the Commission in writing. This approval may be given subject to any conditions that the Commission deems necessary.

*[By-law 4.7.1 amended in Gazette 29 December 1995 p.6325.]*

**bl. 4.8**

---

- 4.7.2 No person shall drive a vehicle on any part of a catchment area other than a road or track which has a graded, gravelled, sealed, primed or other prepared surface without written approval of the Commission.

*[By-law 4.7.2 amended in Gazette 29 December 1995 p.6325.]*

- 4.7.3 No person or organization shall conduct a vehicle rally or race on a catchment area without first obtaining the Commission's written approval and then only under such conditions as the Commission may impose.

*[By-law 4.7.3 amended in Gazette 29 December 1995 pp.6325 and 6326.]*

**4.8 Control of development**

- 4.8.1 No person shall commence, carry out, change or expand any agricultural, industrial, commercial, quarrying or mining development in a catchment area without the approval in writing of the Commission which may impose any conditions thereon that it considers necessary.

*[By-law 4.8.1 amended in Gazette 29 December 1995 pp.6325-6.]*

- 4.8.2 No person is to establish or carry on an offensive trade as defined in the Health Act<sup>6</sup> on a catchment area or water reserve without written approval from the Commission which may impose conditions regarding the establishment and operation of that trade.

*[By-law 4.8.2 amended in Gazette 29 December 1995 pp.6325-6.]*

- 4.8.3 No person shall commence or proceed with the erection of a building or structure of any kind or any alterations or additions to a building or structure on a catchment area or water reserve without the approval in writing of the Commission and subject to any conditions that it may deem necessary.

*[By-law 4.8.3 amended in Gazette 29 December 1995 pp.6325-6.]*

- 4.8.4 The occupier or owner of premises in a catchment area shall maintain those premises at all times to the standards required by the Public Health Act<sup>6</sup> or the relevant Regulations made under that Act.

**4.9 Restoration after commission of an offence**

If any person or corporation commits an offence under Part 4, the Commission, upon discovery of that offence, may serve notice on the offending person or corporation to restore any damage, remove any cause of pollution, or dismantle any building carried out in contravention of these by-laws by a nominated date. Failure to comply with the notice by the nominated date shall constitute a continuing offence from that date under section 147 of the Act<sup>7</sup>, or in accordance with section 17 of the Metropolitan Water Supply, Sewerage, and Drainage Act.

*[By-law 4.9 amended in Gazette 29 December 1995 pp.6325-6.]*

**4.10 Control of persons and vehicles**

- 4.10.1 The Commission may erect signs at any position in the catchment areas or water reserves that it considers necessary to control the activities of persons or movement of vehicles entering onto or moving across the catchment areas or water reserves.

*[By-law 4.10.1 amended in Gazette 29 December 1995 pp.6325-6.]*

- 4.10.2 Any person driving or taking a vehicle, trailer, or item of mobile equipment onto or across a catchment area shall comply with all signs erected to control the speed, movement or parking of vehicles, trailers or mobile equipment.
- 4.10.3 Powers of a Ranger
- 4.10.3.1 Rangers and other persons authorized by the Commission are empowered to demand the name and address of any person

**bl. 4.10**

---

committing or reasonably suspected of committing an offence against the Act or these by-laws relating to catchment areas and water reserves.

*[By-law 4.10.3.1 amended in Gazette 29 December 1995 p.6321.]*

- 4.10.3.2 Any person who refuses to give, or gives a false name or address when such is requested by a Ranger or other authorized person is deemed to commit an offence under these by-laws.

*[By-law 4.10.3.2 amended in Gazette 29 December 1995 p.6321.]*



## **5.0 Protection of public water supply areas and underground water pollution control areas**

### **5.1 General**

5.1.1 The objectives of the by-laws in Part 5 are —

- (a) To define provisions governing the licensing, construction and operation of private wells.
- (b) To protect the Commission's production and observation wells from damage or pollution.
- (c) To prevent contamination of underground water in the pollution control areas.
- (d) To control development over the areas so as to prevent or inhibit contamination.

*[By-law 5.1.1 amended in Gazette 29 December 1995 p.6326.]*

5.1.2 Penalties for breaches of any by-laws in Part 5 shall be as set out in section 57B(4) of the Act.

5.1.3 The Commission may erect signs and notice boards in any pollution area or Public Water Supply Area for the exhibition of any by-law, rule, regulation or notice.

*[By-law 5.1.3 amended in Gazette 29 December 1995 pp.6325-6.]*

### **5.2 Control of private wells**

5.2.1 Licences —

5.2.1.1 Every application for a licence under section 57G shall be made in the form No. 1 in Schedule B to these by-laws.

*[By-law 5.2.1.1 amended in Gazette 31 July 1981 p.3169.]*

5.2.1.2 A person shall not give false or misleading information in his application for a licence.

**Metropolitan Water Supply, Sewerage and Drainage By-laws 1981**

**5.0** Protection of public water supply areas and underground water pollution control areas

**bl. 5.2**

---

5.2.1.3 A licence shall, subject to the terms, limitations and conditions endorsed thereon be in the form No. 2 in Schedule B to these by-laws.

*[By-law 5.2.1.3 amended in Gazette 31 July 1981 p.3169.]*

5.2.2.1 Progress Statements —

5.2.2.1 A licensee shall within 30 days of completing a well, or completing alterations to a well, for which a licence has been issued, forward to the Commission a statement in the form No. 3 in Schedule B to these by-laws.

*[By-law 5.2.2.1 amended in Gazette 31 July 1981 p.3169; 29 December 1995 pp.6325-6.]*

5.2.2.2 The provisions of subsection 5.2.2.1 of this by-law apply notwithstanding that the works relating to the well have been unsuccessful.

5.2.3 Measurement of Water Drawn from Well —

5.2.3.1 The Commission or any officer authorized by the Commission may fit a measuring device to any well to measure the quantity of water drawn from the well and to ensure the adequate performance of the measuring device, the Commission may —

- (a) Alter the piping or other means of conveying the water from the well, and
- (b) Fit screens and traps to the pump to protect the measuring device.

*[By-law 5.2.3.1 amended in Gazette 29 December 1995 pp.6325-6.]*

5.2.3.2 A person who damages or interferes with a measuring device or with any piping or channelling installed by or at the direction of the Commission in connection with the measuring device, or who fails to comply with a direction given pursuant to this by-law commits an offence.

*[By-law 5.2.3.2 amended in Gazette 29 December 1995 pp.6325-6.]*

---

**bl. 5.3**

- 5.2.3.3 The provisions of this by-law are in addition to and not in derogation of the provisions contained in by-law 6.7.
- 5.2.4 A person shall not construct or cause to be constructed or altered a well in any pollution area except in accordance with the *Health Act (Underground Water Supply) Regulations 1959* as amended from time to time.
- 5.2.5 A person shall not place any chemical or other substance that is capable of polluting underground water, down a well during the course of its construction, redevelopment, maintenance or operation without prior approval of the Commission.
- [By-law 5.2.5 amended in Gazette 29 December 1995 pp.6325-6.]*

**5.3 Protection of Board works**

- 5.3.1 A person shall not construct, alter or obstruct any watercourse, or drainage works in a manner that causes the flooding of any well or observation well.

**5.4 Protection of underground water quality**

- 5.4.1 In a pollution area the use, storage and transport of pesticides, the disposal of pesticide containers and the disposal of spilled pesticides shall be in compliance with the provisions of the Pesticides Regulations as amended from time to time.
- 5.4.2 In a pollution area a person shall not store animal manures or sewage sludges within 100 metres of a production well except with the approval of the Commission.
- [By-law 5.4.2 amended in Gazette 29 December 1995 p.6322.]*
- 5.4.3 In a pollution area a person shall not carry out the burial or disposal of animal or poultry carcasses, blood offal, or other refuse products in excess of 2 tonnes, unless prior approval has been obtained from the Commission.
- [By-law 5.4.3 amended in Gazette 29 December 1995 pp.6325-6.]*

**Metropolitan Water Supply, Sewerage and Drainage By-laws 1981**

**5.0** Protection of public water supply areas and underground water pollution control areas

**bl. 5.4**

---

- 5.4.4 In a pollution area a person shall not yard or house an animal within 30 m of a production well.
- 5.4.5 In a pollution area installation or operation of septic tanks, leach drains, soakwells and other apparatus for the disposal of domestic waste waters shall be carried out in conformity with the *Health (Treatment of Sewage and Disposal of Effluent and Liquid Waste) Regulations 1974* as amended from time to time and where the site is within 100 m of a production well a person shall obtain prior consent for the installation or operation from the Commission which may impose further conditions and restrictions as to the siting, construction or operation of the apparatus, in which event the Commission shall meet any consequential extra cost incurred in the initial construction of the apparatus.
- [By-law 5.4.5 amended in Gazette 29 December 1995 pp.6325-6; 26 June 1998 p.3420.]*
- 5.4.6 In a pollution area or a part of a pollution area a person shall not dispose of or discharge onto or into the ground, or into any lake, swamp or drain industrial wastes, chemicals, radioactive material, petroleum or petroleum products, polluted water, or refuse unless that person has been granted permission in writing by the Commission to do so.
- [By-law 5.4.6 amended in Gazette 29 December 1995 pp.6325-6.]*
- 5.4.7 A person shall not discharge into any well or observation well any chemical, industrial waste, treated or untreated sewage, effluent or other matter which in the opinion of the Commission may pollute the underground water.
- [By-law 5.4.7 amended in Gazette 29 December 1995 pp.6325-6.]*

---

**bl. 5.5**

- 5.4.8 The holder of a permit referred to in by-law 5.5.2, shall notify the Commission immediately any spillage occurs that might pollute the groundwater, either directly or indirectly, and where that spillage occurs.

*[By-law 5.4.8 amended in Gazette 24 December 1982 p.4926; 29 December 1995 pp.6325-6.]*

- 5.4.9 Any person spilling, or being aware of any leakage of, any petroleum product in a pollution area shall notify the Commission immediately of that occurrence.

*[By-law 5.4.9 amended in Gazette 29 December 1995 pp.6325-6.]*

**5.5 Control of development**

- 5.5.1 A person shall not establish an offensive trade in accordance with the provisions of the *Health Act 1911*, in a pollution area, unless they have obtained the consent of the Board to do so, and unless they comply with any conditions which the Board may impose in relation to the establishment of that offensive trade.

- 5.5.2 The establishment or operation of any premises for the storage, packaging, formulating, processing, manufacturing, sale, testing or use of chemicals or other substances liable to pollute underground water in a pollution area shall be subject to the following terms, provisions and conditions —

- (a) application shall be made to the Commission in writing for a permit to operate existing or proposed premises and the application shall set out —
  - (i) The process or processes of manufacture, packaging, storage, formulating, testing, or use of all raw materials and fuels, intermediate products and final products including waste material and effluents whether gaseous, liquid or solid.

**bl. 5.5**

---

- (ii) The quantities of raw materials, and fuels used and the intermediate and final products, waste materials, effluents, being or proposed to be produced.
  - (iii) The methods proposed to treat and dispose of any wastes, by-products and effluents, including stormwater and wash down water where this may be or could become polluted.
  - (iv) Plans and procedures proposed to prevent pollution of underground water, including emergency plans and procedures for contingencies such as accidental spillage or malfunction of any manufacturing, storage, transport or treatment process or system, both on and off the premises where this is applicable.
  - (v) Such other information required by the Commission to assess the pollution risk to underground water and to assist with measures to prevent pollution.
- (b) Upon receipt of the permit for the operation of the premises the applicant shall enter into a written agreement with the Commission to comply with the conditions of the permit which may where so required include conditions that where at any time in the opinion of the Commission —
- (i) The occupier is not fully and faithfully performing and observing the terms, provisions and conditions of the permit or any by-law;
  - (ii) The raw materials, intermediate products and final products, wastes, effluents, fuels or any other substances are not in compliance with the terms, provisions or conditions of the permit;
  - (iii) The apparatus, the subject of the permit is not in efficient working order;

---

**bl. 5.5**

- (iv) Pollution of the groundwater may be occurring or about to occur; or
- (v) Any other breach of the agreement has been made, the Commission may serve a notice in writing upon the occupier of the property, by delivering it or posting it addressed to him at the property, specifying the matter or matters in respect of which a breach has taken place, or as to which the occupier is in default, or concerning which there is any complaint by the Commission, and the notice shall require the occupier to make good the same in all things to the satisfaction of the Commission, within a period to be stated therein, from the date of service thereof in a manner so specified, and the notice shall also state that the Commission is at liberty to terminate and put an end to the permit.
- (c) The occupier shall notify the Commission in writing of his desire to make any alteration which shall in any way affect the nature and quantity of the raw materials, fuels, intermediate and final products, wastes and effluents, or the apparatus plans and procedures the subject of the permit, and which may affect the risk of pollution to underground water, and shall not make such an alteration without prior approval in writing from the Commission.
- (d) The person to whom the permit is granted shall notify the Commission in writing of any change of ownership or occupancy of the property, at least 14 days prior to the change.
- (e) The permit shall not be assigned or transferred, unless the consent of the Commission in writing has been first obtained.
- (f) The Commission may require the owner or occupier of any premises the subject of a permit from the Commission to install sample collection apparatus, measuring equipment and observation wells in the

**Metropolitan Water Supply, Sewerage and Drainage By-laws 1981**

**5.0** Protection of public water supply areas and underground water pollution control areas

**bl. 5.5**

---

ground for the purpose of measuring the depth to the ground water and for obtaining samples of ground water, or for any other purpose.

- (g) The Commission or any authorized officer, servant, agent, or workman of the Commission shall be at liberty at any time and from time to time to enter upon the property and every part thereof and to take samples or measurements and otherwise to inspect the apparatus stored or situated on the property.

*[By-law 5.5.2 amended in Gazette 29 December 1995 pp.6325-6.]*

- 5.5.3 Where the requirements of a notice referred to in by-law 5.5.2(b) have not been complied with on the expiration of the period mentioned therein, the permit shall automatically terminate, and the Commission, by its officers or authorized agents may enter upon the property, and at the expense of the occupier disconnect or stop the apparatus used and take such other action as may be deemed necessary to prevent or stop pollution of groundwater that may be occurring or which might occur, and the occupier shall not be entitled to compensation in connection therewith.

*[By-law 5.5.3 amended in Gazette 24 December 1982 p.4926; 29 December 1995 pp.6322 and 6325-6.]*

- 5.5.4 Any person handling petroleum and other flammable liquids in a pollution area shall store and handle those liquids in accordance with the *Flammable Liquids Regulations 1967*<sup>5</sup>, as amended from time to time and in addition shall comply with the following requirements —
- (a) Underground tanks for the storage of petroleum products shall not be installed within 100 m of a production well.
- (b) All underground tanks for the storage of petroleum products shall be installed in impervious containment structures or membranes approved by the Commission capable of preventing any leakage from the storage tank to the ground or ground water.



---

**bl. 5.6**

- (c) Any bunds or compounds on any premises licensed under the *Flammable Liquids Regulations 1967*<sup>5</sup>, as amended from time to time, shall be constructed so that the walls and floor of the bund or compound are of impervious material to the approval of the Commission.
- (d) Where a person intends to store flammable liquids in a pollution area, they shall apply to the Commission for its prior approval, setting out the location of proposed structures, buildings and tanks and shall abide by any conditions which the Commission may impose.

*[By-law 5.5.4 amended in Gazette 29 December 1995 pp.6322 and 6325-6.]*

- 5.5.5 A person storing or using petroleum products in a pollution area at unlicensed premises in accordance with Part III of the *Flammable Liquids Regulations 1967*<sup>5</sup>, as amended from time to time, shall take all reasonable care to prevent spillage or leakage of petroleum products onto or into the ground and may be required by the Commission to install suitable impervious catchpits, or similar containment structures approved by the Commission.

*[By-law 5.5.5 amended in Gazette 29 December 1995 pp.6322 and 6325-6.]*

**5.6 Protection of pollution areas**

*[By-law 5.6 Heading inserted in Gazette 31 December 1992 p.6418.]*

- 5.6.1 In this by-law and by-laws 5.6.2, 5.6.3, 5.6.4, 5.6.5, 5.6.6, 5.6.7 and 5.6.8 —

**“automotive business premises”** means premises associated with the repair, maintenance or servicing of motor vehicles and includes premises that are to be used as or by any of the following —

- (a) an automotive maintenance and repair shop or premises where motor vehicle parts are installed;

**Metropolitan Water Supply, Sewerage and Drainage By-laws 1981**

**5.0** Protection of public water supply areas and underground water pollution control areas

**bl. 5.6**

---

- (b) a motor vehicle detailer, a car wash establishment, a motor vehicle wrecker or a vehicle depot;
- (c) a workshop for construction, mining and earthmoving equipment; or
- (d) a wholesaler or retailer of fuels and oils;

**“bulk liquid storage tank system”** means any tank, whether or not mobile, having a capacity of or greater than 250 litres, and includes the pipework fittings and filling and dispensing apparatus associated with the tank, but does not include a tank that is part of any apparatus for the bacteriolytic treatment of sewage or that contains unpolluted water;

**“elevated storage tank system”** means a bulk liquid storage tank system in which no portion of the tank is on or below the ground;

**“establish”**, in relation to a mobile bulk liquid storage tank system, includes placing that storage tank system at a location where it will operate for a purpose other than the delivery to, or collection from, another bulk liquid storage tank system;

**“ground storage tank system”** means a bulk liquid storage tank system in which any portion of the tank is on or below the ground;

**“owner”** has the same meaning as in section 6<sup>8</sup> of the *Local Government Act 1960*;

**“plans”** means the plans showing the locations of pollution areas, priority 1, 2 and 3 source protection areas, wellheads and wellhead protection zones, copies of which are available for public inspection at the offices of the Commission, and representations of which are set out in the Schedule after by-law 5.6.8;

**“priority 1 source protection area”, “priority 2 source protection area” and “priority 3 source protection area”** mean the portions of pollution areas designated, respectively, “P1”, “P2” and “P3” on the plans;

**“tank”** includes all the tanks that are connected in, or otherwise form part of, the same bulk liquid storage tank system;

**“unpolluted water”** means water that, if released from storage, would not contaminate groundwater or other water resources;

**“wellhead”** means a well, or the location of a proposed well, identified on the plans by its name adjacent to a black circle;

**“wellhead protection zone”** means that area within a pollution area that surrounds a wellhead, the extent of which is identified on the plans.

*[By-law 5.6.1 inserted in Gazette 31 December 1992 pp.6418-19; amended in Gazette 30 July 1993 p.4165; 29 December 1995 p.6322.]*

5.6.2 Regardless of any other provision of these by-laws, a person shall not establish within a priority 1 or a priority 2 source protection area —

- (a) a ground storage tank system;
- (b) any automotive business premises; or
- (c) an elevated storage tank system inside a wellhead protection zone.

*[By-law 5.6.2 inserted in Gazette 31 December 1992 p.6419.]*

5.6.3 A person shall not establish, or increase the capacity of, an elevated storage tank system within a priority 1 or priority 2 source protection area unless —

- (a) the person has applied for a permit under by-law 5.6.4;

**Metropolitan Water Supply, Sewerage and Drainage By-laws 1981**

**5.0** Protection of public water supply areas and underground water pollution control areas

**bl. 5.6**

---

- (b) the Commission has issued a permit authorizing the establishment, or increase in capacity, of the storage tank system; and
- (c) the person complies with the terms and conditions of the permit.

*[By-law 5.6.3 inserted in Gazette 31 December 1992 p.6419; amended in Gazette 29 December 1995 p.6327.]*

**5.6.4** An application for a permit to establish, or increase the capacity of, an elevated storage tank system on land within a priority 1 or priority 2 source protection area shall be made —

- (a) in writing to the Commission; and
- (b) by the owner of the land or, if the owner is not the occupier, by the occupier of the land.

*[By-law 5.6.4 inserted in Gazette 31 December 1992 p.6419; amended in Gazette 29 December 1995 p.6327.]*

**5.6.5** The Commission may only issue a permit applied for under by-law 5.6.4 —

- (a) for an elevated storage tank system that, including any proposed increase in capacity, does not exceed 5 000 litres, unless the Commission is satisfied that there are special circumstances relevant to the issue of that permit; and
- (b) if, regardless of the present or proposed capacity of the elevated storage tank system the subject of the application, the Commission is satisfied that there is no undue risk that the purity of underground water in the source protection area in which the storage tank system is to be established, or increased in capacity, will be affected detrimentally, either directly or indirectly, by the establishment, or increase in capacity, of that storage tank system.

*[By-law 5.6.5 inserted in Gazette 31 December 1992 p.6419; amended in Gazette 29 December 1995 p.6327.]*

---

**bl. 5.6**

- 5.6.6 By-laws 5.5.2(other than paragraph (a)) and 5.5.3, as they relate to permits, apply, to the extent that they are applicable and with appropriate modifications, to a permit applied for under by-law 5.6.4.

*[By-law 5.6.6 inserted in Gazette 31 December 1992 p.6419.]*

- 5.6.7 The Commission, by notice in writing served on a person who, in contravention of by-law 5.6.2 or 5.6.3, as the case may be —

- (a) has established, or increased the capacity of, a storage tank system; or
- (b) has established any automotive business premises,

may direct that person within such period, being not less than 21 days after the service of the notice, as specified in the notice, to dismantle and remove the storage tank system or the business premises.

*[By-law 5.6.7 inserted in Gazette 31 December 1992 pp.6419-20; amended in Gazette 29 December 1995 p.6327.]*

- 5.6.8 If a person fails to comply with a notice served on that person under by-law 5.6.7 —

- (a) the person commits an offence; and
- (b) the Commission may itself dismantle and remove the storage tank system or the business premises the subject of the offence.

*[By-law 5.6.8 inserted in Gazette 31 December 1992 pp.6420-1; amended in Gazette 29 December 1995 p.6327.]*

**Metropolitan Water Supply, Sewerage and Drainage By-laws 1981**

**5.0 Protection of public water supply areas and underground water pollution control areas**

**bl. 5.6**

**SCHEDULE**

[by-law 5.6.1]

**Locations of Priority Source Protection Areas,  
Wellheads and Wellhead Protection Zones**

**Plan 1 — Mirrabooka Underground Water Pollution Control Area**



Plan 1 - Mirrabooka Underground Water Pollution Control Area

WELL NAME	WELL HEAD PROTECTION ZONE (RADIUS) (METERS)
M100	300
M105	300
M110	300
M115	300
M120	300
M125	300
M130	300
M135	300
M140	300
M145	300
M150	300
M155	300
M160	300
M165	300
M170	300
M175	300
M180	300
M185	300
M190	300
M195	300



**LOCATIONS OF PRIORITY SOURCE PROTECTION AREAS,  
WELLHEADS AND WELLHEAD PROTECTION ZONES**



Plan 2 — Gngangara Underground Water Pollution Control Area

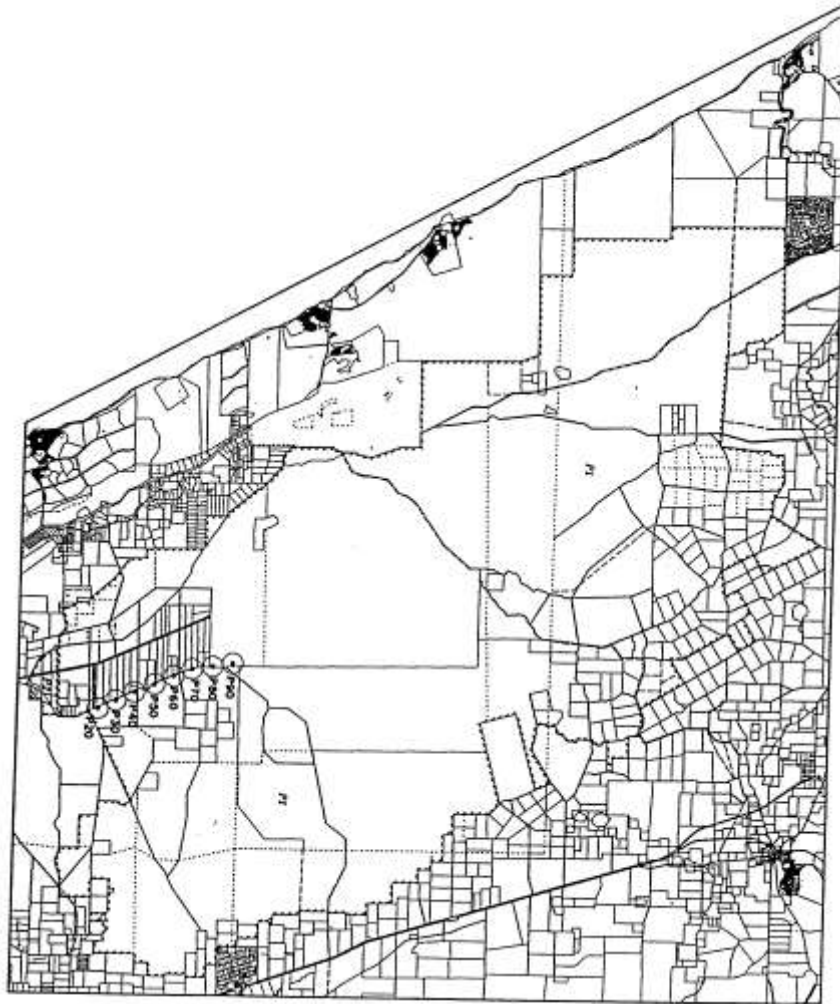

GNGANGARA UNDERGROUND WATER POLLUTION CONTROL AREA

WELLHEAD PROTECTION ZONES	
WELL NAME	WELLHEAD PROTECTION ZONE RADIUS (metres)
P30	500
P33	500
P40	500
P50	500
P45	500
P70	500
P80	500
P90	500

- LEGEND
- Priority 1 Source Protection Area
  - Priority 2 Source Protection Area
  - Well Head protection zones.
  - Wellhead



**Metropolitan Water Supply, Sewerage and Drainage By-laws 1981**

**5.0 Protection of public water supply areas and underground water pollution control areas**

**bl. 5.6**

**Plan 3 — Wanneroo Underground Water Pollution Control Area**

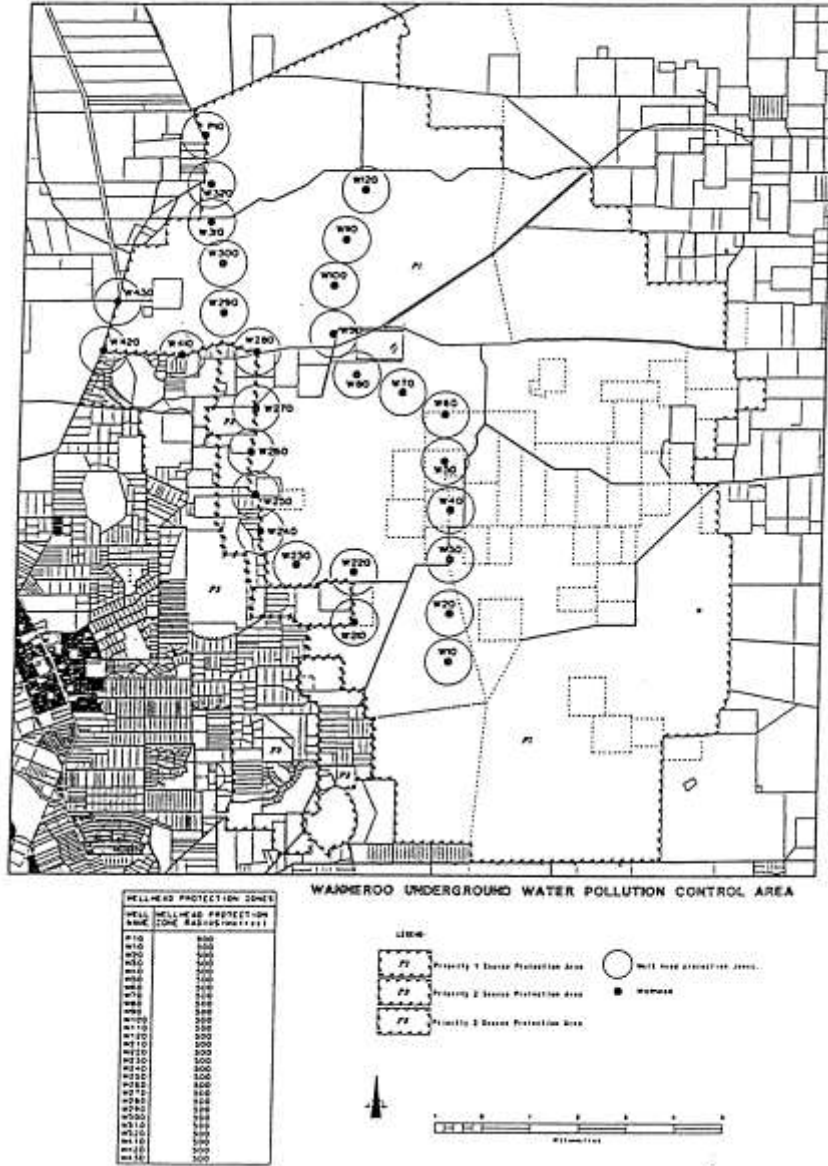



Plan 4 — Jandakot Underground Water Pollution Control Area



JANDAKOT UNDERGROUND WATER POLLUTION CONTROL AREA

WELL NO.	WELL HEAD PROTECTION ZONE RADIUS (metres)
J10	300
J11	300
J12	300
J13	300
J14	300
J15	300
J16	300
J17	300
J18	300
J19	300
J20	300
J21	300
J22	300
J23	300
J24	300
J25	300
J26	300
J27	300
J28	300
J29	300
J30	300
J31	300
J32	300
J33	300
J34	300
J35	300
J36	300
J37	300
J38	300
J39	300
J40	300
J41	300
J42	300
J43	300
J44	300
J45	300

- LEGEND:
- P1 Priority 1 Source Protection Area
  - P2 Priority 2 Source Protection Area
  - P3 Priority 3 Source Protection Area

- Well head protection zones.
- Wellhead



**Metropolitan Water Supply, Sewerage and Drainage By-laws 1981**

**5.0** Protection of public water supply areas and underground water pollution control areas

**bl. 5.6**

---

Plan 5 — Locations of Underground Water Pollution Control Areas

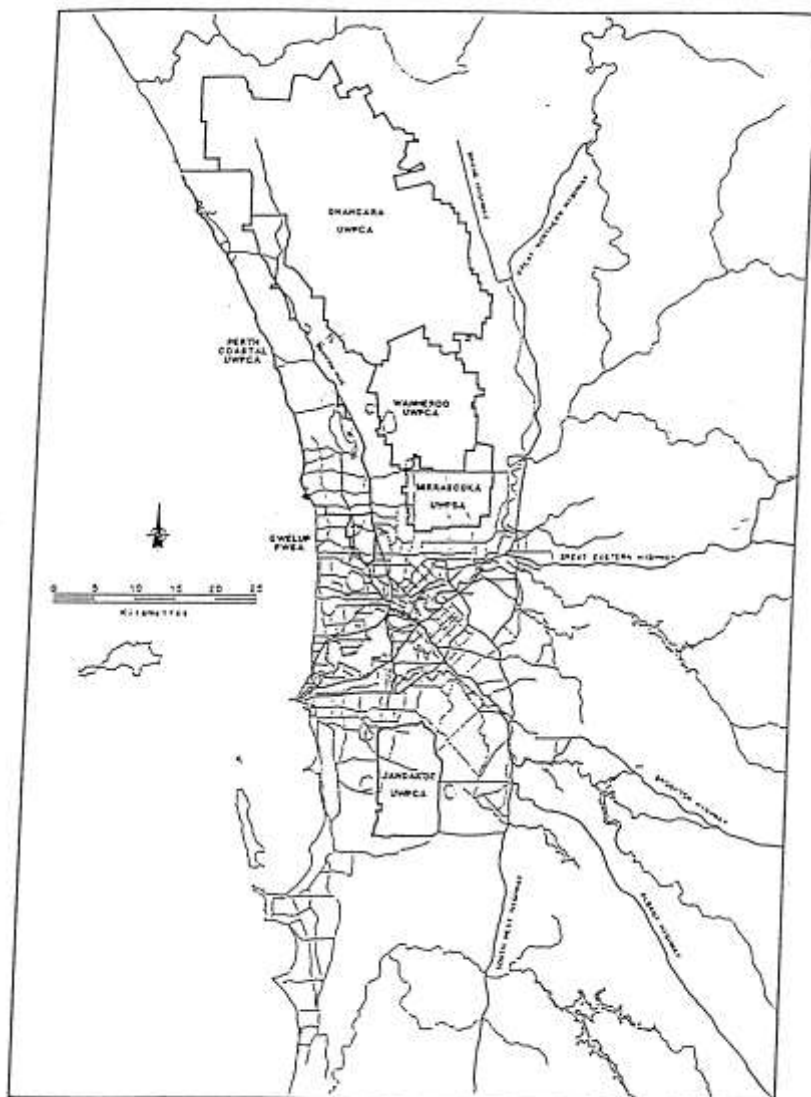

*[Schedule inserted in Gazette 30 July 1993 p.4166; amended in Gazette 23 June 1995 p.2510.]*

## **6.0 Supply of water and the installation of services and meters**

### **6.1 General**

6.1.1 By-laws contained in Part 6 are intended to define —

- (a) The purposes for which water can be used.
- (b) The conditions under which water services will be provided, altered and disconnected, and
- (c) The powers of the Corporation to install water meters on services and the consequent responsibilities of occupiers and owners.

*[By-law 6.1.1 amended in Gazette 29 December 1995 p.6324.]*

6.1.2 Attention is drawn to by-law 31.4 of the by-laws regarding penalties for offences against these by-laws.

### **6.2 Supply and use of water**

6.2.1 After receipt of an application, the Corporation may supply water for the following purposes subject to any conditions relating to the method of taking, using, and controlling the water that it may deem necessary —

- (a) Domestic purposes.
- (b) Industrial purposes.
- (c) Drinking water for stock.
- (d) Fire fighting and protection.
- (e) Cleansing, maintenance or construction of public or private roads.
- (f) Watering of public or private parks, gardens and playing fields.
- (g) Filling and operating ornamental fountains, swimming pools, wading pools, fish ponds, ornamental lakes, or any receptacle of a similar nature.

**bl. 6.2**

---

- (h) Construction of buildings or other works on private or public property.
- (i) The operation of any form of hydraulic ejector or machine.
- (j) The operation of any apparatus in which water is used for cooling including refrigerating equipment, air conditioning or any form of temperature control.

*[By-law 6.2.1 amended in Gazette 29 December 1995 p.6324.]*

- 6.2.2 Any person provided with a supply of water for a specified purpose shall not use such water for any other purpose without the written permission of the Corporation.

*[By-law 6.2.2 amended in Gazette 29 December 1995 p.6324.]*

- 6.2.3 No occupier, owner or any other person shall allow water supplied by the Corporation to run to waste or permit undue consumption. If in the opinion of the Corporation any person is wasting or unduly consuming water, it may serve notice on the occupier, owner or other person to cease the waste or undue use within a period nominated by the Corporation. Failure to prevent the waste or undue use within the nominated period shall be deemed an offence against these by-laws and the Corporation may without prejudice to any other penalty contained in these by-laws, forthwith disconnect the supply and debit the cost of the disconnection to the occupier or owner.

*[By-law 6.2.3 amended in Gazette 29 December 1995 p.6324.]*

- 6.2.4 The occupier or owner of land or premises supplied with water from the Corporation's mains shall ensure that such water is not used by persons not connected with said land or premises.

*[By-law 6.2.4 amended in Gazette 29 December 1995 p.6326.]*

- 6.2.5 No person shall, without the written permission of the Corporation, allow water supplied by the Corporation to be sold to another person, carried away, or transferred in any manner from the property or other location to which it was supplied.

*[By-law 6.2.5 amended in Gazette 29 December 1995 p.6324.]*

- 6.2.6 The Corporation may, from time to time, and without giving prior notice to the occupiers or owners affected, cut off the supply of water to any part or parts of the area for the purpose of carrying out work on its mains.

*[By-law 6.2.6 amended in Gazette 29 December 1995 p.6324.]*

*[6.2.7 Repealed in Gazette 29 September 1998 p.5405.]*

### **6.3 Services to rated properties**

- 6.3.1 The Corporation will provide one service to each rated property provided that the water is required for one of the purposes listed in by-law 6.2.1 except as set out in by-law 6.3.3.

*[By-law 6.3.1 amended in Gazette 24 December 1982 p.4926; 29 December 1995 p.6324.]*

- 6.3.2 A service will not be laid onto any rated property until the internal water supply system has been completed except as provided in by-law 6.5.2.2.

*[By-law 6.3.2 amended in Gazette 24 December 1982 p.4926.]*

- 6.3.3 Where applications are received for water services to a group of properties incorporated or to be incorporated under the Strata Titles Act <sup>9</sup> or to a group of properties under the one common ownership or use the Corporation shall provide a single water service except where the Corporation at its discretion decides that additional rated services are justified.

*[By-law 6.3.3 amended in Gazette 29 December 1995 p.6324.]*

- 6.3.4 Where an applicant requires the Corporation to provide a new water service to a rated property which has an existing disconnected service, the Corporation reserves the right to recover from such applicant the whole or part of the current cost of the disconnected service or services.

*[By-law 6.3.4 amended in Gazette 29 December 1995 p.6324.]*

**bl. 6.3**

---

- 6.3.5 The service pipe provided by the Corporation to supply water to any rated property shall not exceed 20 mm nominal internal diameter unless the Corporation at its absolute discretion decides that a pipe of greater diameter is necessary in order to maintain a reasonable supply of water to the said property.

*[By-law 6.3.5 amended in Gazette 29 December 1995 p.6324.]*

- 6.3.6 No branch or fitting shall be connected to a private service pipe within a distance of one metre on the consumer's side of the Corporation's stop-cock or water meter.

*[By-law 6.3.6 amended in Gazette 29 December 1995 p.6326.]*

- 6.3.7 No part of a private water supply system that can be fed from private water tanks or from supplies other than that provided by the Corporation shall be connected to any part of a private water supply system that is connected directly to the Corporation's service pipe. (See by-law 19.1 regarding methods of operation.)

*[By-law 6.3.7 amended in Gazette 29 December 1995 pp.6324 and 6326.]*

- 6.3.8 No occupier or owner shall connect or allow to be connected any pump to any part of a private water supply system that is supplied directly from the Corporation's service pipe without the written permission of the Corporation and without accepting in writing any conditions that the Corporation may deem necessary.

*[By-law 6.3.8 amended in Gazette 29 December 1995 pp.6324 and 6326.]*

- 6.3.9 No person shall connect or interfere, or allow any connection or interference with the Corporation's mains, service pipes or meters.

*[By-law 6.3.9 amended in Gazette 29 December 1995 p.6326.]*

- 6.3.10 Applications for water services to rated properties shall be made on the printed form procurable at the Head or Branch Offices of the Corporation, and shall be lodged not less than 7 days before the service is required.

*[By-law 6.3.10 amended in Gazette 29 December 1995 p.6324.]*

- 6.3.11 Applications for alteration of position or size, and disconnection of the Corporation's services shall be made on the printed form procurable at the Head or Branch Offices of the Corporation, and the necessary fees paid, if required, before work is commenced.

*[By-law 6.3.11 amended in Gazette 29 December 1995 pp.6324-5 and 6326.]*

- 6.3.12 The occupier or owner of any property provided with a water service from the Corporation shall ensure that the portion of the Corporation's service on his property is adequately protected from damage and shall be held liable for the cost of any repairs thereto.

*[By-law 6.3.12 amended in Gazette 29 December 1995 pp.6324-5 and 6326.]*

#### **6.4 Non-rated services**

- 6.4.1 Services covered by this by-law include —

- (a) Services to land which is exempt under by-law 4 of the *Water Agencies (Charges) By-laws 1987*.
- (b) Services to land that is not supplied with water by the Corporation and is, in the opinion of the Corporation, not reasonably capable of being so supplied.
- (c) Fire services.
- (d) Additional services.
- (e) Temporary services including hydrant services.

*[By-law 6.4.1 amended in Gazette 24 December 1982 p.4926; 29 June 1999 p.2785.]*

**bl. 6.4**

---

6.4.2 Non-rateable services may be provided at the discretion of the Corporation subject to any conditions which it may see fit to impose.

*[By-law 6.4.2 amended in Gazette 29 December 1995 pp.6324-5.]*

6.4.3 Applications for non-rateable water services shall be made on the printed form procurable at Head or Branch Offices of the Corporation, and shall be lodged, the fees paid and conditions accepted not less than 7 days before the service is required.

*[By-law 6.4.3 amended in Gazette 29 December 1995 pp.6324-5.]*

6.4.4 Applicants shall be advised in writing of any conditions to be imposed in a Letter of Conditions. In each case these conditions shall be accepted in writing, and will include provisions for the applicant to pay —

- (a) The cost of installation, maintenance where applicable, and disconnection of the service.
- (b) The cost of any main extension necessary for provision of the non-rated service.
- (c) An annual service fee and meter rental charge if applicable.
- (d) The cost of water supplied where applicable.

*[By-law 6.4.4 amended in Gazette 29 June 1999 p.2785.]*

6.4.5 By-laws 6.3.2, 6.3.3, 6.3.5 to 6.3.9 and 6.3.12 applying to rated services shall also apply to non-rated services.

*[By-law 6.4.5 amended in Gazette 24 December 1982 p.4926.]*

6.4.6 Private Fire Services —

6.4.6.1 Fire services may be provided by the Corporation for the purpose of supplying water for fire fighting and the necessary testing of firefighting equipment.

*[By-law 6.4.6.1 amended in Gazette 29 December 1995 pp.6324-5.]*



- 6.4.6.2 Subject to by-law 6.4.4 the Corporation will lay to each property or group of properties under the one common ownership or use —
- (a) A single or dual fire service for the operation of sprinklers, or
  - (b) A single fire service for the operation of hydrants or hose-reels.

*[By-law 6.4.6.2 amended in Gazette 24 December 1982 p.4926; 29 December 1995 pp.6324-5.]*

- 6.4.6.3 Seals may be affixed to hydrant valves at the discretion of the Corporation at the expense of the occupier or owner. In the event of the seals having been broken in the case of fire or by accident or otherwise, the occupier or owner shall give notice forthwith to the Corporation and pay the cost of re-sealing.

*[By-law 6.4.6.3 amended in Gazette 29 December 1995 pp.6324-5.]*

- 6.4.6.4 No water shall be taken from any fire service except for the purpose of extinguishing fires or for the necessary testing of the service. When required by the Corporation, the occupier or owner shall notify and make any necessary arrangements with the Corporation in advance of any proposed test.

*[By-law 6.4.6.4 amended in Gazette 29 December 1995 pp.6324-5.]*

- 6.4.6.5 Where any fire service has been given the Corporation shall not be liable to provide or maintain a continuous supply or pressure of water.

*[By-law 6.4.6.5 amended in Gazette 29 December 1995 pp.6324-5.]*

- 6.4.7 Where any property is provided with 2 or more water services whether rated or otherwise, interconnection of such services through the internal private water supply system is prohibited except in the cases of —

- (a) A dual fire service provided under by-law 6.4.6.2(a) where approved non-return valves shall be provided and

**bl. 6.5**

---

maintained by the occupier or owner on each service so as to prevent a back-flow of any water into the Corporation's mains.

- (b) An additional service where the Corporation may install and maintain at the expense of the occupier or owner, a non-return valve or other approved backflow prevention device on each or any service capable of being interconnected.

*[By-law 6.4.7 amended in Gazette 24 December 1982 p.4926; 29 December 1995 pp.6324-5 and 6326.]*

- 6.4.8 Where a water supply of a non-permanent nature is required for any purpose specified in by-law 6.2.1 a temporary non-rated service may be provided.

*[By-law 6.4.8 amended in Gazette 24 December 1982 p.4926.]*

**6.5 Building services**

- 6.5.1 This by-law contains by-laws applicable to the use of water for construction purposes on rated or non-rated properties or other land for the construction of new buildings, extensions or alterations to existing buildings, or for other construction works.

*[By-law 6.5.1 amended in Gazette 24 December 1982 p.4926.]*

- 6.5.2 To Unserviced Properties —

- 6.5.2.1 Applications for services shall be made on the printed form available from Head or Branch Offices of the Corporation. Before any application is accepted the applicant must —

- (a) Provide 2 copies of the building plans.

*[(b) deleted]*

- (c) In the case of a rated service application pay any charges arising from by-laws 6.3.4 or 6.3.11.

- (d) In the case of a non-rated service application accept in writing the terms and conditions of supply and pay the appropriate fees and charges prescribed in these by-laws and the *Water Agencies (Charges) By-laws 1987*.

*[By-law 6.5.2.1 amended in Gazette 24 December 1982 p.4926; 29 June 1989 p.1888; 29 December 1995 pp.6322 and 6324-5.]*

- 6.5.2.2 Unless the Corporation provides and installs a temporary building standpipe under by-law 6.5.2.2A, the builder shall engage a licensed plumber to provide and install an adequately supported stand-pipe complete with hose-tap situated not less than one metre horizontally from the proposed stop-cock position together with the connecting pipe before the Corporation will install its service pipe.

*[By-law 6.5.2.2 amended in Gazette 29 June 1989 p.1888; 29 December 1995 pp.6324-5 and 6326-7.]*

- 6.5.2.2A The Corporation may provide and install on a building or construction site a temporary building stand-pipe together with hose-tap and pipe connection on payment by the builder of the fee set out in item 6 of Schedule C.

*[By-law 6.5.2.2A inserted in Gazette 29 June 1989 p.1888; amended in Gazette 29 December 1995 pp.6326-7; 27 June 1997 p.3216.]*

- 6.5.2.3 The builder or principal contractor shall be responsible for the protection and cost of maintenance of the Corporation's service and meter (if fitted) until he notifies the Corporation of the date of practical completion of the works under construction.

*[By-law 6.5.2.3 amended in Gazette 29 December 1995 pp.6324-5 and 6326.]*

- 6.5.3 To properties already serviced —

No water is to be used for building or construction purposes from an existing water service until the conditions contained in subsection 6.5.2.1 have been complied with.

**bl. 6.6**

---

6.5.4 All hoses in use on building or construction sites shall be fitted with a selfclosing hand-operated valve at the outlet end except when the hose is connected to any apparatus for the controlled distribution of water for a specific purpose.

6.5.5 The supply to any property may be disconnected at the expense of the builder if water is used in connection with any work in addition to that shown on the plans submitted and on which the building fee was assessed.

**6.6 Water for cooling and hydraulically operated machines**

6.6.1 See by-law 15.4 for details regarding the method of applying for and the conditions applicable to a service or sub-service provided for cooling purposes or for the operation of hydraulic machines.

**6.7 Meters**

6.7.1 The Corporation may install a water meter on any service at its discretion, and shall determine the size and class of meter in each case.

*[By-law 6.7.1 amended in Gazette 29 December 1995 pp.6324-5.]*

6.7.1A Fee for installation of meter in certain cases.

6.7.1A.1 Where the Corporation installs a meter under by-law 6.7.1 on a service to —

- (a) a unit; or
- (b) a common area or facility,

in a multi-unit development, the owner of the land shall pay the fee specified in item 5(a) of Schedule C for the installation of the meter.

*[By-law 6.7.1A.1 inserted in Gazette 21 April 1989 p.1174 (erratum in Gazette 19 May 1989 p.1499); amended in Gazette 29 December 1995 pp.6326-7; 27 June 1997 p.3216.]*

6.7.1A.2 Where a meter is installed other than under by-law 6.7.1 on a service to —

- (a) a unit; or
- (b) a common area or facility,

in a multi-unit development, the owner of the land may request the Corporation to assess whether the meter is satisfactory for the purpose of measuring the flow of water through that meter.

*[By-law 6.7.1A.2 inserted in Gazette 27 June 1997 p.3216.]*

6.7.1A.3 Where the Corporation assesses a meter under by-law 6.7.1A.2 and finds that it is satisfactory for the purpose of measuring the flow of water through that meter —

- (a) the Corporation may use the meter for the measuring of the flow of water through the meter; and
- (b) the owner shall pay the fee specified in item 5(b) of Schedule C.

*[By-law 6.7.1A.3 inserted in Gazette 27 June 1997 p.3216.]*

6.7.1A.4 Where the Corporation assesses a meter under by-law 6.7.1A.2 and finds that it is not satisfactory for the purpose of measuring the flow of water through that meter —

- (a) the Corporation shall install a meter on the service under by-law 6.7.1; and
- (b) the owner shall pay the fee specified in item 5(c) of Schedule C.

*[By-law 6.7.1A.4 inserted in Gazette 27 June 1997 p.3216.]*

6.7.1A.5 In by-laws 6.7.1A.1 and 6.7.1A.2 —

**“multi-unit development”** means a development of land consisting of 2 or more units for residential or non-residential use.

*[By-law 6.7.1A.5 inserted in Gazette 27 June 1997 p.3216.]*

**bl. 6.7**

---

- 6.7.2 Where the Corporation installs a meter under by-law 6.7.1, it shall be supplied by the Corporation and shall be set —
- (a) above normal ground level inside the boundary of the land and adjacent to the reticulation main through which the water is supplied; or
  - (b) in a pit or cubicle when this is required by the Corporation under by-law 6.7.2A.

*[By-law 6.7.2 inserted in Gazette 14 October 1988 p.4173; amended in Gazette 29 December 1995 pp.6326-7.]*

**6.7.2A** Pits and cubicles

- 6.7.2A.1 The Corporation may require the owner or occupier of land to provide, at his own cost, a pit for the purpose of housing the meter and its associated valves and fittings.

*[By-law 6.7.2A.1 inserted in Gazette 14 October 1988 p.4174; amended in Gazette 29 December 1995 pp.6326-7.]*

- 6.7.2A.2 Where a building is to be constructed or altered, the Corporation may require the owner or occupier of the land on which the building is to be constructed or altered to provide, at his own cost, a cubicle attached to or forming part of the building for the purpose of housing the meter and its associated valves and fittings.

*[By-law 6.7.2A.2 inserted in Gazette 14 October 1988 p.4174; amended in Gazette 29 December 1995 pp.6326-7.]*

- 6.7.2A.3 A person required under by-law 6.7.2A.1 or 6.7.2A.2 to provide a pit or cubicle shall do so in accordance with such requirements as the Corporation may specify in writing.

*[By-law 6.7.2A.3 inserted in Gazette 14 October 1988 p.4174; amended in Gazette 29 December 1995 p.6326-7.]*

- 6.7.3 The occupier or owner of premises where a meter has been installed shall maintain a clear space not less than 300 mm

horizontally and 1 200 mm vertically from the meter and ensure easy access for the Corporation at all times.

*[By-law 6.7.3 amended in Gazette 29 December 1995 p.6322.]*

- 6.7.4 No person shall break or in any way interfere with the seal fixed on the meter through which water is supplied by the Corporation, or turn or attempt to turn any screw, bolt, or nut on or attached to such meter, or use any tool or appliance on any such meter, or introduce or attempt to introduce any body or substance into such meter, or in any way interfere with any portion of such meter, or any pipes or fittings attached thereto.

*[By-law 6.7.4 amended in Gazette 29 December 1995 pp.6324-5.]*

- 6.7.5 Any persons supplied by the Corporation through a meter shall, on finding the meter damaged, or not registering, immediately give notice of the damage or non-registration to the Head or any Branch Office of the Corporation.

*[By-law 6.7.5 amended in Gazette 29 December 1995 pp.6324-5.]*

- 6.7.6 Protection of Water Meters

- 6.7.6.1 The occupier or owner of any property supplied through a meter affixed to the Corporation's service shall take every necessary precaution to protect the Corporation's meter from damage.

*[By-law 6.7.6.1 amended in Gazette 29 December 1995 p.6326.]*

- 6.7.6.2 All repairs required to damaged meters shall be carried out by the officers of the Corporation.

*[By-law 6.7.6.2 amended in Gazette 29 December 1995 pp.6324-5.]*

**Metropolitan Water Supply, Sewerage and Drainage By-laws 1981**

**6.0** Supply of water and the installation of services and meters

**bl. 6.7**

---

6.7.6.3 The occupier or owner shall pay to the Corporation the cost of making good any damage to such meter on demand, and if not paid on demand shall be recoverable in the same manner as water rates.

*[By-law 6.7.6.3 amended in Gazette 29 December 1995 pp.6324-5.]*



## 7.0 Water supply plumbing

[Heading to by-law 7.0 inserted in Gazette 25 August 1998 p.4730.]

### 7.1 Water supply plumbing to comply with standards

A person who carries out water supply plumbing shall ensure that the plumbing is carried out in accordance with the requirements of —

- (a) the provisions of AS/NZS 3500.4.2:1997 and AS/NZS 3500.1.2:1998 specified in the first column of the Table to this by-law, subject to any modification of those provisions specified in the second column of that Table; and
- (b) by-laws 8.1.4.4, 11.2, 12.0, 13.1.4(c), 14.2.1, 14.2.2, 14.2.3, 14.4.2.3 and 15.1(a) and (f).

Penalty: \$2 000.

#### Table

<i>Provision</i>	<i>Modification</i>
<b>AS/NZS 3500.4.2:1997</b>	
Section 1	
Section 2 (clauses 2.3, 2.6, 2.8.2 and 2.8.3)	
Section 3 (clauses 3.3, 3.4.1, 3.4.5, 3.5.2, 3.5.3, 3.6, 3.7, 3.8, 3.9, 3.10, 3.11, 3.12, 3.13.1(a) and (b), 3.13.2.1(d), (e) and (f), 3.13.2.4(c), 3.14.3 and 3.16)	Clause 3.5.2 to be read as if paragraph (b) were omitted. Clause 3.5.3 to be read as if paragraph (a) were omitted. Clause 3.5.3(b) to be read as if after “Pipes shall” the following were inserted — “ be in a conduit or shall ”.

**bl. 7.1**

---

<i>Provision</i>	<i>Modification</i>
Section 4 (clauses 4.2.3, 4.3.2, 4.7, 4.8, 4.9, 4.10.1, 4.10.3, 4.12 and 4.13)	Clause 4.9 to be read as if the asterisks which appear opposite “Expansion control valve” in Table 4.1 were replaced in each case with — “ Yes ”.  Clause 4.13.1 to be read as if paragraph (c) were omitted.
Section 5 (clauses 5.2.2, 5.2.3, 5.3.8, 5.3.10, 5.7.2.1, 5.8 and 5.9)	Clause 5.2.3 to be read as if “4.3” were replaced with — “ 4.3.2 ”.  Clause 5.3.10(d) to be read as if “6.3” were replaced with — “ 6.3.1 ”.  Clause 5.8.2 to be read as if — (a) “5.3 and 5.4” were replaced with — “ 5.3.8 and 5.3.10 ”; and (b) “Section 3.” were replaced with — “ the provisions of Section 3 specified in the Table to by-law 7.1 of the <i>Metropolitan Water Supply, Sewerage and Drainage By-laws 1981</i> as modified in that Table. ”.  Clause 5.8.3.1 to be read as if “5.3 and 5.4” were replaced with — “ 5.3.8 and 5.3.10 ”.

<i>Provision</i>	<i>Modification</i>
	Clause 5.8.4 to be read as if the passage beginning “In such cases,” and ending “permanent preheater.” were omitted.
	Clause 5.9.1 to be read as if after “Clause 4.10” the following were inserted — “ specified in the Table to by-law 7.1 of the <i>Metropolitan Water Supply,     Sewerage and Drainage     By-laws 1981</i> ”.
Section 6 (clause 6.3.1) <b>AS/NZS 3500.1.2:1998</b>	
Section 1 (clause 1.5)	
Section 2 (clauses 2.1 to 2.7 and 2.8.2)	Clause 2.4 to be read as if clause 2.4.7 were omitted.
Section 4	Clause 4.2.3 to be read as if “authorized by the regulatory authority” were omitted.  Clause 4.5 to be read as if “and be subject to the approval of the regulatory authority” were omitted.
Section 5 (clauses 5.4, 5.5.1, 5.5.2.2, 5.5.2.3, 5.6, 5.7.1, 5.9, 5.10, 5.11, 5.14, 5.16, 5.17.2, 5.18 and 5.19)	Clause 5.5.1 to be read as if paragraph (a) were omitted.  Clause 5.5.2.2 to be read as if paragraph (b) were omitted.  Clause 5.5.2.3 to be read as if paragraph (a) were omitted.

**bl. 7.1**

---

<i>Provision</i>	<i>Modification</i>
	Clause 5.5.2.3(b) to be read as if after “pipework” the following were inserted — “ , or shall be in a conduit ”.
Section 6 (clauses 6.3, 6.4 and 6.8.2)	Clause 6.4 to be read as if “Section 5.” were replaced with — “ the provisions of Section 5 specified in the Table to by-law 7.1 of the <i>Metropolitan Water Supply, Sewerage and Drainage By-laws 1981</i> as modified in that Table. ”.
Section 7	Clause 7.2(b) to be read as if after “finished ground level” the following were inserted — “ , subject to, or likely to be subject to, flooding or ponding ”.
	Clause 7.2(c) to be read as if after “finished ground level” the following were inserted — “ , subject to, or likely to be subject to, flooding or ponding ”.
Section 8 (clauses 8.2.2, 8.3.2, 8.5.5, 8.7.2 and 8.9)	

<i>Provision</i>	<i>Modification</i>
Section 9 (clauses 9.2, 9.3, 9.4.1, 9.4.2, 9.4.4, 9.6, 9.7, 9.8 and 9.9)	Clause 9.6.1 to be read as if “Section 8” were replaced with — “ the provisions of Section 8 specified in the Table to by-law 7.1 of the <i>Metropolitan Water Supply, Sewerage and Drainage By-laws 1981</i> ” Clause 9.9 to be read as if clause 9.9.5 were omitted.
Section 11 (clause 11.3)	
Section 12	
	<i>[By-law 7.1 inserted in Gazette 25 August 1998 pp.4727-30.]</i>

**7.2 Manufacturer’s specifications not to be exceeded**

A person who carries out water supply plumbing shall ensure that the maximum working pressure of pipes and other fittings, as specified by the manufacturer, is not exceeded.

Penalty: \$1 000.

*[By-law 7.2 inserted in Gazette 25 August 1998 p.4730.]*

**7.3 Installation of concealed pipes**

A person who carries out water supply plumbing that involves the installation of pipes in a concealed location shall ensure that the pipes —

- (a) are approved by the manufacturer for use in such a location; and

**Metropolitan Water Supply, Sewerage and Drainage By-laws 1981**

**7.0** Water supply plumbing

**bl. 7.3**

---

(b) are installed in accordance with the manufacturer's instructions.

Penalty: \$1 000.

*[By-law 7.3 inserted in Gazette 25 August 1998 p.4730.]*

## **8.0 Water supply plumbing materials**

*[8.1—8.1.3.3. Repealed in Gazette 25 August 1998 p.4730.]*

### 8.1.4 Special Installation Requirements

*[8.1.4.1—8.1.4.3. Repealed in Gazette 25 August 1998 p.4730.]*

#### 8.1.4.4 Testing

- (a) All unmetered fire services of asbestos cement shall be tested to 200 m pressure head without leakage.
- (b) Metered fire services of asbestos cement shall be tested to 200 m pressure head without leakage when required by the Corporation.

*[By-law 8.1.4.4 amended in Gazette 29 December 1995 pp.6324-5.]*

*[8.2—8.9. Repealed in Gazette 25 August 1998 p.4730.]*

*[9.0 (9.1—9.12). Repealed in Gazette 25 August 1998 p.4730.]*

*[10.0 (10.1, 10.2). Repealed in Gazette 25 August 1998 p.4730.]*

*[10.3—10.11. Repealed in Gazette 4 May 1993 p.2329.]*

## **11.0 Storage tanks for cold water**

### **11.1 Definition**

A storage tank is any vessel used or intended to be used for the storage of water whether under pressure or not, and not being a hot water system, or flushing cistern in accordance with AS 1218.

### **11.2 Storage tanks required**

Where required by the Corporation, water shall be supplied from storage tanks.

*[By-law 11.2 amended in Gazette 29 December 1995 p.6322.]*

#### **11.2.1 Multi-Storey Buildings**

Except where the Corporation has approved the use of a booster pump to maintain a direct supply of water to the upper storeys of a building, every water outlet installed at a height of 15 m or more above ground level, or such other height as the Corporation may specify, shall be supplied from a storage tank.

*[By-law 11.2.1 amended in Gazette 29 December 1995 pp.6324-5.]*



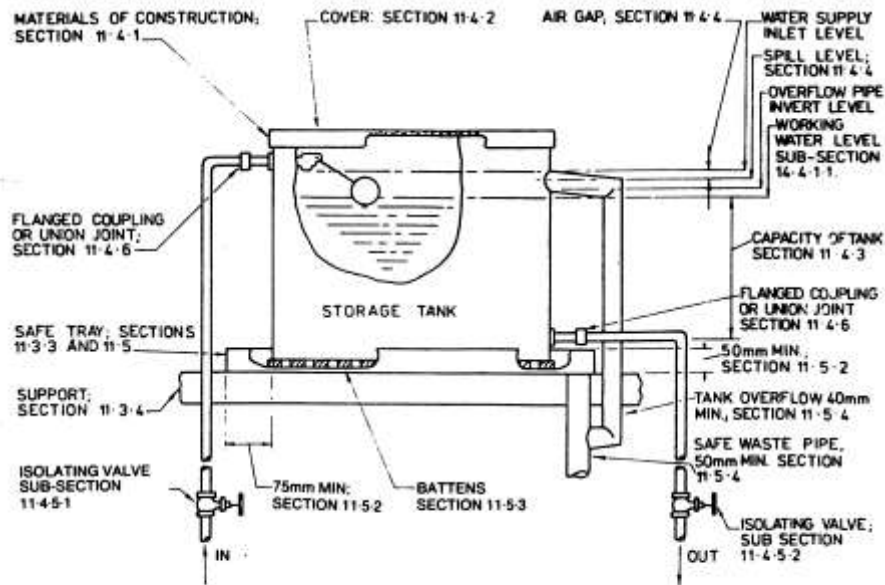

FIGURE 11-1 COLD WATER STORAGE TANK

[11.2.2, 11.2.3 Repealed in Gazette 25 August 1998 p.4730.]

[11.3—11.5. Repealed in Gazette 25 August 1998 p.4730.]

## **12.0 Joint water supply system**

### **12.1 Definition “joint water supply system”**

12.1.1 A “**joint water service**” is any privately owned water supply pipe which services 2 or more dwelling units.

12.1.2 Each dwelling or common facility shall be serviced by a separate branch from a joint water service.

### **12.2 Joint water supply system isolating valve**

An isolating valve shall be installed in all joint water supply systems in an accessible position close to the property alignment, and such that all branch connections to the joint system can be isolated from the watermain.

### **12.3 Dwelling unit isolating valve**

An isolating valve shall be installed in each separate dwelling unit service branch from the joint system in an accessible position and such that the dwelling unit supply can be isolated without affecting the water supply to other dwelling units or to common facilities.

### **12.4 Common facilities isolating valve**

An isolating valve shall be installed in each water supply branch from the joint service which services common garden areas or common laundry facilities etc., such that the common facilities supply can be isolated without affecting the water supply to the separate dwelling units.

### **12.5 Provision for metering**

Where required by the Corporation provision shall be made for the installation of meters on the branch supply lines to individual dwelling units and common facilities.

*[By-law 12.5 amended in Gazette 29 December 1995 pp.6324-5.]*

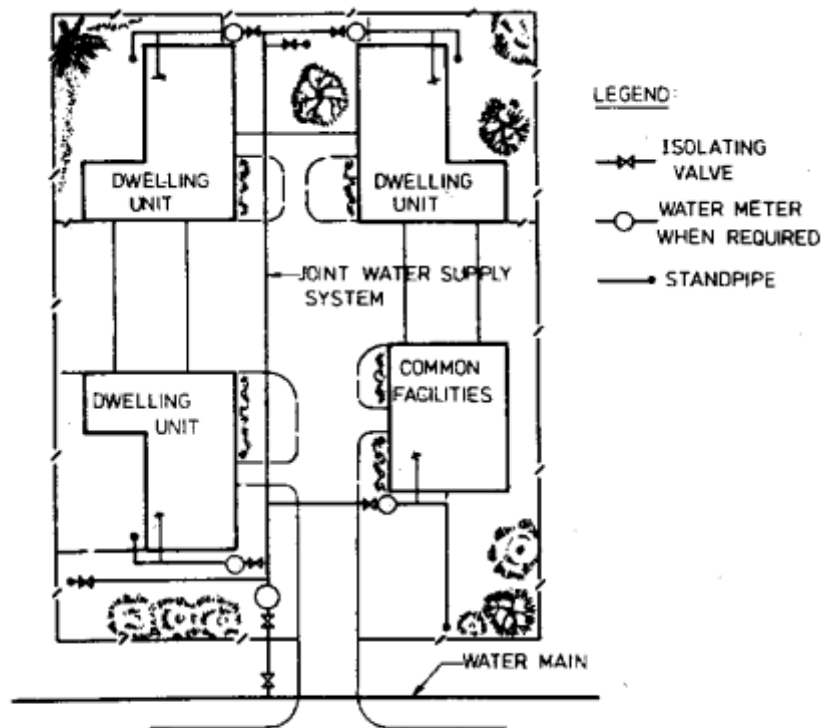

FIGURE 12.1 JOINT WATER SUPPLY SYSTEM

**bl. 13.1**

---

## **13.0 Fire services**

### **13.1 Fire hose reel installations**

*[13.1—13.1.3. Repealed in Gazette 25 August 1998 p.4731.]*

#### **13.1.4 Fire Hose Connection Points**

*[(a) and (b) repealed]*

- (c) All fire hose reels shall be connected to a metered supply unless otherwise approved.

*[By-law 13.1.4 amended in Gazette 25 August 1998 p.4731.]*

*[13.1.5, 13.1.6. Repealed in Gazette 25 August 1998 p.4731.]*

*[13.2. Repealed in Gazette 25 August 1998 p.4731.]*

## **14.0 Domestic hot water systems**

*[14.1. Repealed in Gazette 25 August 1998 p.4731.]*

### **14.2 Installation of heater**

#### **14.2.1 General**

Water heaters or hot water containers shall be installed in such a manner that the maximum rated working pressure is not exceeded.

#### **14.2.2 Accessibility of Markings**

The water heater shall be so placed that markings and instructions are readily visible.

#### **14.2.3 Access for Maintenance**

- (a) The water heater shall be placed in such a position as to give unobstructed access to all water service and pressure temperature relief fittings and controls.
- (b) Where the cylinder for a solar water heater of the mains pressure or reduced pressure type is located in an elevated position, the easing gear of the temperature pressure relief valve or temperature relief valve shall be fitted with an approved resistant mechanism which enables the easing gear to be operated from ground level.

*[14.2.4. Repealed in Gazette 25 August 1998 p.4731.]*

*[14.3. Repealed in Gazette 25 August 1998 p.4731.]*

### **14.4 Cold water supply**

*[14.4.1 and 14.4.1.1. Repealed in Gazette 25 August 1998 p.4731.]*

#### **14.4.2 Cold Water Pipework**

*[14.4.2.1 and 14.4.2.2. Repealed in Gazette 25 August 1998 p.4731.]*

**bl. 14.4**

---

14.4.2.3 All water heaters other than mains pressure water heaters shall be supplied:

- (a) from an integral cold water feed tank,
- (b) through a pressure-reducing, pressure-ratio or pressure-limiting valve,
- (c) directly from the cold water mains in the case of a free outlet water heater, or
- (d) from a cold water storage tank.

*[14.4.2.4—14.6. Repealed in Gazette 25 August 1998 p.4731.]*

## **15.0 Private water supply systems**

### **15.1 Pipes and apparatus for private services**

In connection with the laying down, maintenance, alteration, or repair of every private service, the following conditions shall be observed by the owner or occupier of the premises: —

*[(a) to (e) deleted]*

- (f) No pipe or other apparatus shall be laid through any sewer, property sewer, ash pit, cistern or manure bin, or through, in, or into, any place where in the event of the pipe becoming unsound the water conveyed through the pipe or apparatus would be liable to be polluted or to escape without observation, unless the pipe or apparatus is laid through a sleeve which may consist of an approved iron pipe or box of sufficient length and strength to afford due protection to the pipe or apparatus, and to bring any leakage or waste to notice and easy detection.

*[By-law 15.1 amended in Gazette 24 December 1982 p.4926; 29 December 1995 pp.6322, 6324-5 and 6326; 25 August 1998 p.4731.]*

### **15.2 Separate services required**

Not more than one house or tenement shall be supplied from one service except as set out in by-law 6.3.3 or with the written permission of the Corporation in special cases. When more than one house or tenement is supplied from a single service, the subservices shall be so arranged that the supply to each house shall be independent of the supply to the remaining houses and controlled by a stop-cock on such sub-services. Refer Figure 12.1.

*[By-law 15.2 amended in Gazette 29 December 1995 pp.6324-5.]*

**bl. 15.3**

---

**15.3 Notice of intention to build**

The owner or occupier of any land supplied with water who shall erect, or make, or cause to be erected or made any building or addition to an existing building on such land, shall, before the commencement of same, give notice in writing thereof to the Corporation.

*[By-law 15.3 amended in Gazette 29 December 1995 pp.6324-5.]*

**15.4 Water for cooling purposes**

15.4.1 Any apparatus in which water is used for cooling purposes, including refrigerating equipment or machinery, or any apparatus or system used for the cooling of roofs, or for any form of air conditioning or temperature control or in connection with any form of hydraulic ejector or hydraulic apparatus for power purposes, shall be deemed to be an apparatus within the meaning of this by-law.

15.4.2 The use of water for any such apparatus shall be subject to the conditions set out in this by-law.

15.4.3 From and after the commencement of this by-law, no apparatus shall be installed or used, and no apparatus previously installed shall be used in, on, or in connection with any property, land, or tenement unless the Corporation shall have first consented thereto in writing.

*[By-law 15.4.3 amended in Gazette 29 December 1995 pp.6324-5.]*

15.4.4 Applications for consent to install or use such apparatus shall be made on the printed form available at Head and Branch offices of the Corporation and shall state the make and type, the minimum and maximum requirements, and any other information the Corporation may require.

*[By-law 15.4.4 amended in Gazette 29 December 1995 pp.6324-5.]*



- 15.4.5 If water used for or in the operation of any apparatus under full output exceeds 2.27 litres per minute, it shall be reused, unless consent to run it to waste shall have been obtained in writing from the Corporation. If installation is such that the unit cuts in and out, the supply of water for cooling purposes must be automatically shut off when the unit cuts out.

*[By-law 15.4.5 amended in Gazette 29 December 1995 pp.6324-5.]*

- 15.4.6 The quantity of water run to waste shall be limited to the quantity specified in the Corporation's consent. The water which shall so run to waste shall be recorded by a meter specially affixed for the purpose and shall not exceed 16.2 litres per min. per 1 000 kilowatts of refrigeration capacity.

*[By-law 15.4.6 amended in Gazette 29 December 1995 p.6326.]*

- 15.4.7 Should water in excess of the quantity specified in the Corporation's consent be run to waste, every owner or occupier of the property, land, or tenement or other persons supplied by the Corporation who so permit or allow such excess water to be run to waste, shall be guilty of an offence.

*[By-law 15.4.7 amended in Gazette 29 December 1995 pp.6324-5 and 6326.]*

- 15.4.8 A person supplied by the Corporation with water shall, at his own expense:
- (a) make any alteration to the existing water service necessary in order that the subservice can be separately metered;
  - (b) pay the cost of removing the meter and disconnecting the subservice, if not further required; and
  - (c) during the continuance of the service, keep or cause to be kept, such apparatus, and all pipes in connection therewith, in a proper state of repair.

*[By-law 15.4.8 amended in Gazette 29 December 1995 pp.6324-5.]*

**bl. 15.8**

---

15.4.9.1 Where a person supplied by the Corporation with water desires to draw the supply direct from the Corporation's main through an additional service, such additional service shall, at the discretion of the Corporation, be installed upon such occupier or owner depositing in advance:

- (a) the amount of the estimated cost of installation; and
- (b) the amount of the estimated cost of affixing a meter.

*[By-law 15.4.9.1 amended in Gazette 29 December 1995 pp.6324-5 and 6326.]*

15.4.9.2 The owner or occupier shall, on completion of the work pay the actual costs thereof, whether they amount to more or less than the estimates. He shall also pay meter rent and bear the expense of maintaining the additional service and of having it disconnected when no longer required.

15.4.10 An owner, occupier, or other person who is supplied with water by the Corporation aforesaid, who shall fail to comply with this by-law, shall be deemed to be guilty of an offence hereunder, and shall be liable for each offence to a penalty not exceeding \$80 and to a further penalty not exceeding \$8 for each day the offence continues after notice thereof from the Corporation.

*[By-law 15.4.10 amended in Gazette 29 December 1995 pp.6324-5.]*

*[15.5. Repealed in Gazette 25 August 1998 p.4731.]*

*[15.6, 15.7. Repealed in Gazette 28 June 1985 p.2349.]*

**15.8 Maintenance of private services and interference with meters etc.**

- (a) The owner of a property supplied with water shall at his own risk and expense lay down his private service and keep it in good order and repair, in accordance with the provisions of these by-laws.

- (b)
  - (i) Upon receiving notice from the Corporation that service pipes or apparatus, which service, and are within the boundary of land, require repair, the owner of the land shall forthwith employ a licensed plumber to effect the necessary repairs.
  - (ii) An owner of land who fails to comply with subparagraph (i) shall have committed an offence and be liable to a penalty not exceeding \$200 and a further penalty of \$20 for each day on which the offence continues.
  - (iii) Until the necessary repairs have been effected, the Corporation may stop the supply of water to the land.
  - (iv) The owner of the land shall be deemed to be responsible for loss of water or damage caused by the service pipes or apparatus being out of repair.
- (c) In addition to any penalty provided by this by-law, the Corporation may cut off the supply of water to land whereon the private service is not at all times laid, fixed, used and maintained in accordance with the provisions of the said by-law, and may keep the same cut off until such provisions have been fully observed.
- (d) A branch shall not be taken off the service pipe within a distance of one metre on the consumer's side of the Corporation's stop-cock or meter.

*[By-law 15.8 amended in Gazette 24 December 1982 p.4926; 29 December 1995 pp.6324-5 and 6326.]*

### **15.9 Ornamental fountains and swimming pools**

- (a) Persons shall not connect a supply pipe to an ornamental fountain or swimming or bathing pool, wading pool, fish pond, or ornamental lake or receptacle of a similar nature, without first obtaining the written permission of the Corporation.

**bl. 15.9**

---

- (b) Where the Corporation grants permission under sub-by-law (a) of this by-law, it may specify —
- (i) The size and location of the supply pipe or pipes required;
  - (ii) whether the supply pipe shall be separate from the ordinary supply pipe;
  - (iii) the rate at which the water will be supplied;
  - (iv) the hours during which the supply of water will be permitted; and
  - (v) whether anemometer controls are to be fitted to the fountain,

and may require such supplies to be metered and recirculated.

*[By-law 15.9 amended in Gazette 29 December 1995  
pp.6324-5.]*

---

## **16.0 Sanitary and drainage plumbing**

*[Heading to by-law 16.0 inserted in Gazette 25 August 1998 p.4731.]*

### **16.1 Sanitary and drainage plumbing to comply with standard**

A person who carries out sanitary plumbing or drainage plumbing shall ensure that the plumbing is carried out in accordance with the requirements of —

- (a) the provisions of AS/NZS 3500.2.2:1996 specified in the first column of the Table to this by-law, subject to any modification of those provisions specified in the second column of that Table; and
- (b) by-laws 18.2, 18.3, 18.20, 18.23.2, 19.3, 25.7 and 26.4.8.

Penalty: \$2 000.

#### **Table**

<i>Provision</i>	<i>Modification</i>
<b>AS/NZS 3500.2.2:1996</b>	
Section 1 (clause 1.4)	
Section 3 (other than clauses 3.6, 3.15.4 and 3.17)	Clause 3.14 to be read as if paragraph (a) were omitted. Clause 3.14(b) to be read as if “other authorized materials” were replaced with — “ authorized materials (including mortar jointed vitrified clay pipes) ”.

**bl. 16.1**

---

***Provision***

***Modification***

Clause 3.15 to be read as if clause 3.15.1 were omitted.

Clause 3.15.2 to be read as if —

- (a) the passage beginning “At least one” and ending “normally contain chemicals.” were omitted; and
- (b) “The dump point” were replaced with —

“  
Where soil waste dump points are provided for a caravan park, they  
”.

Clause 3.15.3 to be read as if “sullage connection points”, were replaced with —

“ sullage dump points ”.

Section 4

Clause 4.4.3.1 to be read as if paragraph (d) were omitted.

Clause 4.6.2 to be read as if paragraph (b) were omitted.

Clause 4.6.2(d) to be read as if after “surcharge” the following were inserted —

“  
, and for external locations the grating shall be of a loose, lightweight domed, pop-out type  
”.

***Provision***

***Modification***

Table 4.3 to be read as if —

(a) in the first column “Floor waste gully or shower” were replaced with —  
“  
Floor waste gully or shower (not fitted with a hob)  
”;

(b) in the first column below “Floor waste gully or shower (not fitted with a hob)” the following were inserted —  
“ Shower (fitted with a hob) ”;  
and

(c) in the second column below “Top surface level of the grate” the following were inserted —  
“ Overflow level of the hob ”.

Clause 4.7.3(b) to be read as if after “Clause 4.8” the following were inserted —

“  
(other than clauses 4.8.4.3 and 4.8.4.7)  
”.

Clause 4.10 to be read as if paragraph (a) were omitted.

Section 5

Section 6

Section 7

Section 8

**bl. 16.2**

---

<i>Provision</i>	<i>Modification</i>
Section 9 (other than clauses 9.2, 9.6, 9.9 and 9.10)	Clause 9.3 to be read as if paragraphs (a), (b), (d), (e) and (g) were omitted.  Clause 9.4 to be read as if clauses 9.4.3, 9.4.4 and 9.4.5 were omitted.
Section 10 (other than clauses 10.9 and 10.11)	
Section 11 (other than clauses 11.2, 11.7, 11.14, 11.16, 11.21, 11.27)	Clause 11.18 to be read as if clauses 11.18.2 and 11.18.3 were omitted.  Clause 11.20 to be read as if clause 11.20.1 were omitted.  Clause 11.23 to be read as if “The” were replaced with — “ Where required by the Corporation, the ”  Clause 11.26.2.1 to be read as if paragraph (c) were omitted.  Clause 11.26.3 to be read as if after “DN 50” the following were inserted — “ and shall not discharge through a grease arrestor ”

*[By-law 16.1 inserted in Gazette 25 August 1998 pp.4731-3.]*

**16.2 Manufacturer’s specifications not to be exceeded**

A person who carries out sanitary plumbing or drainage plumbing shall ensure that the design operating conditions of



pipes and other fittings, as specified by the manufacturer, are not exceeded.

Penalty: \$1 000.

*[By-law 16.2 inserted in Gazette 25 August 1998 p.4734.]*

*[17.0, 17.1, 17.2.2. Repealed in Gazette 25 August 1998 p.4734.]*

*[17.2.3. Repealed in Gazette 22 December 1989 p.4630.]*

*[17.2.4—17.2.10. Repealed in Gazette 25 August 1998 p.4734.]*

*[17.3. Repealed in Gazette 22 December 1989 p.4631.]*

*[17.4. Repealed in Gazette 25 August 1998 p.4734.]*

**bl. 18.2**

---

## **18.0 Connection of fixtures and fittings**

*[18.1—18.1.4. Repealed in Gazette 25 August 1998 p.4734.]*

*[18.1.5. Repealed in Gazette 28 June 1985 p.2349.]*

### **18.2 Air-conditioners and plant-rooms**

- (a) Where air-conditioning plant waste is to be discharged to the sewer, the air-conditioning plant shall discharge in accordance with the requirements for instrument sterilizers and autoclaves in clause 11.21 of AS/NZS 3500.2.2:1996.
- (b) Where air-conditioning plant room waste is to be discharged to the sewer the room shall be connected either:
  - (i) through an outlet-pipe of not less than 50 mm terminating with a flap-valve over a suitably located floor-waste gully outside the room, or,
  - (ii) through an approved deep-water-seal floor-waste gully located within the room. The depth of the deep-water-seal shall be at least 75 mm plus the water gauge equivalent of the maximum pressure differential of the air-conditioning room.

*[By-law 18.2 amended in Gazette 25 August 1998 p.4734.]*

### **18.3 Arrestors**

Arrestors shall be designed, constructed and installed in accordance with the requirements of the Corporation.

*[By-law 18.3 amended in Gazette 29 December 1995 pp.6324-5.]*

*[18.4—18.6.1.1. Repealed in Gazette 25 August 1998 p.4734.]*

*[18.6.1.2. Repealed in Gazette 28 June 1985 p.2349.]*

*[18.6.2—18.7.1. Repealed in Gazette 25 August 1998 p.4734.]*

*[18.7.2. Repealed in Gazette 28 June 1985 p.2349.]*

*[18.7.3—18.16.2. Repealed in Gazette 25 August 1998 p.4734.]*

*[18.16.3, 18.16.4. Repealed in Gazette 28 June 1985 p.2350.]*

*[18.16.5—18.19. Repealed in Gazette 25 August 1998 p.4734.]*

### **18.20 Swimming pools**

*[18.20.1. Repealed in Gazette 28 June 1985 p.2350.]*

#### **18.20.2 Commercial Type Swimming Pools**

The backwash and pool drainage from commercial swimming pools constitute an industrial waste discharge and shall be connected in accordance with the industrial waste requirements of the Corporation.

*[By-law 18.20.2 amended in Gazette 29 December 1995 pp.6324-5.]*

*[18.21—18.21.2. Repealed in Gazette 25 August 1998 p.4734.]*

*[18.21.3. Repealed in Gazette 28 June 1985 p.2350.]*

*[18.22, 18.22.1. Repealed in Gazette 25 August 1998 p.4734.]*

*[18.22.2. Repealed in Gazette 28 June 1985 p.2350.]*

*[18.22.3—18.22.5. Repealed in Gazette 25 August 1998 p.4734.]*

### **18.23 Washing machines**

*[18.23.1. Repealed in Gazette 25 August 1998 p.4734.]*

**bl. 18.23**

---

18.23.2 Commercial Type Laundries

Commercial type laundry installations shall not be made until plans and specifications of the proposed work have been approved by the Corporation.

*[By-law 18.23.2 amended in Gazette 29 December 1995 pp.6324-5.]*

*[18.23.3. Repealed in Gazette 25 August 1998 p.4734.]*

*[18.23.3.1. Repealed in Gazette 28 June 1985 p.2351.]*

*[18.23.3.2—18.25.3. Repealed in Gazette 25 August 1998 p.4734.]*

## **19.0 Water supply to sanitary fixtures**

*[19.1, 19.2. Repealed in Gazette 25 August 1998 p.4734.]*

### **19.3 Flushing systems**

#### **19.3.1 General**

- (a) Subject to by-laws 19.3.2 and 19.3.3, water-closet pans, slop hoppers, urinals and such other fixtures as specified by the Corporation shall be supplied with an approved flushing system.
- (b) Flushing systems shall be so controlled, fitted and placed so as to supply water for flushing purposes without any direct connection between the flushed fixture and the water supply pipework.
- (c) Automatic flushing systems shall be approved for their application by the Corporation.
- (d) Flush pipes shall be of copper, copper alloy, stainless steel or other approved material, and of sizes as specified herein.
- (e) Subject to paragraph (f), all flushing devices installed on or after 1 January 1993, for use with water-closet pans shall be of the 6/3 litre dual-flush type.
- (f) If a flushing device installed before 1 January 1993, for use with a water-closet pan (in this paragraph called **“the old device”**) is to be replaced and the water-closet pan with which the old device is used cannot be efficiently cleansed with a flushing device of the 6/3 litre dual-flush type, an approved flushing device other than a device of that type may be installed by way of replacement for the old device.

*[By-law 19.3.1 amended in Gazette 22 December 1989 p.4622;  
3 January 1992 p.34; 31 December 1992 p.6415;  
29 December 1995 pp.6324-5.]*

**bl. 19.3**

---

19.3.2 Flushing-Cisterns

- (a) Flushing-cisterns shall be of an approved design, fitted with separate float control valves and overflows.
- (b) Where specified by the Corporation water supply to flushing-cisterns shall be from an approved storage tank.
- (c) Cisterns shall be firmly fixed to their supports by an approved means.
- (d) The water supply to a cistern shall be controlled by a separate stop-tap fixed as near as practicable to the cistern and within the same room or enclosure.
- (e) The cistern shall be connected to the water supply pipe by means of 15 mm copper tube, or other approved connection.
- (f) If a cistern is concealed from view a removable panel sized to facilitate maintenance of the cistern shall be provided.

*[By-law 19.3.2 amended in Gazette 22 December 1989 p.4622; 29 December 1995 pp.6324-5.]*

*[19.3.3. Repealed in Gazette 25 August 1998 p.4734.]*

*[19.4—19.8. Repealed in Gazette 25 August 1998 p.4734.]*

*[20.0, 21.0, 22.0, 23.0, 24.0. Repealed in Gazette 25 August 1998 p.4734.]*

## **25.0 Property sewerage design and installation**

*[By-law 25.0 amended in Gazette 24 December 1982 p.4928;  
Corrigendum in Gazette 4 February 1983 p.425.]*

*[25.1—25.6. Repealed in Gazette 25 August 1998 p.4734.]*

### **25.7 Excavation, bedding and property sewer installation**

*[By-law 25.7 amended in Gazette 24 December 1982 p.4928.]*

#### **25.7.1 Protection of Trenches**

An excavation exceeding 1.5 m in depth, or less in depth but where the sides are not self supporting, shall comply with the requirement of the relevant Construction Safety Acts and Regulations that such trenches be adequately supported against collapse. The Corporation may refuse to inspect or test any installation where the excavation is not so supported.

*[By-law 25.7.1 amended in Gazette 29 December 1995  
pp.6324-5.]*

#### **25.7.2 Width of Trenches**

Trenches shall be made with a clearance of not less than 100 mm on each side of the pipe measured to the inside timbers or trench. The trench width to the level of the top of the pipe shall be kept as narrow as possible.

#### **25.7.3 Explosives**

Explosives shall be used for the excavation of trenches only when approved by all relevant Authorities, and in accordance with conditions they may specify.

#### **25.7.4 Dewatering**

Dewatering of trenches shall be carried out by pumping so as to lower the water level below the barrel of the pipes to be laid and to ensure a firm base. Ground water shall not be discharged into the connection or sewer. The water level shall be maintained

**bl. 25.7**

---

below the level of the barrel of the pipes until such time as the trench or excavation has been backfilled completely.

**25.7.5** Laying of Property Sewers

Pipes shall be laid to the standards required by AS CA56, AS CA67 and AS CA68 using a practice approved by the Corporation.

*[By-law 25.7.5 amended in Gazette 24 December 1982 p.4928; 29 December 1995 pp.6324-5.]*

**25.7.6** Connecting to Corporation's Connection

- (a) Where a trench is excavated by machine, the section of the trench within 600 mm of the Corporation's connection shall be excavated by hand to prevent damage to the connection fittings.
- (b) When the stopper is removed from the connection fitting, care shall be taken to prevent the fitting being damaged.
- (c) If the connection is damaged the Corporation shall be informed as soon as possible and the fault rectified before the property sewer is laid.

*[By-law 25.7.6 amended in Gazette 24 December 1982 p.4928; 29 December 1995 pp.6324-5 and 6326.]*

*[25.8—25.15. Repealed in Gazette 25 August 1998 p.4734.]*



## 26.0 Jointing of pipes

*[26.1—26.3. Repealed in Gazette 25 August 1998 p.4734.]*

### 26.4 Materials and methods of jointing pipes and fittings

*[(a) and (b) deleted]*

*[26.4.1—26.4.7. Repealed in Gazette 25 August 1998 p.4734.]*

#### 26.4.8 Screwed Joints

*[(a) and (b) deleted]*

- (c) Where a sealing thread and a fastening thread are joined a seal shall be formed on metal threads by using polytetrafluoroethylene (PTFE) tape, hemp or pipe jointing compound and on plastic threads by using PTFE tape only.
- (d) Where 2 fastening threads are joined a seal shall be formed as in by-law 26.4.8(c) above or where applicable by an appropriate gasket or grummet.

*[By-law 26.4.8 amended in Gazette 24 December 1982 p.4929; 25 August 1998 p.4734.]*

*[26.4.9—26.4.12. Repealed in Gazette 25 August 1998 p.4734.]*

## **27.0 Sewerage services — general**

### **27.1 Procedure for connections to sewer**

When a sewer is completed and ready for use, action may be taken under sections 59 and 60 of the Act.

### **27.2 Proof of connections having been made. Certificate of Corporation's officer**

The certificate of such officer as the Corporation may appoint, in writing, shall be *prima facie* evidence that a water-closet or water-closets, or drains, appliances, apparatus and connections have been provided or that the works, matters and things have been performed, as the case may be, and *prima facie* evidence as to the amount of costs, expenses, and interest recoverable in respect thereof.

*[By-law 27.2 amended in Gazette 29 December 1995 pp.6324-5.]*

### **27.3 Plans required for property sewerage installation and fees for examination of plans**

*[By-law 27.3 inserted in Gazette 29 June 1984 p.1812.]*

#### **27.3.1 Interpretation**

In by-laws 27.3.2 and 27.3.3 “**exempt building**” means —

- (a) a single occupancy dwelling;
- (b) a residential or industrial development containing not more than 8 units; or
- (c) a commercial development of not more than 160 fixture units.

*[By-law 27.3.1 inserted in Gazette 29 June 1984 p.1812.]*

**27.3.2 Notice of Proposed New Works**

A person who proposes to erect a new building or to make alterations or additions to such a building shall —

- (a) give to the Corporation notice of that erection, alteration or addition in the form of a form approved by the Corporation;
- (b) furnish to the Corporation 2 copies of a plan of the building in a form acceptable to the Corporation; and
- (c) where the building is not an exempt building, furnish to the Corporation a plumbing design plan in a form acceptable to the Corporation.

Where any change to the siting of the building is made prior to local authority approval, or where local authority approval is conditional upon any change to the siting of the building, the plans (showing the proposed re-siting) shall be resubmitted to the Corporation prior to any work starting on the building.

*[By-law 27.3.2 inserted in Gazette 29 June 1984 p.1812; amended in Gazette 1 July 1993 p.3246; 29 December 1995 pp.6326-7.]*

**27.3.3 Existing Buildings**

The owner or occupier of an existing dwelling who proposes to have constructed or altered any property sewer, or to have fixtures on that property connected to, or other work of a sanitary nature carried out for connection to, the Corporation's sewerage system shall —

- (a) give to the Corporation notice of the connection in the form of a form approved by the Corporation;
- (b) furnish to the Corporation 2 copies of a plan in a form acceptable to the Corporation showing the location of the building in relation to the boundaries of the land and showing the location and level of the proposed fixtures; and

**bl. 27.4**

---

- (c) where the building is not an exempt building, furnish to the Corporation a plumbing design plan in a form acceptable to the Corporation.

*[By-law 27.3.3 inserted in Gazette 29 June 1984 p.1812; amended in Gazette 28 June 1985 p.2348; 22 December 1989 p.4635; 29 December 1995 pp.6326-7 and 6327.]*

**27.3.4 Fees**

- (a) In this by-law “**major fixtures**” includes water closets, urinal outlets, slop hoppers, pan washers and industrial waste outlets.
- (b) The fees to be paid in respect of proposals to carry out plumbing works are as set out in item 1 of Schedule C;
- (c) Fees will be assessed and are payable at the time of lodgement of a notice under by-law 27.3.2(a) or by-law 27.3.3(a).

*[By-law 27.3.4 inserted in Gazette 29 June 1984 p.1812; amended in Gazette 14 July 1984 p.2656; 28 June 1985 p.2348; 27 June 1986 p.2131; 29 June 1988 p.2166.]*

**27.3.5** Scale of Plans: All plans submitted shall be drawn to a scale of not less than 1:200.

**27.3.6.** Fees for installation of sewer junction: The fees to be paid by an owner in respect of the installation of an additional sewer junction are as set out in item 2 of Schedule C.

*[By-law 27.3.6 inserted in Gazette 29 June 1988 p.2126.]*

**27.4 Diagram of existing property sewers**

A person may make application to the Corporation for a diagram of existing property sewers in any area the plans or records of which are in the custody of the Corporation, and on payment of such sum as the Corporation requires, be supplied

by the Corporation with a diagram of the existing property sewers in that area in accordance with those plans and records.

*[By-law 27.4 amended in Gazette 24 December 1982 p.4929; 29 December 1995 pp.6324-5.]*

**27.5 Plan to be available to the Corporation**

An approved plan of proposed plumbing work shall be produced whenever required during the progress of work, to the Corporation.

*[By-law 27.5 inserted in Gazette 29 June 1984 p.1812; amended in Gazette 29 December 1995 p.6323.]*

**27.6 Notice and plan of intended new building or additions etc. to existing building**

A person intending to erect a building, or rebuild, or to make any addition or alteration to any building, adjacent to the Corporation's sewers shall give to the Corporation at least 14 days' notice of such intention, and with such notice shall submit for approval 2 copies of the building plan and shall also submit sections of such intended building, additions or alterations, drawn to a scale of not less than 1:200 showing the position of proposed fixtures and approaches thereto. When required by the Corporation enlarged details to such scale as instructed shall be supplied.

Where any change to the siting of the building is made prior to local authority approval, or where local authority approval is conditional upon any change to the siting of the building, the plans (showing the proposed re-siting) shall be resubmitted to the Corporation prior to any work starting on the building.

*[By-law 27.6 amended in Gazette 1 July 1993 pp.2346-7; 29 December 1995 pp.6324-5, 6326 and 6326-7.]*

*[27.7. Repealed in Gazette 28 June 1985 p.2351.]*

**bl. 27.8**

---

**27.8 Use of property sewers**

The owner and the occupier of a sewered property shall discharge into the sewerage system all faecal matter, urine, household slops, and household liquid refuse from such property and such other polluted water from stables, washing areas, manure bins, basements, cellars and roofed yards and, subject to these by-laws such industrial wastes as the Corporation has consented in writing to being so discharged.

*[By-law 27.8 amended in Gazette 24 December 1982 p.4929; 29 December 1995 pp.6324-5.]*

*[27.8.1. Repealed in Gazette 21 September 1990 p.4952.]*

**27.8.2 Water Test —**

- (a) The water test shall be applied to the property sewerage and plumbing systems and their fittings in their entirety or in sections, and shall be applied by hermetically sealing all openings below the top of the section to be tested. The system shall then be filled with water to the highest point of the section, or, if considered necessary, to such additional height as the responsible officer may order, and every joint, fitting and pipe carefully examined for leaks.
- (b) In testing stoneware or concrete property sewers a loss allowance at the rate of 2½% per hour of the capacity of the property sewer under test and at 1.5 m head shall be permitted.

*[By-law 27.8.2 amended in Gazette 24 December 1982 p.4929.]*

**27.8.3 Smoke Test**

The smoke test shall be applied by forcing into the system thick smoke to a pressure of 25 mm of water by means of a smoke test apparatus, closing all openings at which smoke appears and maintaining the pressure for 5 minutes after the last opening is

closed. Every joint or pipe shall then be carefully examined for leaks.

*[27.8.4. Repealed in Gazette 21 September 1990 p.4952.]*

**27.8.5 Defective Work**

Materials, pipes, bends, junctions, fittings, fixtures, and apparatus found to be defective shall be removed and replaced by sound ones, and defective joints made tight and every part of the work shall be made to comply to these by-laws and shall be subject to the approval of the Corporation.

*[By-law 27.8.5 amended in Gazette 29 December 1995 p.6323.]*

*[27.8.6. Repealed in Gazette 22 December 1989 p.4636.]*

**27.8.7 Maintenance by Occupier**

A silt trap, grease trap, oil trap or neutralizer, and such other appliance as the Corporation may direct, shall be maintained by the owner or occupier at his own expense and shall be cleaned at such intervals as may be necessary to ensure that such trap or appliance operates in an efficient and hygienic manner.

*[By-law 27.8.7 amended in Gazette 29 December 1995 pp.6324-5.]*

**27.8.8 Separate or Common Property Sewers —**

- (a) A house shall be separately served unless a common property sewer is ordered or approved by the Corporation.
- (b) Where a common property sewer is ordered or approved by the Corporation, the provisions of section 70 of the Act, as other conditions required by the Corporation, shall apply.

*[By-law 27.8.8 amended in Gazette 24 December 1982 p.4929; 29 December 1995 pp.6324-5.]*

**bl. 27.9**

---

**27.8.9** Provision of Water Closets —

- (a) At least one water closet approved by the Corporation shall be provided for each house, flat, building or land required by notice from the Corporation to be connected with the Corporation's sewer.
- (b) After the date fixed by notice from the Corporation to the owner of any house, building or land, requiring him to connect the same with the Corporation's sewer, or after such further time as shall be allowed by the Corporation, for the purpose of such connection, no privy closet other than a water closet approved by the Corporation, shall be used in such house or building or upon such land.

*[By-law 27.8.9 amended in Gazette 29 December 1995 pp.6324-5 and 6326.]*

**27.9** **Sewerage services to non-rateable properties**

Applications for sewerage services to non-rateable properties shall be made on the prescribed form procurable at the Head or Branch Offices and the Corporation may provide a service on payment of the prescribed annual fee, of the cost of extending the sewer to the land if the sewer is not extended thereto and of installing a property sewer to the boundary of the land. The applicant shall also bear the cost of maintaining the property sewer and of having it sealed when the service is no longer required.

The annual fee shall take the place of a sewerage rate and the general provisions of these by-laws shall apply to such services.

*[By-law 27.9 amended in Gazette 24 December 1982 p.4929; 29 December 1995 pp.6324-5.]*

**INDUSTRIAL WASTES AND PLUMBING BY-LAWS NOT  
INCLUDED IN PARTS 14 TO 24 INCLUSIVE**



## **28.0 Industrial wastes**

### **28.1 Conditions of Discharge**

The discharge of industrial wastes into a sewer shall be subject to the following terms, provisions and conditions: —

- (a) An application for permission to discharge industrial wastes from a property into a sewer shall be made in writing to the Corporation and shall set out —
  - (i) the processes of manufacture from which industrial wastes are discharged into the Corporation's sewer;
  - (ii) the nature of the industrial waste from every such process;
  - (iii) the estimated maximum rate of discharge of industrial waste from every such process;
  - (iv) the hours of the day during which discharge of industrial wastes from every such process will normally take place; and
  - (v) the estimated maximum daily discharge of such industrial wastes into the Corporation's sewer,

and the application shall be accompanied by detailed plans of the apparatus to be used for the treatment of the industrial waste and by such other information regarding the nature, quantity, rates, and times of discharge as may be required by the Corporation;

- (b) No industrial waste shall be discharged into the Corporation's sewer unless a written permit has been first granted by the Corporation, and an agreement executed by the applicant containing a covenant to

**bl. 28.1**

---

comply with the conditions of the permit, which shall include the following conditions, namely: —

That if at any time in the opinion of the Corporation —

- (i) the quantity, quality, or rate of the discharge of the said industrial waste is not in compliance with the terms, provisions, or conditions of the permit;
- (ii) the occupier is not fully and faithfully performing and observing the terms, provisions, and conditions of the said permit and of this or any other by-law;
- (iii) the treatment apparatus is not in efficient working order; or
- (iv) any other breach of the agreement has been made,

the Corporation may serve a notice in writing upon the occupier of the property, by leaving it thereon or posting it addressed to him at the property, specifying the matter or matters in respect of which a breach has taken place, or as to which the occupier is in default, or concerning which there is any complaint by the Corporation, and the notice shall require the occupier to make good the same in all things to the satisfaction of the Corporation, within a period to be stated therein, from the date of service thereof, in the manner so specified, and the notice shall also state that the Corporation is at liberty to terminate and put an end to the permit; and, further, that if the requirements of the notice have not been complied with on the expiration of the period mentioned therein, the permit shall automatically terminate and be deemed to be at an end, save and except as to the power of entry by the Corporation's officers as mentioned in the permit without any further or other notice from the Corporation, and the Corporation by its officers may enter upon the property, and at the cost and expense in all things of the

- occupier disconnect the apparatus used to discharge the industrial waste into the Corporation's sewers, and prevent and put an end to the further entry of industrial waste to the sewers, and the occupier shall be entitled to no compensation whatever in connection therewith;
- (ba) A written permit to discharge industrial waste granted by the Corporation shall remain in operation until —
- (i) the permit is terminated under paragraph (b);
  - (ii) the permit is surrendered by the holder of the permit; or
  - (iii) there is a change of ownership or occupancy of the industrial property from which it is permitted to discharge that industrial waste, unless the Corporation approves of the assignment or transfer of the permit;
- (c) The Corporation shall be the sole judge as to the quality, quantity and rate of discharge of such industrial waste and as to whether the same complies with the conditions of the said permit and of Parts 6 to 25 of these by-laws and its decision in regard thereto shall be final and conclusive;
- (d) Except by special permission of the Corporation, in writing, the volume of industrial waste discharged from any property into a sewer of the Corporation shall not in any case exceed —
- (i) if the industrial waste is discharged into a 100 mm sewer of the Corporation, a discharge rate of 3 kilolitres per hour;
  - (ii) if the industrial waste is discharged into a 150 mm sewer of the Corporation, a discharge rate of 7 kilolitres per hour; or
  - (iii) if the industrial waste is discharged into a 230 mm sewer of the Corporation, a discharge rate of 11.5 kilolitres per hour;

**bl. 28.1**

---

(e) The maximum aggregate daily quantity of industrial waste which may pass from any property into a sewer, the size and capacity of the property sewer for conveying such industrial waste from the property to the sewer, and the hours during which such flow will be permitted, shall be determined by the Corporation. The volume of industrial waste discharged shall, if ordered by the Corporation, be determined by meter or by some approved means of measurement provided by the occupier;

*[(f) deleted]*

(g) All industrial wastes shall be passed through such settling, screening or neutralizing chambers or such other apparatus as ordered or approved by the Corporation or any one or more of those chambers or apparatus to ensure that the resulting effluent shall comply with the requirements of the said permit and of this by-law. All such apparatus or machinery shall be approve in type and general arrangement by the Corporation, but the applicant shall determine the size, capacity and details of the treatment apparatus necessary to provide an effluent in compliance with the requirements of the said permit and this by-law;

(h) The occupier shall notify the Corporation in writing of his desire to make any alteration which shall in any way affect: —

- (i) the nature of the waste from any process of manufacture;
- (ii) the estimated maximum rate of discharge from any such process of manufacture; or
- (iii) the hours of discharge of industrial waste from any such process; and all alterations or additions to the treatment apparatus shall in all things comply with the requirements of the said permit and of this by-law, but in no case shall any such

alteration be made without the approval in writing of the Corporation;

- (i) The person to whom the permit is granted shall notify the Corporation in writing of any change of ownership or occupancy of any industrial property connected with the Corporation's sewers, at least 14 days prior to such change;
- (j) The permit shall not be assigned or transferred, unless the consent thereto in writing of the Corporation has been first obtained;
- (ja) Any person who, before obtaining a permit from the Corporation, has entered into the ownership or occupation of any property from which has been discharged industrial waste which the Corporation has permitted a previous owner or occupier to discharge into a sewer, is not permitted to discharge industrial waste into a sewer unless —
  - (i) the Corporation has first permitted the assignment or transfer of the permit under which industrial waste was admitted into a sewer; or
  - (ii) the Corporation has granted a fresh permit to the incoming owner or occupier to discharge into a sewer industrial waste from that property;
- (jb) A person referred to in paragraph (ja) who discharges directly or indirectly industrial waste into a sewer before obtaining the permission of the Corporation or obtaining a fresh permit shall, in addition to any penalties prescribed in these by-laws, be liable for all amounts in respect of the discharge of industrial waste owing at the time that person entered into ownership or occupation of the property as well as such amounts as would have been payable in respect of any discharge of industrial waste after that time if that person had obtained a permit to discharge industrial waste;

**bl. 28.1**

---

- (jc) Neither the payment of an amount referred to in paragraph (jb) nor the acceptance of that amount by the Corporation shall in any way constitute permission to discharge industrial waste into a sewer;
- (k) The owner or occupier of any property connected with the Corporation's sewers shall, if and where directed, install to the Corporation's design an approved chamber for inspection, sampling, and measurement, and every such chamber shall at all times be readily accessible to the Corporation's officers;
- (l) The Corporation or any authorized officer, servant, agent, or workman, of the Corporation shall be at liberty at any time and from time to time to enter upon the property and every part thereof and take samples of industrial waste for analysis and otherwise and also to inspect the treatment apparatus;
- (m) Every settling, screening, or neutralizing chamber, or other apparatus for the treatment of industrial wastes in accordance with this by-law shall be cleansed and maintained by the occupier at his own expense and, at such intervals as may be considered necessary by the Corporation to ensure the efficient operation of such chamber or apparatus;
- (n) Notwithstanding the permission or approval of the Corporation, the occupier of a property shall be solely liable for and in respect of —
  - (i) accident or damage, loss, or injury directly or indirectly arising out of or resulting from the discharge of industrial waste from the property into the Corporation's sewer, and the occupier shall agree to hold harmless and keep indemnified the Corporation against all claims and demands for such damage, loss, or injury of any description made and/or suffered by the

workmen of the Corporation or any other persons whomsoever; and

- (ii) damage, loss, or injury occasioned by or done to the Corporation's sewer or to property belonging to the Corporation or to a Company, person, or persons by reason of such discharge failing to comply with the terms, conditions, and provisions of the said permit or of the by-laws of the Corporation, and the occupier shall pay the cost of making good any such damage, loss or injury;
- (o) The Corporation may from time to time without payment of any compensation exclude from its sewers all industrial waste from any property during the repairing, examination, or maintenance of the sewers or the carrying out by the Corporation of any works in connection therewith; and
- (p) Such other conditions as may be required by the Corporation having regard to the special circumstances of the case.

*[By-law 28.1 amended in Gazette 18 June 1982 p.2023; 24 December 1982 p.4929; 24 June 1983 p.2008; 29 June 1984 p.1813; 28 June 1985 p.2349; 27 June 1986 p.2131; 14 July 1987 p.2656; 19 February 1988 pp.551-2; 29 June 1988 pp.2126-7; 29 December 1995 pp.6324-5, 6326 and 6326-7; 4 February 1997 p.713.]*

## **28.2 Connections prior to by-law**

- 28.2.1 Subject to by-law 28.1, where the Board has, before the date of the coming into operation of this by-law, granted to a person permission to discharge industrial waste into a property sewer or into a sewer of the Board, or where a person has, before the date of the coming into operation of this by-law, been discharging industrial waste into a property sewer or into a sewer of the Board without the express permission of the Board, if after the said date,

**bl. 28.3**

---

such person continues so to discharge such industrial waste, the Corporation may, if it thinks fit and notwithstanding anything contained in these by-laws, by notice in writing, direct such person wholly to cease from discharging such industrial waste.

*[By-law 28.2.1 amended in Gazette 24 December 1982 p.4929; 29 December 1995 pp.6324-5.]*

28.2.2 A notice under by-law 28.2.1 of this by-law shall specify a day, not less than 8 weeks from the date of the notice as the day on and after which such person is directed to cease discharging such industrial waste.

28.2.3 A person who fails to comply with a direction contained in the notice commits an offence.

28.2.4 In this by-law —

“**Board**” means the former Metropolitan, Water Supply, Sewerage, and Drainage Board constituted under the *Metropolitan Water Supply, Sewerage and Drainage Act 1909*.

*[By-law 28.2.4 inserted in Gazette 29 December 1995 p.6323.]*

**28.3 Polluted areas**

28.3.1 Connection — The Corporation may by notice in writing require any owner or occupier of any land to which section 58 of the Act applies to connect with the sewer of the Corporation dairies, market-places, abattoirs, areas for washing vehicles, or other polluted areas upon such land.

*[By-law 28.3.1 amended in Gazette 29 December 1995 pp.6324-5.]*

28.3.2 Conditions Governing Connection — A connection of the kind referred to in by-law 28.3.1 shall not be made unless the following conditions have been complied with: —

- (a) The place, or places, to be connected, if of a total area greater than 17 square metres, shall be so roofed as to



prevent the entry of rainwater from it to the sewers, and in no case shall rainwater be permitted to discharge on to such place from adjoining surfaces;

- (b) The property to be connected shall be paved with concrete or other approved materials, with a 75 mm raised kerb and graded to the satisfaction of the Inspector; and
- (c) The property sewer from any such place shall be provided with an approved silt trap with a removable grating.

*[By-law 28.3.2 amended in Gazette 24 December 1982 p.4929.]*

**28.3.3 Prevention of Storm Water entering Yard Gullies —**

- (a) Stoneware yard gully basins and the top of silt traps provided with stoneware basins shall be so surrounded with an approved impervious kerbing of concrete or other approved material as to prevent the access of surface water to the property sewers, and if the Corporation so directs, the wall at the rear of a gully or silt trap, if of brick or stone, shall be cement rendered to the height of the top over same, and if of wood, the wall shall be provided with an approved galvanized sheet iron apron.
- (b) Rainwater pipes shall not be connected to or discharge into a gully or fixture connected to the Corporation's sewers.
- (c) Gullies or pits for the disposal of road drainage, or for the disposal of storm water from a roof, yard or vacant land shall not be connected to a sewer or property sewer under the control of the Corporation.

*[By-law 28.3.3 amended in Gazette 24 December 1982 p.4929; 29 December 1995 pp.6324-5 and 6326.]*

**bl. 28.3**

---

28.3.4 Sealed Disconnecter Traps:

- (a) Sealed disconnecter traps may be affixed inside or outside a building, or out-building, and in such cases breather pipes or fresh air inlet equal in area to the waste pipe or pipes discharging into the trap shall be taken to such height as directed.
- (b) Where the trap is inside the building or outbuilding such pipes shall be led to the outside of the building or outbuilding.
- (c) The material for the breather pipes shall be the same as for vent pipes.
- (d) Inspection openings to the traps shall be sealed with screwed plugs, or as otherwise approved.

28.3.5 Provision of Grease, Petrol, and Oil Traps

Wastes from the following fixtures and areas shall first discharge into an approved apparatus for retaining objectionable matter, that is to say: —

- (a) A fixture or area from which petrol, benzine or other inflammable or explosive substance, or grease, oil or greasy or oily matter, is likely to be discharged, or conveyed into waste, combined waste, or soil pipes or into property sewers;
- (b) A sink in food-packing houses, food preparation premises, butchers' shops, lard rendering establishments, hotels, motels, restaurants, boarding houses, and such other places as the Corporation may direct; and
- (c) Such other fixtures, areas or apparatus as the Corporation may direct.

*[By-law 28.3.5 amended in Gazette 24 December 1982 p.4929; 29 December 1995 pp.6324-5.]*

28.3.6 Construction of Grease Traps:

- (a) Grease traps shall be fixed outside buildings or outbuildings wherever practicable.
- (b) External grease traps shall be constructed of approved materials.
- (c) Internal grease traps shall be constructed of copper, stainless steel, or other approved material, and, if directed fixed upon a tray.
- (d) The outlet from a grease trap shall be connected to a disconnecter trap.

28.3.7 Grease Trap Ventilation

Internal and external grease traps shall have approved independent provision made for inlet and outlet ventilation as provided for waste pipes in by-law 28.9.12.

*[By-law 28.3.7 amended in Gazette 24 December 1982 p.4929.]*

28.3.8 Size of Grease Trap:

- (a) The dimensions of a grease trap to be provided shall be such as to ensure the retention of all grease entering such trap.
- (b) The height from the top of the outlet of a grease trap to the vent take off shall not be less than 100 mm.
- (c) The difference in level between invert of inlet and invert of outlet shall be not less than 25 mm.
- (d) The capacity of a sink shall be measured to the overflow level, or, in the event of there being no overflow, to the top of the sink.
- (e) Where hot water is being fed to a dishwasher the capacity of the dishwasher shall be taken as the amount of maximum hourly discharge.

**bl. 28.3**

---

**28.3.9** Outlet Pipes from Grease Traps

The outlet pipe from a grease trap shall be at least equal to the size of the pipe which has a cross sectional area equivalent to the total area of incoming waste pipes and unless the Corporation so permits shall not be less than 65 mm in diameter.

*[By-law 28.3.9 amended in Gazette 29 December 1995 pp.6324-5.]*

**28.3.10** Construction of Petrol and Oil Traps

- (a) Petrol and oil traps shall be constructed in accordance with the Corporation's type drawings.
- (b) Such traps shall be connected to a disconnecter trap and shall be provided with independent ventilation.

*[By-law 28.3.10 amended in Gazette 29 December 1995 p.6326.]*

**28.3.11** Construction of Silt Traps, Bucket Traps and Potato Peeling Machine Traps

Construction of silt traps, bucket traps, and potato peeling machine traps shall be in accordance with the Corporation's Standard Drawings and be sized to the requirements of the Corporation.

*[By-law 28.3.11 amended in Gazette 29 December 1995 pp.6324-5 and 6326.]*

**28.3.12** Venting of fixtures and fittings discharging into grease traps

- (a) Irrespective of the length of the wastepipe, kitchen or scullery sinks and dishwashers discharging into grease traps shall be vented.
- (b) Unless the length of the wastepipe exceeds 6 metres, bucket traps discharging into grease traps need not be vented.

28.3.13 Potato Peeling Machines

Potato peeling machines shall be fixed to a floor of impervious material of approved grade or slope and shall drain to and discharge into a silt trap through a screen or mesh of non-corrodible material of not less than 4 meshes to 25 mm.

**28.4 Prohibited discharges**

The depositing or discharge of the following substances into a property sewer or sewer without prior approval of the Corporation, shall be an offence against these by-laws, namely: —

- (a) Animal matter, other than as mentioned in by-law 28.3.1, fleshing, wool, hair, dead animal, grease, dust, ashes, rubbish, garbage, offal, vegetable and fruit or their parings, rags, oil, fat, mud, sand, gravel, or like substance, or any other substance which is, in the opinion of the Corporation, liable to be injurious to any part of the sewerage system or to officers or agents of the Corporation engaged in the operation of maintenance of the sewerage system;
- (b) Petrol or other inflammable or explosive substance, whether solid, liquid or gaseous;
- (c) Rain, roof, surface, river or flood waters, except by special permission in writing under the hand of the Corporation;
- (d) The contents of a nightsoil cart, cesspool, or privy;
- (e) Industrial waste or any substance which has a pH outside the range of 6.2 to 9.0;
- (f) Industrial waste which is above the temperature of 38 degrees Celsius or such lower temperature as may be prescribed by the Corporation, having regard to the special circumstances of a particular case;

**bl. 28.4**

---

- (g) Liquid which contains such percentage of common salt, or of other mineral, salt, acid, solvent or gas, as in the opinion of the Corporation, is injurious to, or liable to form compounds injurious to any part of the sewerage system or to employees of the Corporation engaged in the operation or maintenance of the sewerage system;
- (h) Water from a steam exhaust, blow off drip pipe or condenser;
- (i) Radio-active substances beyond the safe limits prescribed by the Radiological Council of Western Australia; and
- (j) Unless the discharge has been thoroughly disinfected, solid or liquid discharge from patients suffering from any infectious or contagious disease.

*[By-law 28.4 amended in Gazette 24 December 1982 p.4929; 29 December 1995 pp.6323 and 6324-5.]*

bl. 28.4

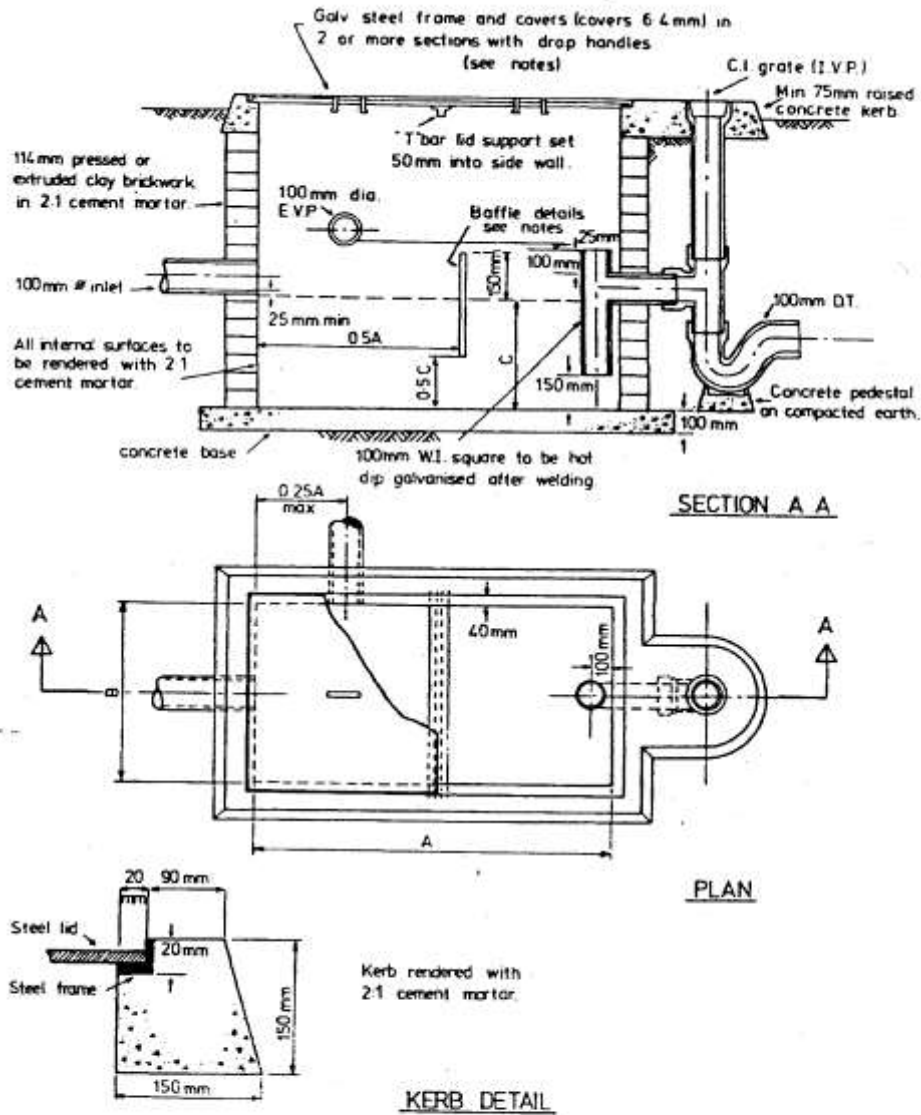

**FIG 28.1 GREASE TRAP CONSTRUCTION**

**bl. 28.4**

---

DESIGN NOTES

- 1 Sizes and application — See note 3 for dimension.
  - (a) Size 1 — Fried fish shops with maximum of 2 fixtures and 1 bucket trap.
  - (b) Size 2 — Small restaurants, works canteens, small hospital kitchens, licensed premises serving meals but with limited accommodation facilities and small butcher shops.
  - (c) Size 3 — Large supermarket butcher shops, major hospital kitchens, large accommodation hotel kitchens small food manufacturing premises.
- 2 Other applications not covered in 1(a), 1(b) and 1(c) must be discussed with the Industrial Waste Section.
- 3 Trap dimensions and construction notes.

(a)

Dimensions mm	Size 1	Size 2	Size 3
A	900	1200	1800
B	450	600	750
C	300	450	450

- (b) Sizes 1 and 2 to have 2 covers of equal size, size 3 to have 3 covers of equal size, and set in steel frame
- (c) Baffle to be 22 mm thick slate, 6.3 mm M.S. plate (nylon, epoxy resin, or p.v.c. dipped), or 12.6 mm p.v.c.

**FIG 28.2 GREASE TRAP CONSTRUCTION NOTES**



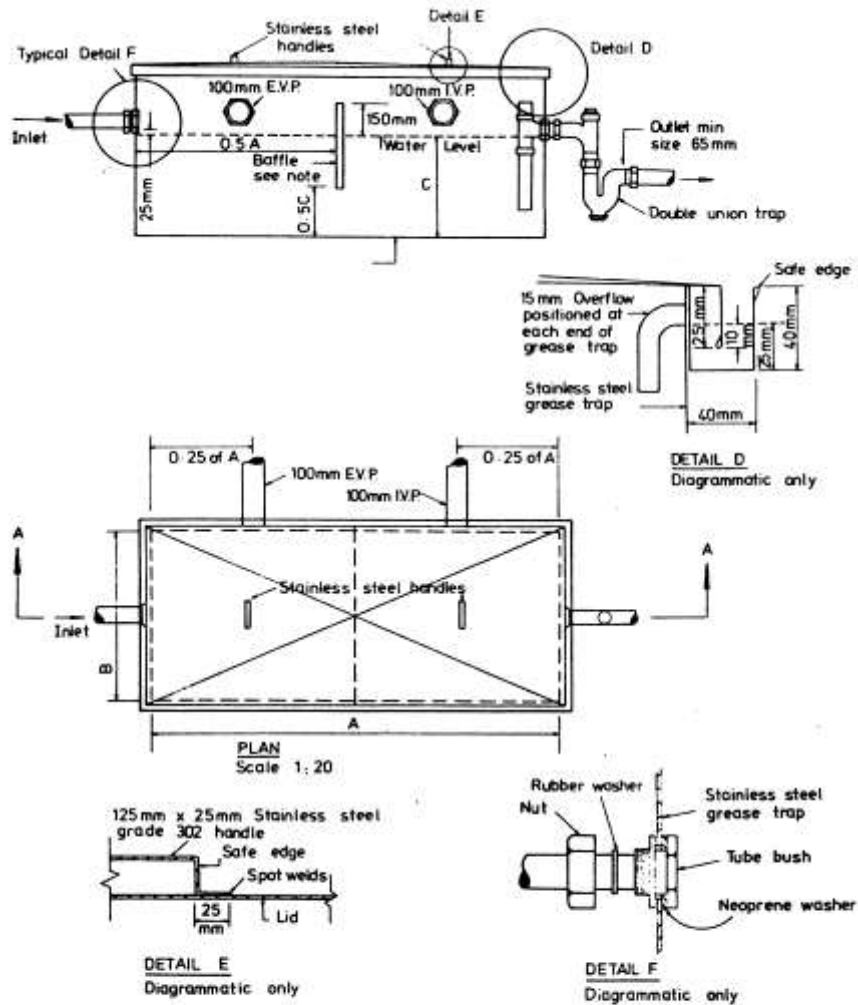

**FIG. 28.3 PREFABRICATED GREASE TRAP CONSTRUCTION.**

**bl. 28.4**

---

DESIGN NOTES

- 1 Sizes and application — See note 3 for dimension.
  - (a) Size 1 — Fried fish shops with maximum of 2 fixtures and 1 bucket trap.
  - (b) Size 2 — Small restaurants, works canteens, small hospital kitchens, licensed premises serving meals but with limited accommodation facilities and small butcher shops.
  - (c) Size 3 — Large supermarket butcher shops, major hospital kitchens, large accommodation hotel kitchens, small food manufacturing premises.
- 2 Other applications not covered in 1(a), 1(b) and 1(c) must be discussed with the Industrial Waste Section.
- 3 Trap dimensions and construction notes.

(a)

Dimensions mm	Size 1	Size 2	Size 3
A	900	1200	1800
B	450	600	750
C	300	450	450

- (b) Where internal grease traps occur on impervious floors graded to a floor waste an overflow tray is not required.
- (c) Where trays are required the tray size shall be fabricated from grade 302 0.55 mm sheet stainless steel and have 80 mm of clearance surrounding the trap with 80 mm upstand and a safe edge. A 50 mm overflow pipe shall discharge from the overflow tray (if required) to a conspicuous position outside the building or where otherwise directed by M.W.S.S. & D.B. Plumbing Inspector.

- (d) All welds to be polished to a satin finish & left in as new condition.
- (e) Grease trap to be fabricated from grade 302 0.7 mm stainless steel on 1 & 2 but 0.9 mm on size 3.
- (f) Lid to be crimped for strength (see plan) on size 1 2 & 3 but size 3 to have strengthening rib incorporated in lid.
- (g) Baffle to be formed from grade 302 0.7 mm stainless steel in each type.
- (h) Inlet and outlet sizes to be in accordance with M.W.S.S. & D.B. by-law 133.
- (i) 8 mm charge pipe to discharge into water seal from nearest low pressure point.

FIG 28.4 PREFABRICATED GREASE TRAP CONSTRUCTION  
NOTES

bl. 28.4

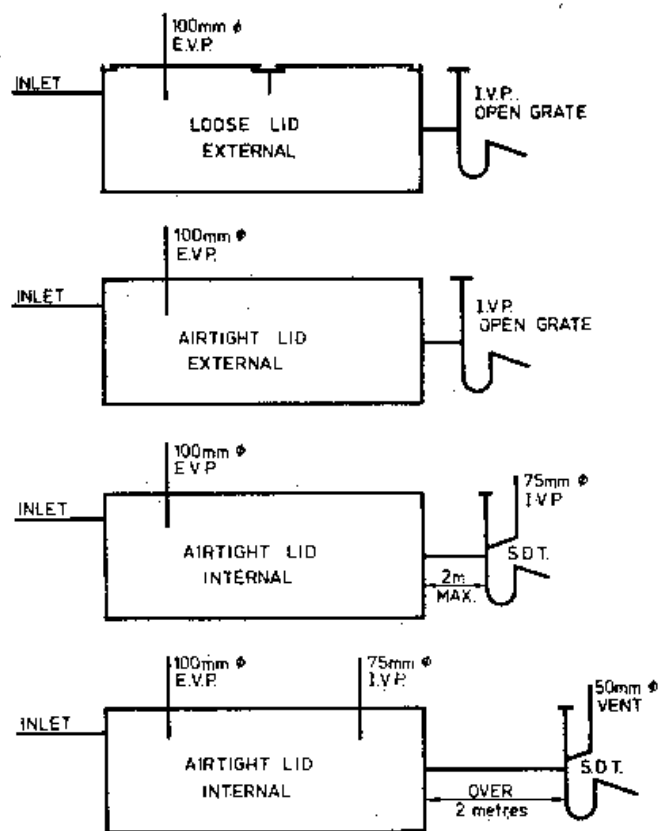

INDUSTRIAL WASTE ARRESTOR I.V.P. AND E.V.P.  
NOT TO BE COMBINED

FIG.28.5 VENTING OF INDUSTRIAL WASTE ARRESTORS

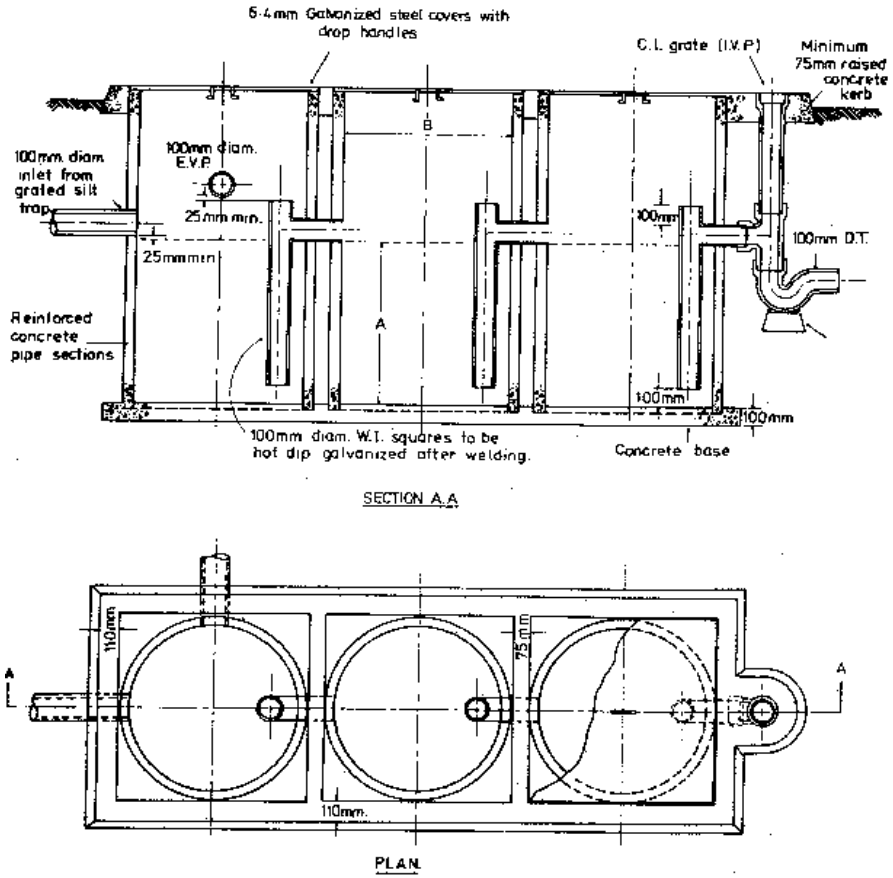

FIG. 28.6 PETROL AND OIL TRAP  
CONSTRUCTION

**bl. 28.4**

---

DESIGN NOTES

- 1 Sizes and applications — See note 3 for dimensions.
  - (a) Size 1 — Small mechanical workshops, carrying out small engine servicing with 1 silt sump.
  - (b) Size 2 — Average sized service stations with 1 silt sump and lube bay area.
  - (c) Size 3 — Large service stations with 2 to 4 silt sumps, lube bay areas and manual vehicle wash area.

2 Other applications not covered in 1(a), 1(b) and 1(c) must be discussed with the Industrial Waste Section.

3 Trap dimensions and construction notes.

(a)

Dimension mm	Size 1	Size 2	Size 3
A	600	900	900
B (Dia)	600	600	900

- (b) 3 Pipe sections to be used in each case.
- (c) Pipe sections to be set 25 mm. into concrete base.
- (d) Each pipe section to have square or round lid with one drop handle.

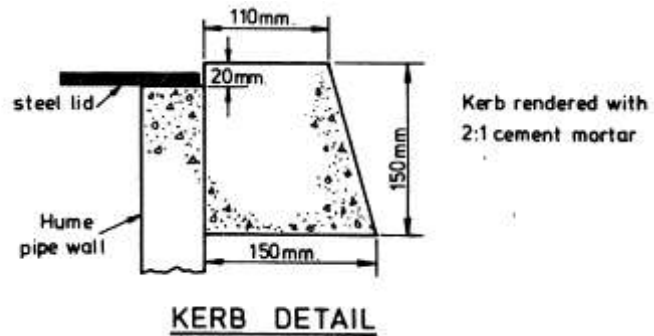

FIG. 28.7 PETROL AND OIL TRAP  
CONSTRUCTION NOTES

bl. 28.4

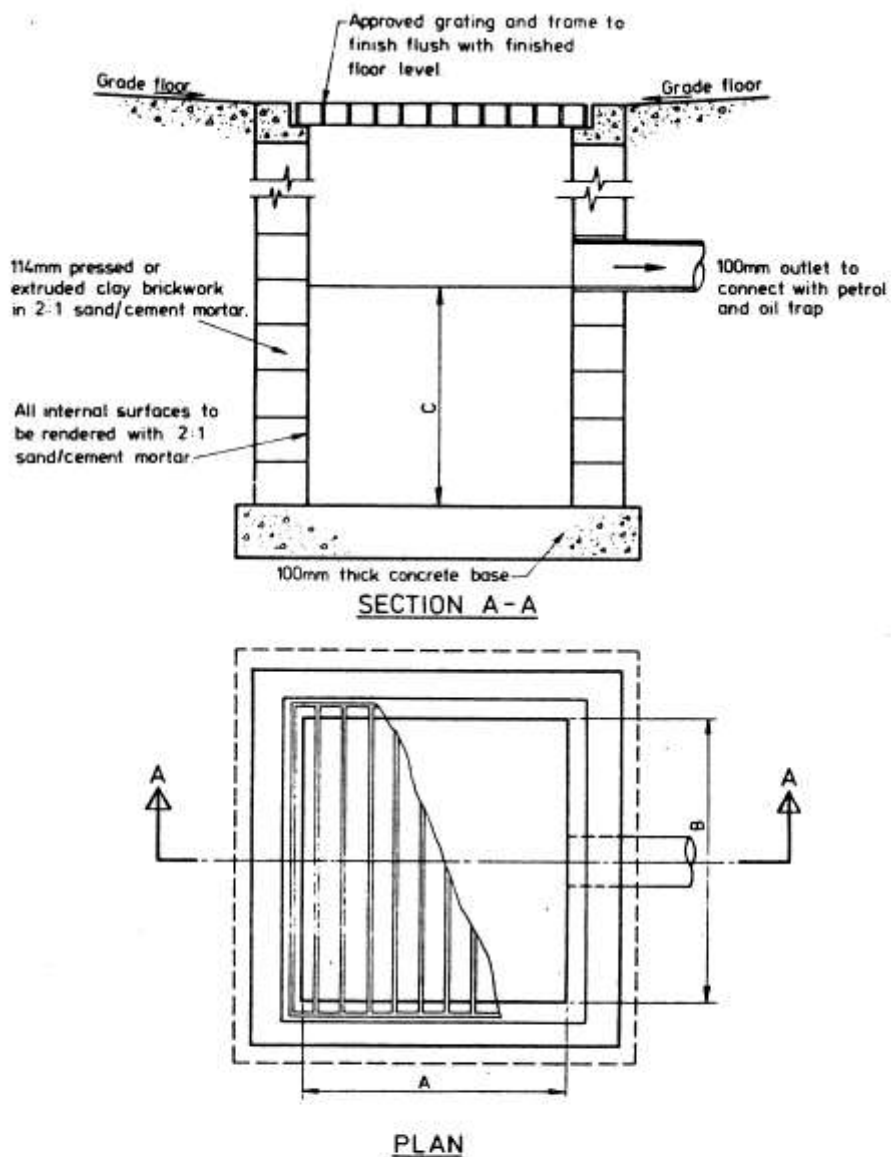

FIG. 28.8 SILT TRAP  
CONSTRUCTION



DESIGN NOTES

- 1 Sizes and application — See note 3 for dimensions.
  - (a) Size 1 — garage floor silt.
  - (b) Size 2 — manual car wash areas, garage engine parts wash areas.
- 2 Other applications not covered in 1(a) or 1(b) must be discussed with the Industrial Wastes Section.
- 3 Trap dimensions and construction

Dimensions mm	Size 1	Size 2
A	450	600
B	450	600
C	450	600

FIG 28.9 SILT TRAP CONSTRUCTION NOTES

bl. 28.4

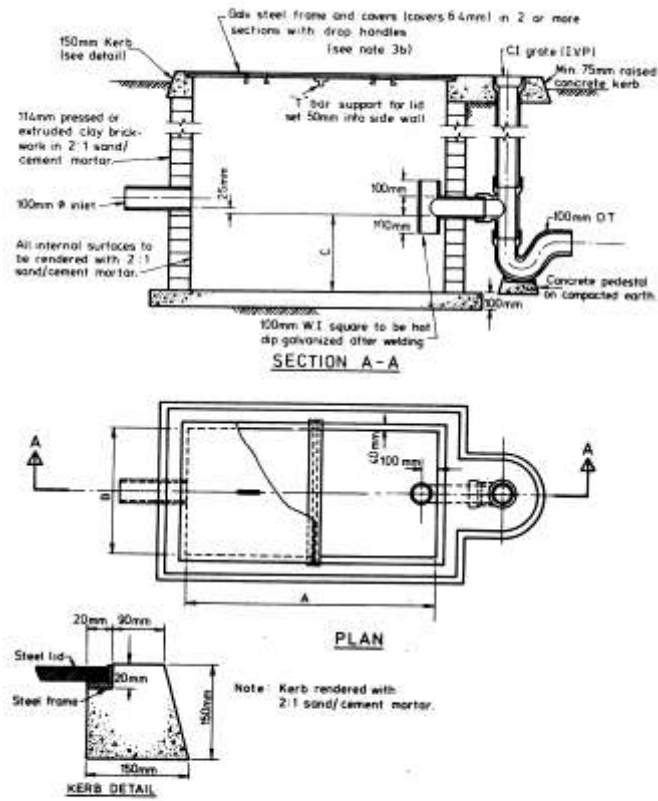

**FIG 28.10 SAND/PLASTER TRAP  
 CONSTRUCTION**

DESIGN NOTES

- 1 Sizes and applications — See note 3 for dimensions
  - (a) Size 1 — Beach shower room installations with up to 4 shower units.  
School plaster and clay rooms with up to 3 sinks.
  - (b) Size 2 — Beach shower room installations with up to 8 shower units.  
School plaster and clay rooms with up to 8 sinks.
- 2 Other applications not covered in 1(a) or 1(b) must be discussed with the Industrial Wastes Section.
- 3 Trap dimensions and construction notes
  - (a)

Dimension mm	Size 1	Size 2
A	1200	1800
B	450	600
C	600	600
  - (b) Size 1 to have 2 covers of equal size, size 2 to have 3 covers of equal size, and set in steel frame.

FIG 28.11 SAND/PLASTER TRAP CONSTRUCTION NOTES

bl. 28.4

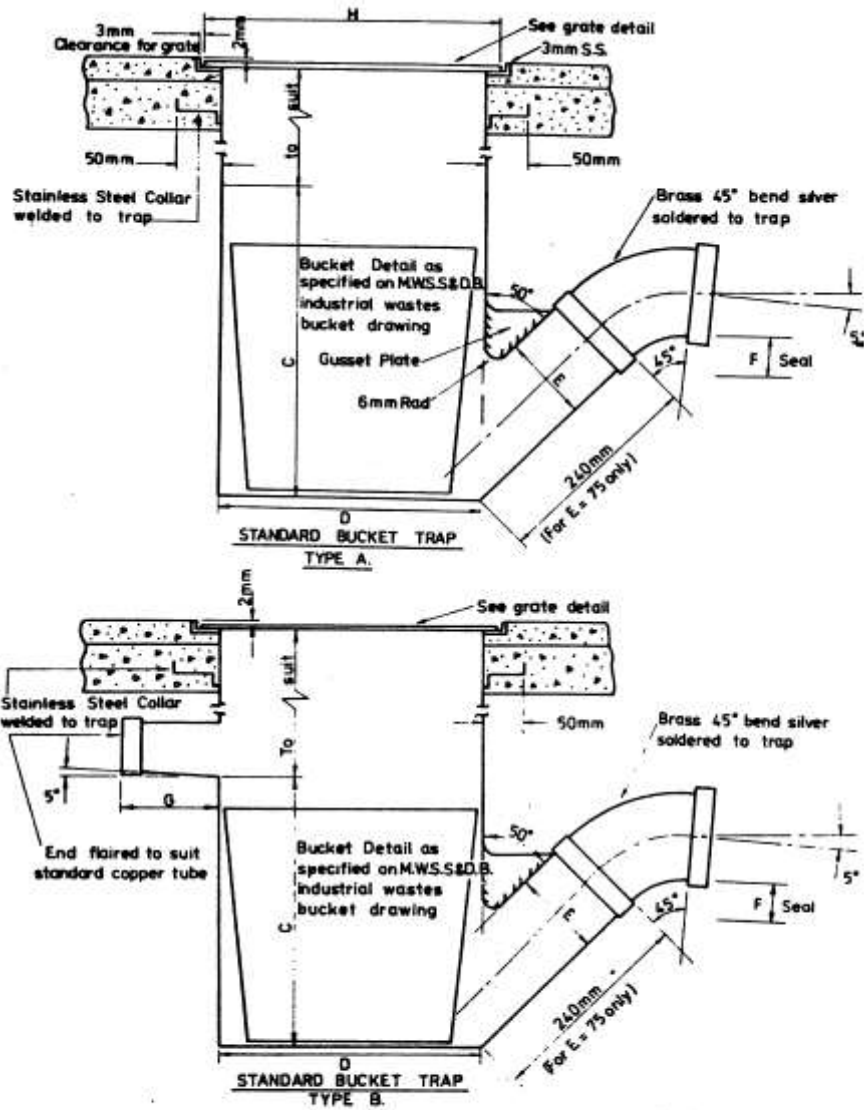

**FIG. 28.12 STAINLESS STEEL BUCKET TRAP CONSTRUCTION**

DESIGN NOTES

1) Trap & Grate dimensions

Bucket Trap Type	S.S. Thick- ness (mm)	Int Dia Dmm	Height to Inlet C mm	Outlet Dia E mm (Min)	Seal Fmm	Length of Inlet Gmm	GRATE	
							Dia Hmm	Thick- ness Jmm
A	1.6	225	-	75	65	-	265	5
B	1.6	225	350	75	65	75	265	5
A	1.6	300	-	75	65	-	350	5
B	1.6	300	350	75	65	75	350	5

2) Traps to be constructed of 16mm stainless steel  
 to conform to 18/8/MO standard

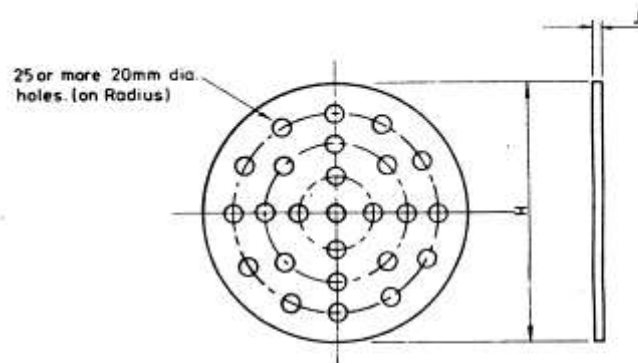

DETAIL OF STAINLESS STEEL GRATE

FIG. 28.13 STAINLESS STEEL BUCKET  
 TRAP. CONSTRUCTION NOTES

bl. 28.4

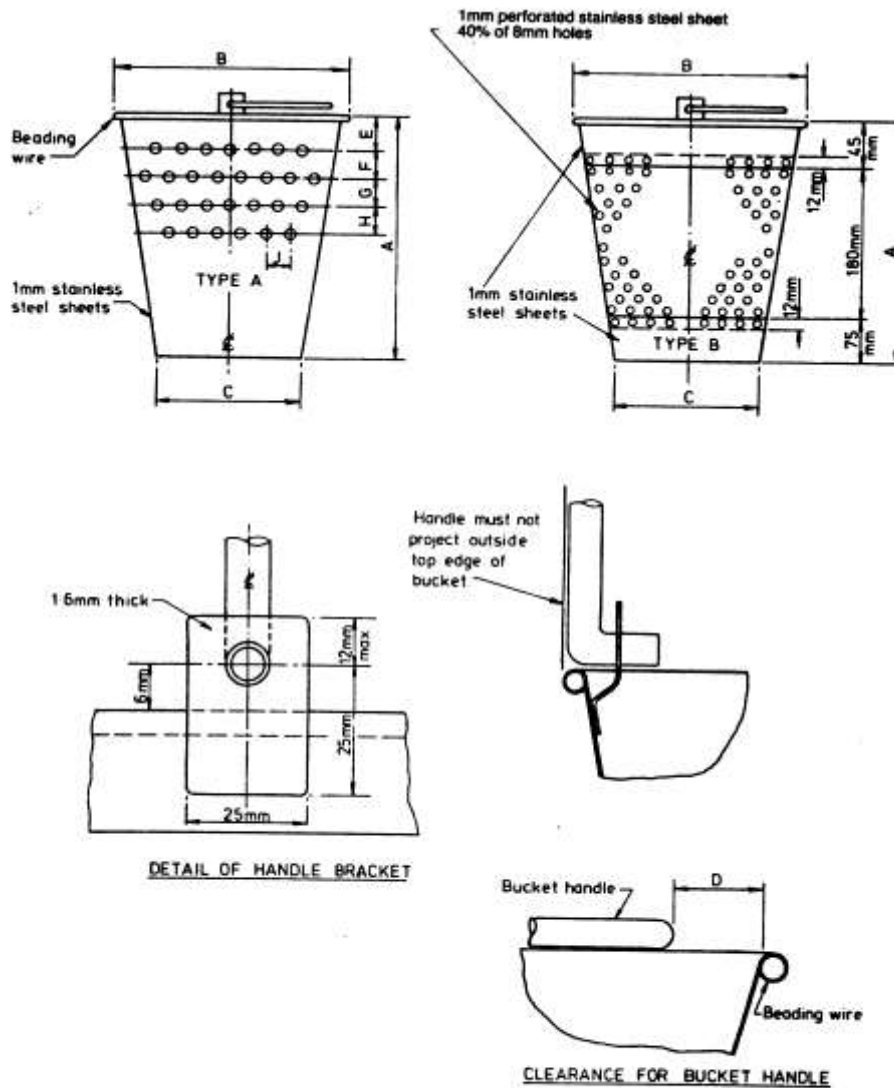

**FIG 28-14 STAINLESS STEEL BUCKETS  
CONSTRUCTION**

DESIGN NOTES

- 1 Sizes and applications:
  - (a) A1 — Plaster Traps, Bin Wash Areas, General Floor Wastes and Bottle Washing Machines.
  - A2 — For High Flow Applications which must be discussed with Industrial Wastes Section before specification.
  - (b) B — Fish shops, butchers shops, smallgoods and potato washing/peeling wastes.
- 2 Other applications not covered in 1(a) or 1(b) must be discussed with the Industrial Wastes Section.
3. Bucket Dimensions and Construction Notes:

Bucket No.	Material Thickness (mm)	A (mm)	B Dia (mm)	C Dia (mm)	D (mm)	Beading Wire Dia (mm)	Handle Rod Dia (mm)	Hole Details (mm)						
								No row	Dia (mm)	E	F	G	H	J
A1	1	300	218	180	10	5	6	4	6	25	30	30	30	30
A2	1	300	292	180	10	6	10	3	10	25	30	30	-	30
B	1	300	218	180	10	5	6	-	-	-	-	-	-	-

(b) Stainless Steel to be 18/8/MO grade.

FIG. 28.15 STAINLESS STEEL BUCKETS  
CONSTRUCTION NOTES

bl. 28.4

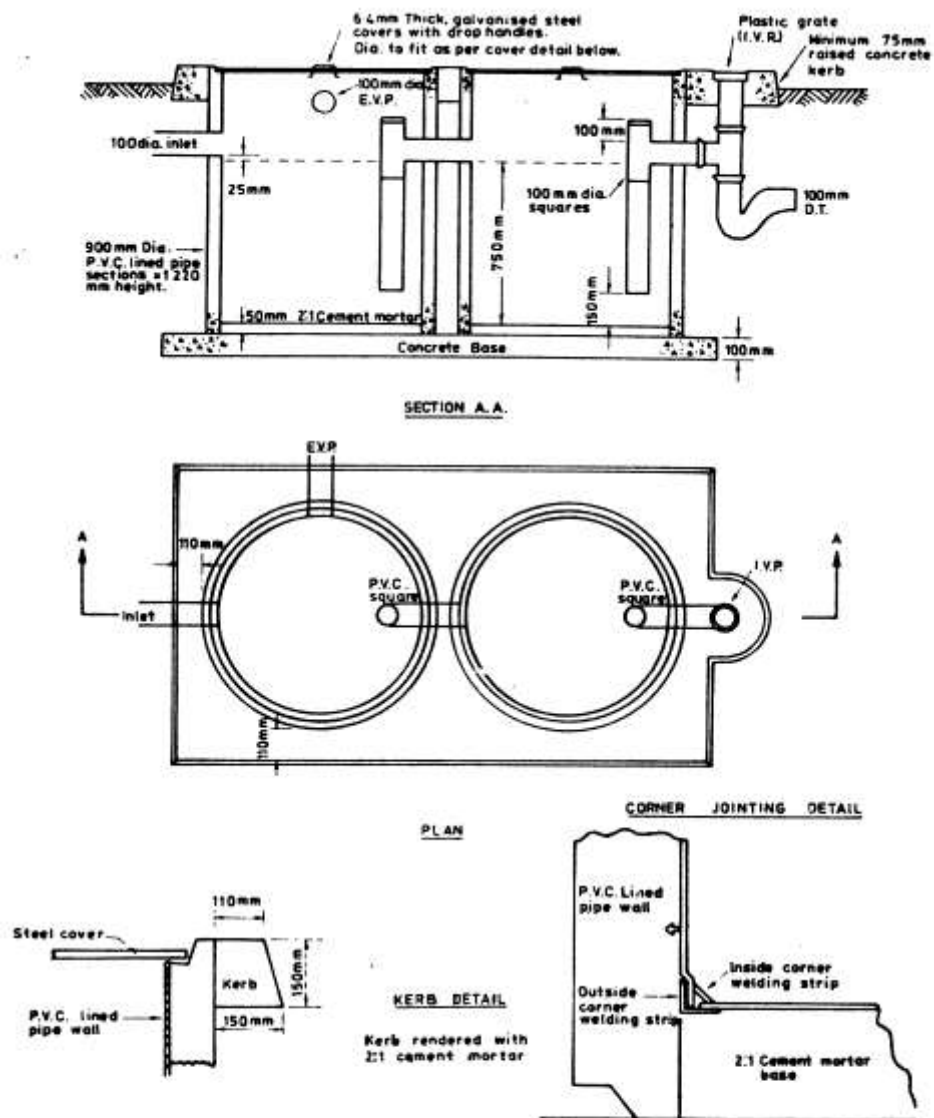

**FIG. 28.16 DILUTION / NEUTRALIZER TRAP  
 CONSTRUCTION**



DESIGN NOTES

- 1 Trap dimensions shown are minimum dimensions and cover laboratory installations with up to 20 sinks.
- 2 Other applications must be discussed with the Corporation's Industrial Waste Officer.
- 3 Two 900 mm nominal internal diameter P.V.C. lined spun concrete pipe sections to be used.
- 4 A P.V.C. base sheet to be welded to the P.V.C. lining of each pipe, using corner joint as shown in the standard drawing.
- 5 The welded joints to be spark tested in the presence of the Corporation's Industrial Waste Officer.
- 6 Other joints to be sealed with an epoxy resin.

FIG 28.17 DILUTION NEUTRALIZER TRAP  
CONSTRUCTION NOTES

*[Figure 28.17 amended in Gazette 29 December 1995 p.6323.]*

**28.5 Subsoil water**

Upon written application the Corporation may grant permission in writing to a person to discharge subsoil water into any property sewer or into any sewer of the Corporation subject to such terms and conditions as may be imposed.

*[By-law 28.5 amended in Gazette 24 December 1982 p.4929; 29 December 1995 pp.6324-5.]*

**28.6 Materials and fittings used in connection with the Corporation's works**

*[By-law 28.6 amended in Gazette 29 June 1984 p.1813.]*

**28.6.1 Fittings to be above Flood Level**

- (a) Inlets and openings shall not be in such positions that extraneous water, due to rise of subsoil water level, or

**bl. 28.6**

---

from a river, bay, gully or creek or any other source, whether in flood or otherwise, may gain access to the Corporation's sewers.

- (b) Without in any way limiting the generality of sub-by-law (a) in areas liable to be flooded or affected by rise of subsoil water level, persons shall not place in position for use any fitting, fixture, or apparatus having an inlet or opening into a property sewer or into a sewer of the Corporation unless the inlet or opening is above a level fixed by the Corporation for the particular district or locality as being a level providing a safe margin above the highest known subsoil water level or flood level.

*[By-law 28.6.1 amended in Gazette 24 December 1982 p.4929; 29 June 1984 p.1813; 29 December 1995 pp.6324-5 and 6326.]*

**28.6.2** Authorization of materials, fittings and fixtures

- (a) A material, fitting or fixture, other than a fixture of a kind described in Part 1 of Schedule D, shall not be connected to the works of the Corporation unless —
  - (i) it is a product that —
    - (A) is manufactured or supplied under a StandardsMark licence or a WaterMark licence granted by the Standards Association of Australia as a water or sanitary plumbing product intended for use in plumbing installations; and
    - (B) bears, or the packaging of which, bears the StandardsMark or WaterMark, as appropriate, of the Standards Association of Australia and the product or its packaging complies with such other marking requirements as are set out in the “Manual of Authorization Procedures for Plumbing and Drainage

Products, SAA MP52 — 1988”,  
published by that Association;

*[(ii) deleted]*

or

- (iii) it is the same as a material, fitting or fixture that is currently authorized for such connection by the Corporation under paragraph (e) and complies with any conditions as to marking imposed under that paragraph.
- (b) Notwithstanding compliance with paragraph (a)(i), a material, fitting or fixture of a kind described in Part 2 of Schedule D shall not be connected to the works of the Corporation.
- (c) Every application for authorization of a material, fitting or fixture for connection to the works of the Corporation shall be made in writing in a form acceptable to the Coordinator and shall be accompanied by —
  - (i) 2 copies of drawings in a form acceptable to the Coordinator;
  - (ii) unless exempted by the Coordinator, a sample of the material, fitting or fixture; and
  - (iii) the application fee set out in item 3(a) of Schedule C.
- (d) The Coordinator may, by notice in writing, require the applicant to provide details of test results and such other information as may be needed for the purpose of determining a particular application.
- (e) The Coordinator may, by notice in writing, give or refuse to give authorization to any material, fitting or fixture for connection to the works of the Corporation or may give such authorization subject to such conditions as the Coordinator thinks fit.

**bl. 28.7**

---

- (f) The Coordinator may, by notice in writing, vary, add to or remove conditions imposed under paragraph (e).
- (g) Where the Coordinator examines drawings submitted under paragraph (c)(i) or tests, inspects or evaluates a material fitting or fixture for the purpose of assessing its suitability for authorization, the fee set out in item 3(b) of Schedule C is payable by the applicant for the examination, test, inspection or evaluation.
- (h) In addition to the fee payable under paragraph (g), the applicant shall pay the reasonable costs of transport and accommodation incurred by the Coordinator in carrying out a test, inspection or evaluation.

*[By-law 28.6.2 inserted in Gazette 22 December 1989 p.4631; amended in Gazette 29 December 1995 pp.6326-7 and 6327; 25 August 1998 p.4734.]*

**28.6.3 Workmanship**

Work shall be executed in a thorough and tradesman like manner to the satisfaction of the Corporation.

*[By-law 28.6.3 amended in Gazette 29 December 1995 pp.6324-5.]*

**28.6.4 Protection of Workmen, etc.**

Adequate precautions shall be adopted, by persons carrying out work, to prevent injury to workmen, property, or the public, and the Corporation shall not be responsible for injury arising from the inadequacy of those precautions.

*[By-law 28.6.4 amended in Gazette 29 December 1995 pp.6324-5.]*

**28.7 Basement and cellar drainage**

**28.7.1 Risk of Back Flow**

- (a) Where a cellar, basement, or floor below ground level is at such a level as may, in the opinion of the Corporation,

involve risk of back flow in the event of the sewer becoming overcharged, the sewage from fixtures therein or on shall be raised by ejector, pump, or other approved mechanical appliance to such height as ordered, and discharged into the sewer as and where directed, by the Corporation.

- (b) Reflux Valves shall not be used as an alternative to pumping.

*[By-law 28.7.1 amended in Gazette 29 December 1995 pp.6324-5.]*

**28.7.2 Fixtures**

- (a) If approval is given for the connection of a cellar, basement or floor below ground level, no sink, trap, water-closet, urinal, or other fixture or apparatus shall be laid or fitted in the cellar or basement or on a floor below ground level unless the following conditions are complied with: —
  - (i) The consent, in writing, of the Corporation shall be first obtained, and may be revoked at any time;
  - (ii) The owner shall submit such information as may be required by the Corporation and shall undertake, in writing, on an approved form, to accept all liability for damage that may occur, and shall also give to the Corporation any indemnity that the Corporation may require; and
  - (iii) Such other conditions as may be required by the Corporation.
- (b) If on an inspection subsequent to connection:
  - (i) The fixtures and their surroundings are not in the opinion of the Corporation, being kept in a sanitary condition; or

**bl. 28.8**

---

- (ii) The purpose for which the cellar, basement or floor below ground level is used, has been changed,

then the Corporation may revoke its consent, and upon the expiration of 14 days from the date of revocation, if the defect has not been remedied, the closet, urinal, or other fixture shall be disconnected from the Corporation's sewers.

*[By-law 28.7.2 amended in Gazette 29 December 1995 pp.6324-5 and 6326.]*

**28.7.3** Seepage Drains

A seepage drain from a cellar, basement, or a floor below ground level shall not be discharged into a sewer without the consent of the Corporation. Where such discharge is permitted, the seepage shall be raised by ejector, pump or other approved mechanical appliance to such height as ordered and discharged into the sewer as and where directed.

*[By-law 28.7.3 amended in Gazette 29 December 1995 pp.6324-5.]*

**28.8** Safes and overflows

**28.8.1** Safes — where required

Where in the opinion of the Corporation there is a likelihood of damage being caused by the fixtures overflowing, unless the floor is constructed of concrete of not less than 100 mm thickness or of other approved impervious material, graded as directed, safes of approved impervious material shall be fitted under slop hoppers and water closets, and under baths, wash troughs and other plumbing fixtures.

*[By-law 28.8.1 amended in Gazette 29 December 1995 pp.6324-5.]*

28.8.2 Safes under Fixtures

- (a) The safe under a fixture shall discharge in some conspicuous place.
- (b) Where a water closet is on the ground floor of a house or building, where in the opinion of the Inspector, there is no likelihood of damage being caused by leakage or blockage, this by-law shall not apply.

28.8.3 Safe Overflow

Unless otherwise permitted, a safe shall be drained by a separate 50 mm diameter pipe provided at the inlet with a brass grating and at the outlet into the open air with a flap valve of brass or other approved metal and shall not connect with any waste pipe, soil pipe, property sewer or sewer.

*[By-law 28.8.3 amended in Gazette 24 December 1982 p.4929.]*

28.8.4 Cistern Overflows

- (a) A cistern supplied with water shall have an overflow pipe of adequate size discharging in such a position that it will not cause damage and act as a warning pipe.
- (b) On ground floors where cisterns are fixed over impervious floors graded to drain outside the room, the overflow may discharge on to such floors provided no damage is likely to arise therefrom.

28.8.5 Discharges from Safe Overflows

- (a) Overflows may discharge into the open air above ground level only when the discharge, in the opinion of the Inspector, will not cause any inconvenience or nuisance.
- (b) In all other cases the pipes shall be brought nearly to the ground surface, or be arranged to discharge where they will not prove a source of annoyance or inconvenience.

**bl. 28.9**

---

28.8.6 Existing Floors Under Fixtures

Where necessary in the opinion of the Corporation, the existing floor under a fixture shall, at the owners cost, be regraded, and a proper discharge pipe with flap valve fixed.

*[By-law 28.8.6 amended in Gazette 29 December 1995 pp.6324-5.]*

28.8.7 Existing Fixtures and Fittings, etc.

Existing fixtures, fitting and apparatus not in accordance with these by-laws and which in the opinion of the Corporation are unsatisfactory shall be removed or replaced by approved fittings at the cost of the owner.

*[By-law 28.8.7 amended in Gazette 29 December 1995 pp.6324-5.]*

**28.9 Plumbing general**

28.9.1 Waste Pipes

Separate waste pipes shall be provided for each of the following classes of polluted water, namely: —

- (a) Dirty water from baths, sinks, lavatory basins, and wash troughs and other waters containing a small proportion of soap or dirt; and
- (b) Greasy water from kitchens and scullery sinks or other fixtures, in such cases where grease traps are ordered or required.

28.9.2 Soil Pipes

Except as provided in by-law 28.9.3, soil pipes shall be provided for soil water from closets and other waters containing faecal matter and for urinal waters from slop hoppers and urinals, and where directed, for discharges from operating theatres and mortuaries.

*[By-law 28.9.2 amended in Gazette 24 December 1982 p.4929.]*



28.9.3 Combined Pipe System

28.9.3.1 The combined pipe system for plumbing installations may be used subject to the following conditions:

- (a) An interceptor or boundary trap shall be provided in the property sewer in accordance with by-law 25.11 of these by-laws;
- (b) Fixture traps shall be vented as required by these by-laws;
- (c) In order to prevent fouling of traps as much as possible by the discharge from water closets, slop hoppers and urinals, in the event of a blockage in the combined waste pipe — the waste pipe from baths and shower compartments or other fixtures, as determined, shall be branched into the combined waste stack; and
- (d) Such other conditions as may be imposed by the Corporation.

28.9.3.2 In by-law 28.9.3.1 —

**“combined waste pipe”** means any pipe which receives the discharges from both soil and waste fixtures and conveys those discharges to the property sewer.

*[By-law 28.9.3 amended in Gazette 24 December 1982 p.4929; 29 December 1995 pp.6324-5; 25 August 1998 p.4735.]*

28.9.4 Connections to Property Sewer

- (a) Waste pipes shall discharge under the grating and above the water seal of a yard gully or disconnecter trap.
- (b) Soil pipes, including those for urinals and slop hoppers shall be connected directly to a property sewer.

*[By-law 28.9.4 amended in Gazette 24 December 1982 p.4929.]*

*[28.9.5. Repealed in Gazette 28 June 1985 p.2351.]*

**bl. 28.9**

---

28.9.6 Sheet Metal Bends and Offsets

All sheet metal bends and offsets for flush and vent pipes, shall be bent or pressed. Mitred elbows shall not be used.

28.9.7 Painting

Except by permission of the Inspector, painting shall not be done on any part of the plumbing installation until after the work has been inspected and approved by the Inspector.

28.9.8 Inserting Junctions

- (a) Where it becomes necessary to insert a junction in an existing line of property sewer, a suitable length of property sewer shall be removed, and the junction, with an inspection opening on either side, dropped back into position, and the line tested in the usual manner.
- (b) Junctions in existing metal pipes shall not be made unless an approved closure pipe is used.

*[By-law 28.9.8 amended in Gazette 24 December 1982 p.4929.]*

28.9.9 Outlet Fittings to Fixtures

- (a) Subject to (c), where baths, sinks, basins, troughs and similar fixtures are constructed of cast iron, plate iron, ceramic ware or concrete, the connection between such fixtures and outlet fittings shall be made with locknuts.
- (b) The outlet fitting shall be connected to the waste pipe by means of a union.
- (c) When approved fixtures are made of sheet metal lighter than 20 gauge soldered connections may be used in lieu of locknuts.

28.9.10 Waste Pipes to Troughs

Connections of waste pipes to washtroughs shall be made as provided hereunder: —

- (a) Sheet metal troughs shall be connected to the waste pipe in compliance with by-law 28.9.9.
- (b) Where wrought iron or other screwed pipes are used the plug shall be connected to the trough by means of a locknut in lieu of flange.

28.9.11 Foot Baths

Approved foot baths shall have not less than 50 mm waste pipe trapped and vented similarly to wash troughs and baths and the dimensions of such foot baths shall be approved by the Corporation.

*[By-law 28.9.11 amended in Gazette 29 December 1995 pp.6324-5.]*

28.9.12 Vents Adjoining High Buildings

- (a) Where a building is erected next to an existing building of less elevation, and any door, window or other opening of the new building is located within 9 metres of a vent stack on the existing building, the owner of such new building shall defray the cost of such alterations to the vents of the existing building as necessary to conform with by-law 28.3.7.
- (b) Upon the receipt of money, or security therefor sufficient for the purpose, from the owner of the new building, the owner of the existing building shall make the necessary alterations, or shall permit at the request of the owner of the new building the making of such alterations, by the owner of such new building.

**bl. 28.9**

---

28.9.13 Down Venting

In special cases which must be approved by the Senior Inspector, vent pipes may be installed on the “down venting” principle. That is, the vent pipe from the fixture trap may be taken below level of the fixture and graded under the floor to an external wall or into the pipe duct and then carried up in accordance with the requirement of by-law 22.2. An approved accessible fitting shall be provided at the lowest point of such vent for the purpose of draining off any water or condensation collected therein.

28.9.14 Lead Pipes

Joints in lead pipe shall be plumber’s wiped joints.

28.9.15 Galvanized Steel Tubing to Lead Pipe

Joints between galvanized steel tubing and lead pipes shall be made by means of brass unions screwed to iron and wiped to lead.

28.9.16 Lead Pipe to Cast Iron Pipe

The connection of lead pipes or traps to cast iron pipes shall be made by means of brass sleeve; brass sleeve shall be lined with and connected to the lead pipe or trap by means of a wiped joint and connected to the cast iron by inserting the sleeve in socket thereof and making the joint in the same way as in cast iron pipe.

28.9.17 Sheet Iron Pipe to Wrought Iron Pipe

Galvanized sheet iron pipes shall be connected to wrought iron pipes by means of brass unions or thimbles soldered to the sheet iron and screwed to the wrought iron.

28.9.18 Use of Concrete

Concrete shall be used: —

- (a) For gully basins as specified in by-laws 18.13.3 and 28.3.3;
- (b) Around the top of educt vent and induct vent pipe sockets;
- (c) Around interceptor trap covers and tops of disconnector or other shafts;
- (d) Under and around bends rising vertically off oblique branches and under bases of all drainage traps;
- (e) Around property sewers which are liable to be affected by tree roots;
- (f) For property sewers under buildings as provided in by-law 25.1;
- (g) Around property sewers having insufficient cover as provided for in by-law 25.6; and
- (h) For floors under plumbing fixtures, where specified by the Inspector.

*[By-law 28.9.18 amended in Gazette 24 December 1982 p.4929.]*

28.9.19 Maintenance and Defective Work

- 28.9.19.1 (a) Where work is done other than in accordance with these by-laws or, in the opinion of the Corporation is defective, then, upon receiving notice in writing from the Corporation, the owner or occupier, or, in the case of common property sewerage, the owners or occupiers, of the property in which the work was done shall make good the defects as required, and within the time fixed, by the Corporation and to the satisfaction of the Inspector.

**bl. 28.9**

---

- (b) An owner or occupier who fails to comply with the terms of the notice of the Corporation, shall have committed an offence.
- (c) If an owner or occupier fails to comply with the notice of the Corporation, the board may make good the defects, and recover the cost incurred by it as a debt due to it by the owner or occupier.
- (d) This by-law does not apply to work that may be the subject of a notice under by-law 30.9.4C.1.

*[By-law 28.9.19.1 amended in Gazette 24 December 1982 p.4929; 22 December 1989 p.4636; 29 December 1995 pp.6324-5.]*

*[28.9.19.2. Repealed in Gazette 24 December 1982 p.4925.]*

*[29. Repealed in Gazette 18 June 1982 p.2023.]*

## **30.0 Licences and permits**

### **30.1 Persons who may carry out water supply plumbing**

*[By-law 30.1 inserted in Gazette 4 February 1997 p.713.]*

30.1.1 A person shall not carry out water supply plumbing unless that person —

- (a) is the holder of a water supply and sanitary plumber's licence under by-law 30.4;
- (b) is the holder of a water supply plumber's licence under by-law 30.4; or
- (c) is authorized under by-law 30.13 to work under the direction and supervision of a person holding a licence referred to in paragraph (a) or (b).

*[By-law 30.1.1 inserted in Gazette 4 February 1997 p.714.]*

30.1.2 Nothing in by-law 30.1.1 prohibits a person who is not a person described in paragraph (a), (b) or (c) of that by-law from carrying out work in connection with the installation of a water service by the Corporation.

*[By-law 30.1.2 inserted in Gazette 4 February 1997 p.714.]*

### **30.2 Persons who may carry out sanitary plumbing**

A person shall not carry out sanitary plumbing unless that person —

- (a) is the holder of a water supply and sanitary plumber's licence under by-law 30.4; or
- (b) is authorized under by-law 30.13 to work under the direction and supervision of a person holding a water supply and sanitary plumber's licence under by-law 30.4.

*[By-law 30.2 inserted in Gazette 4 February 1997 p.714.]*

**bl. 30.2A**

---

**30.2A Persons who may carry out drainage plumbing**

A person shall not carry out drainage plumbing unless that person —

- (a) is the holder of a water supply and sanitary plumber's licence under by-law 30.4;
- (b) is the holder of a drainage plumber's licence under by-law 30.4; or
- (c) is working under the direction and supervision of a person holding a licence referred to in paragraphs (a) and (b).

*[By-law 30.2A inserted in Gazette 4 February 1997 p.714.]*

**30.3 Penalties for doing work without a water supply or sanitary plumber's licence**

Any person who contravenes by-law 30.1, 30.2 or 30.2A commits an offence and is liable to a penalty of \$2 000.

*[By-law 30.3 amended in Gazette 14 October 1988 p.4174; 4 February 1997 p.714.]*

**30.4 Description and scope of licences**

*[By-law 30.4 inserted in Gazette 4 February 1997 p.715.]*

30.4.1 The Corporation may grant a water supply and sanitary plumber's licence, a water supply plumber's licence or a drainage plumber's licence on condition that —

- (a) the requirements set out in by-law 30.10, 30.11 or 30.11A, as the case requires, have been met;
- (b) the fee prescribed in item 4(a) of Schedule C has been paid; and
- (c) the Corporation is satisfied that the applicant for the licence —
  - (i) is a fit and proper person to hold a licence; and



(ii) is more than 21 years of age.

*[By-law 30.4.1 inserted in Gazette 4 February 1997 p.715;  
amended in Gazette 27 June 1997 p.3217.]*

30.4.2 The Corporation may issue a licence under by-law 30.4.1 subject to any special conditions that it considers desirable.  
*[By-law 30.4.2 inserted in Gazette 4 February 1997 p.715.]*

30.4.3 The holder of a water supply and sanitary plumber's licence may carry out work within the Metropolitan Water, Sewerage and Drainage Area, and, subject to by-laws 30.4.4 and 30.4.5, only plumbers holding such licences carry out or cause to be carried out water supply plumbing, sanitary plumbing or drainage plumbing within areas open for sewerage house connections.

*[By-law 30.4.3 inserted in Gazette 4 February 1997 p.715.]*

30.4.4 The holder of a drainage plumber's licence may carry out drainage plumbing within the Metropolitan Water, Sewerage and Drainage Area and may carry out or cause to be carried out drainage plumbing within areas open for sewerage house connections.

*[By-law 30.4.4 inserted in Gazette 4 February 1997 p.715.]*

*[30.4.5, 30.4.6. Repealed in Gazette 4 February 1997 p.715.]*

### **30.5 Conditions of licence**

30.5.1 The holder of a licence from the Corporation: —

- (a) shall execute such works in accordance with the provisions of the Act and of these by-laws, and of any special directions or orders given or issued by the Corporation;
- (b) shall execute such works in a thorough and tradesman-like manner to the satisfaction of the Corporation and as expeditiously as practicable;

**bl. 30.6**

---

- (c) shall on actual sewerage plumbing work, but not including property sewers, employ only such certificated operatives as provided in by-law 30.13;
- (d) shall obtain permission from the person or authorities concerned when necessary for the execution of such works on, over, or through any private property, or any streets, roads, parks, reserves, or other public places or properties;
- (e) shall pay fees demanded by any Municipality or other local authority for opening any street, road, or thoroughfare, or otherwise in connection with such work;
- (f) shall restore any part of any street, road, or thoroughfare interfered with by such work to the satisfaction of the local authority having control thereof, upon the completion of such work;
- (g) shall restore any other property interfered with by such work to the satisfaction of the Corporation's Inspector; and
- (h) shall, in the execution of such work, take such proper and necessary precautions that no accident or damages or unnecessary inconvenience may be directly or indirectly occasioned thereby.

*[By-law 30.5.1 amended in Gazette 24 December 1982 p.4929; 29 December 1995 pp.6324-5 and 6326.]*

- 30.5.2 Without prejudice to other rights of the Corporation when, in the opinion of the Corporation, the holder of a licence granted by the Corporation has failed to comply with the conditions of the licence, the Corporation may suspend or cancel the licence.

*[By-law 30.5.2 amended in Gazette 29 December 1995 pp.6324-5.]*

**30.6 Licence fees**

- 30.6.1 The fee set out in item 4(a) of Schedule C is the fee payable for the issue of a plumber's licence per quarter of the year (or part thereof) for which the licence is issued.

*[By-law 30.6.1 inserted in Gazette 29 June 1990 p.3246; amended in Gazette 4 February 1997 p.715; 27 June 1997 p.3217.]*

- 30.6.2 The fee set out in item 4(b) of Schedule C is the fee payable for the renewal of a plumber's licence.

*[By-law 30.6.2 inserted in Gazette 29 June 1990 p.3246 (erratum in Gazette 6 July 1990 p.3318); amended in Gazette 14 February 1997 p.715; 27 June 1997 p.3217.]*

**30.7 Renewal of licences**

A plumber's licence shall be current only to 30 June next following the date of issue and may be renewed each year for a period of 12 months expiring on 30 June in the next succeeding year. The holder of a plumber's licence shall apply for a renewal thereof and pay the necessary fee prior to the expiration of the period for which his existing licence is current.

*[By-law 30.7 amended in Gazette 29 December 1995 pp.6324-5; 4 February 1997 p.715.]*

**30.8 List of licensed plumbers shall be published**

A list of licensed plumbers shall from time to time be published at the office of the Corporation.

*[By-law 30.8 amended in Gazette 29 December 1995 pp.6324-5; 4 February 1997 p.715.]*

**bl. 30.9**

---

**30.9 Notices, applications, permits, and inspection of works**

**30.9.1** Definitions

In by-laws 30.9.2 to 30.9.4F, unless the contrary intention appears —

**“book of forms”** means —

- (a) in relation to a notice or certificate, a book of approved forms of notice and certificate; and
- (b) in relation to a multi-entry plumbing certificate, a book of approved forms of multi-entry plumbing certificate,

as referred to in by-law 30.9.4D.1;

**“certificate”** means a certificate of completion and compliance under by-law 30.9.3.1;

**“emergency work”** means work that must be carried out immediately by a licensed plumber to prevent —

- (a) the waste, undue consumption, misuse or contamination of water supplied by the Corporation’s water supply system;
- (b) the entry into the Corporation’s sewerage system of any substance or matter that is likely to hinder or prevent the proper functioning of that system; or
- (c) the escape from the Corporation’s sewerage system of foul air or offensive matter;

**“multi-entry plumbing certificate”** means a certificate under by-law 30.9.4B;

**“multi-entry work”** means —

- (a) emergency work;
- (b) maintenance, repair or replacement work of a kind described in each book of forms of multi-entry plumbing certificate; and

- (c) work to connect garden reticulation systems to the Corporation's works of the kind described in each book of forms referred to in paragraph (b);

**"notice"** means a notice of intention to commence work under by-law 30.9.2;

**"notified work"** means work described in a notice;

**"working day"** means a day of the week other than a Saturday, Sunday, public holiday or public service holiday.

*[By-law 30.9.1 inserted in Gazette 22 December 1989 p.4636; amended in Gazette 21 September 1990 p.4952; 29 December 1995 p.6327.]*

### 30.9.2 Notification of work

- 30.9.2.1 Subject to by-laws 30.9.4B and 30.9.4F, a licensed plumber shall not carry out, or cause to be carried out, any work in connection with water supply or sewerage which is connected, or is intended to connect to the Corporation's works unless the licensed plumber has lodged with the Corporation a notice of intention to commence work not less than 2 working days before commencement of the work.

Penalty: \$500.

*[By-law 30.9.2.1 inserted in Gazette 22 December 1989 p.4636; amended in Gazette 21 September 1990 p.4952; 29 December 1995 pp.6326-7 and 6327.]*

- 30.9.2.2 A notice of intention to commence work shall be in a form approved by the Corporation, legibly completed and signed by the licensed plumber who is to carry out the work.

*[By-law 30.9.2.2 inserted in Gazette 22 December 1989 p.4636; amended in Gazette 29 December 1995 pp.6326-7.]*

- 30.9.2.3 The may Corporation refuse to accept for lodgement a notice that does not comply with by-law 30.9.2.2.

*[By-law 30.9.2.3 inserted in Gazette 22 December 1989 p.4636; amended in Gazette 29 December 1995 pp.6326-7.]*

**bl. 30.9**

---

30.9.2.4 A licensed plumber who lodges a notice —

- (a) is responsible for the performance of the notified work whether the work is carried out by that licensed plumber or by another person under the direction and supervision of that licensed plumber; and
- (b) shall ensure that the notified work is carried out in accordance with these by-laws.

Penalty for contravention of paragraph (b): \$2 000.

*[By-law 30.9.2.4 inserted in Gazette 22 December 1989 p.4636; amended in Gazette 21 September 1990 p.4952.]*

30.9.3 Certification of work

30.9.3.1 Within 7 working days of completing notified work the licensed plumber shall lodge with the Corporation —

- (a) a certificate of completion and compliance in respect of the notified work; and
- (b) in the case of a property sewer installation, a diagram or diagrams of the completed work in such form or forms as the Corporation may require.

Penalty: \$1 000.

*[By-law 30.9.3.1 inserted in Gazette 22 December 1989 p.4636; amended in Gazette 29 December 1995 pp.6326-7.]*

30.9.3.1A Where the Corporation provides plan sheets for the preparation of diagrams under by-law 30.9.3.1(b), the appropriate fee set out in item 9 of Schedule C is payable in respect of the provision of those sheets.

*[By-law 30.9.3.1A inserted in Gazette 29 June 1990 p.3246; amended in Gazette 29 December 1995 pp.6326-7; 27 June 1997 p.3217.]*

30.9.3.2 A certificate of completion and compliance shall be in a form approved by the Corporation, legibly completed and signed by the licensed plumber responsible for the notified work.

*[By-law 30.9.3.2 inserted in Gazette 22 December 1989 p.4636; amended in Gazette 29 December 1995 pp.6326-7.]*

30.9.3.3 The licensed plumber shall give a copy of a certificate lodged under by-law 30.9.3.1 to the owner or occupier of the premises on which the notified work was carried out within 7 working days of completing that work.

Penalty: \$500.

*[By-law 30.9.3.3 inserted in Gazette 22 December 1989 p.4637; amended in Gazette 29 June 1990 p.3245.]*

30.9.4 Alteration, withdrawal or cancellation of notice

30.9.4.1 If after the commencement of notified work a licensed plumber wishes to alter or withdraw the notice lodged in respect of that work, the licensed plumber shall —

(a) Lodge with the Corporation —

(i) the certificate that corresponds to the notice, duly completed in accordance with the instructions set out in the book of forms; and

(ii) in the case of alteration, a fresh notice complying with by-law 30.9.2.2;

and

(b) give a copy of the certificate that corresponds to the notice to the owner or occupier of the premises concerned.

*[By-law 30.9.4.1 inserted in Gazette 22 December 1989 p.4637; amended in Gazette 29 December 1995 pp.6326-7.]*

**bl. 30.9**

---

30.9.4.2 Where notified work is not to be commenced the licensed plumber shall cancel the notice in respect of that work by lodging with the Corporation the certificate that corresponds to the notice, duly completed in accordance with the instructions set out in the book of forms.

*[By-law 30.9.4.2 inserted in Gazette 22 December 1989 p.4637; amended in Gazette 29 December 1995 pp.6326-7.]*

30.9.4.3 A licensed plumber who fails to comply with any of the requirements of by-law 30.9.4.1 or 30.9.4.2 in relation to the alteration, withdrawal or cancellation of a notice commits an offence.

Penalty: \$500.

*[By-law 30.9.4.3 inserted in Gazette 22 December 1989 pp.4636-7.]*

30.9.4A Work taken over by another licensed plumber

30.9.4A.1 Where notified work has been commenced but a licensed plumber other than the licensed plumber named in the notice (in this by-law and by-law 30.9.4A.2 called “**the first licensed plumber**”) is to take over and complete the work, the first licensed plumber shall withdraw the notice in the manner set out in by-law 30.9.4.1(a)(i) and (b).

*[By-law 30.9.4A.1 inserted in Gazette 22 December 1989 p.4637.]*

30.9.4A.2 The licensed plumber taking over the work referred to in by-law 30.9.4A.1 shall —

- (a) lodge with the Corporation a fresh notice advising the Corporation of the change of licensed plumber;
- (b) provide the Corporation with written confirmation of the change of licensed plumber from the owner or occupier of the premises on which the work is being carried out; and



- (c) within 7 working days of completing the work, lodge a certificate in respect of the work carried out, including any work carried out but not certified by the first licensed plumber.

*[By-law 30.9.4A.2 inserted in Gazette 22 December 1989 p.4637.]*

30.9.4A.3 A licensed plumber who fails to comply with a requirement of by-law 30.9.4A.1 or 30.9.4A.2 commits an offence.

Penalty: \$500.

*[By-law 30.9.4A.3 inserted in Gazette 22 December 1989 p.4637; amended in Gazette 29 December 1995 pp.6326-7.]*

30.9.4B Multi-entry plumbing certificates

30.9.4B.1 Notwithstanding by-law 30.9.2, a licensed plumber is not required to lodge a notice before commencing multi-entry work but upon completion of such work shall —

- (a) enter the details of the work in a multi-entry plumbing certificate; and
- (b) lodge with the Corporation —
  - (i) the multi-entry plumbing certificate; and
  - (ii) in the case of any property sewer installation, a diagram or diagrams of the completed work in such form or forms as the Corporation may require,

within one month of the date of completion of the work first described in that certificate.

Penalty: \$500.

*[By-law 30.9.4B.1 inserted in Gazette 22 December 1989 p.4637; amended in Gazette 29 December 1995 pp.6326-7.]*

**bl. 30.9**

---

30.9.4B.2 A multi-entry plumbing certificate shall be in a form approved by the Corporation, legibly completed and signed by the licensed plumber responsible for the work described in that certificate.

*[By-law 30.9.4B.2 inserted in Gazette 22 December 1989 p.4637; amended in Gazette 29 December 1995 pp.6326-7.]*

30.9.4C Directions by Corporation as to work

30.9.4C.1 Where the Corporation is of the opinion that a licensed plumber —

- (a) has not commenced notified work within 12 months of the date of lodgement of a notice and has not withdrawn or cancelled that notice under by-law 30.9.4;
- (b) has commenced notified work or multi-entry work but has failed to complete that work within a reasonable time; or
- (c) has carried out notified work or multi-entry work that is not in accordance with these by-laws,

the Corporation may, by notice in writing given to the licensed plumber or the owner or occupier of the premises concerned, direct the person so notified to ensure that the work is commenced, completed or otherwise carried out within such time and subject to such conditions as are specified in the notice.

*[By-law 30.9.4C.1 inserted in Gazette 22 December 1989 p.4637; amended in Gazette 29 December 1995 pp.6326-7.]*

30.9.4C.2 The Corporation may by further notice in writing vary or cancel a notice given under by-law 30.9.4C.1.

*[By-law 30.9.4C.2 inserted in Gazette 22 December 1989 p.4637; amended in Gazette 29 December 1995 pp.6326-7.]*

30.9.4C.3 A person who fails to comply with a direction contained in a notice given under by-law 30.9.4C.1, or in such a notice as varied under by-law 30.9.4C.2, commits an offence.

Penalty: \$1 000 and if the offence is a continuing one a further fine of \$50 for every day or part of a day during which the offence continues after notice of the offence has been given by or on behalf of the Corporation to the offender.

*[By-law 30.9.4C.3 inserted in Gazette 22 December 1989 pp.4637-8; amended in Gazette 29 December 1995 p.6323.]*

30.9.4C.4 Where a notice under by-law 30.9.4C.1, or such a notice as varied under by-law 30.9.4C.2, is not complied with, the Corporation may refuse permission for connection of the work to the Corporation's works.

*[By-law 30.9.4C.4 inserted in Gazette 22 December 1989 p.4638; amended in Gazette 29 December 1995 pp.6326-7.]*

30.9.4C.5 A person convicted of an offence under by-law 30.9.4C.3 shall, in addition to any penalty incurred under that by-law, pay any expense, loss or damage incurred by the Corporation in consequence of the offence.

*[By-law 30.9.4C.5 inserted in Gazette 22 December 1989 p.4638; amended in Gazette 29 December 1995 pp.6326-7.]*

30.9.4C.6 The appropriate fee set out in item 7 of Schedule C is payable by the person to whom a notice is given under by-law 30.9.4C.1 for the inspection of work commenced, completed or otherwise carried out in accordance with that notice.

*[By-law 30.9.4C.6 inserted in Gazette 22 December 1989 p.4638; amended in Gazette 27 June 1997 p.3217.]*

30.9.4D Forms

30.9.4D.1 A licensed plumber may obtain a book of the approved forms of notice and certificate, or multi-entry plumbing certificate from the Corporation on payment of the appropriate fee set out in item 8 of Schedule C.

*[By-law 30.9.4D.1 inserted in Gazette 22 December 1989 p.4638; amended in Gazette 29 December 1995 pp.6326-7; 27 June 1997 p.3217.]*

**bl. 30.9**

---

30.9.4D.2 A licensed plumber shall comply with any instructions contained in a book of forms in relation to the completion and place of lodgement of a notice, certificate or multi-entry plumbing certificate.

Penalty: \$100.

*[By-law 30.9.4D.2 inserted in Gazette 22 December 1989 p.4638.]*

30.9.4E False or misleading statements

A licensed plumber in completing a notice certificate or multi-entry plumbing certificate shall not make a statement or give any information which the licensed plumber knows is false or misleading in a material particular.

Penalty: \$1 000.

*[By-law 30.9.4E inserted in Gazette 22 December 1989 p.4638.]*

30.9.4F Exemption

30.9.4F.1 The Corporation may, by notice in writing given, as far as is practicable, to every licensed plumber, exempt a type or types of work specified in the notice from the notification and certification requirements of by-laws 30.9.2 and 30.9.3.

*[By-law 30.9.4F.1 inserted in Gazette 22 December 1989 p.4638; amended in Gazette 29 December 1995 pp.6326-7.]*

30.9.4F.2 The Corporation may by further notice in writing vary or cancel a notice given under by-law 30.9.4F.1.

*[By-law 30.9.4F.2 inserted in Gazette 22 December 1989 p.4638; amended in Gazette 29 December 1995 pp.6326-7.]*

30.9.5 Corporation may require certain tests

30.9.5.1 The Corporation may, by notice in writing given, as far as is practicable to every licensed plumber, require work carried out by, or under the direction and supervision of, a licensed plumber

to be tested by the application of the water test in accordance with by-law 27.8.2, the smoke test in accordance with by-law 27.8.3, or any other test that the Corporation considers necessary and specifies in the notice.

*[By-law 30.9.5.1 inserted in Gazette 21 September 1990 p.4952; amended in Gazette 29 December 1995 pp.6326-7.]*

- 30.9.5.2 The equipment, material, power and labour necessary for a test required under by-law 30.9.5.1 shall be furnished by the licensed plumber responsible for the work to be tested.

*[By-law 30.9.5.2 inserted in Gazette 21 September 1990 p.4952.]*

30.9.6 Testing and inspection of Work

- 30.9.6.1 Water pipes, property sewers, or apparatus in connection with water supply or property sewers, shall not be used until the work has been tested by the licensed plumber responsible for the work, or by a person under the direction and supervision of that licensed plumber, to ensure compliance with these by-laws.

*[By-law 30.9.6.1 inserted in Gazette 21 September 1990 p.4952.]*

- 30.9.6.2 An inspector may inspect or test work carried out by, or under the direction and supervision of, a licensed plumber, and for this purpose a licensed plumber shall —

- (a) immediately report to the Corporation work that is ready for inspection or testing; and
- (b) ensure that every facility is made available to an inspector for conducting an inspection or test of the work.

*[By-law 30.9.6.2 inserted in Gazette 22 September 1990 p.4952; amended in Gazette 29 December 1995 pp.6326-7.]*

**[30.9.7, 30.9.8. Repealed in Gazette 22 December 1989 p.4638.]**

**bl. 30.10**

---

30.9.9 Attention is drawn to section 102 of the *Metropolitan Water Authority Act 1982* relating to connection to main drains.

*[By-law 30.9.9 inserted in Gazette 24 December 1982 p.4925.]*

30.9.10 An application for approval to connect to a main drain shall be in writing in a form approved by the Corporation and shall be accompanied by one copy of all relevant plans.

*[By-law 30.9.10 inserted in Gazette 24 December 1982 p.4925; amended in Gazette 29 December 1995 pp.6326-7.]*

30.9.11 Connection to main drain

A person shall not execute work to connect to a main drain without first obtaining approval from the Corporation.

Penalty: \$500.

*[By-law 30.9.11 inserted in Gazette 22 December 1989 p.4638; amended in Gazette 29 December 1995 pp.6326-7.]*

**30.10 Water supply plumbers**

*[By-law 30.10 inserted in Gazette 4 February 1997 p.716.]*

30.10.1 An applicant for a water supply plumber's licence shall provide the Corporation with a certificate issued by an approved examining body to the effect that the applicant has knowledge and competence in the following areas —

- (a) water supply plumbing;
- (b) the materials and apparatus related to water supply plumbing;
- (c) the proper pipes and fittings for hot water installations; and
- (d) these by-laws and the by-laws of local authorities in the Metropolitan Water Supply, Sewerage and Drainage Area as they relate to water supply plumbing.

*[By-law 30.10.1 inserted in Gazette 4 February 1997 p.716.]*

30.10.2 The applicant shall satisfy the Corporation as to the applicant's practical ability in relation to water supply plumbing.

*[By-law 30.10.2 inserted in Gazette 4 February 1997 p.716.]*

**30.11 Water supply and sanitary plumbers**

*[By-law 30.11 inserted in Gazette 4 February 1997 p.716.]*

30.11.1 An applicant for a water supply and sanitary plumber's licence shall provide the Corporation with a certificate issued by an approved examining body to the effect that the applicant has knowledge and competence in the following areas —

- (a) water supply plumbing, sanitary plumbing and drainage plumbing;
- (b) the materials and apparatus related to water supply plumbing, sanitary plumbing and drainage plumbing;
- (c) the proper pipes and fittings for hot water installations; and
- (d) these by-laws and the by-laws of local authorities in the Metropolitan Water Supply, Sewerage and Drainage Area as they relate to water supply plumbing, sanitary plumbing and drainage plumbing.

*[By-law 30.11.1 inserted in Gazette 4 February 1997 p.716.]*

30.11.2 The applicant shall satisfy the Corporation —

- (a) as to the applicant's practical ability in relation to water supply plumbing, sanitary plumbing and drainage plumbing; and
- (b) that the applicant has served not less than 5 years at that trade.

*[By-law 30.11.2 inserted in Gazette 4 February 1997 p.716.]*

**bl. 30.11A**

---

**30.11A Drainage plumbers**

*[By-law 30.11A inserted in Gazette 4 February 1997 p.716.]*

30.11A.1 An applicant for a drainage plumber's licence shall provide the Corporation with a certificate issued by an approved examining body to the effect that the applicant has knowledge and competence in the following areas —

- (a) drainage plumbing;
- (b) the materials and apparatus related to drainage plumbing; and
- (c) these by-laws and the by-laws of local authorities in the Metropolitan Water Supply, Sewerage and Drainage Area as they relate to drainage plumbing.

*[By-law 30.11A.1 inserted in Gazette 4 February 1997 p.716.]*

30.11A.2 The applicant shall satisfy the Corporation as to the applicant's practical ability in relation to drainage plumbing.

*[By-law 30.11A.2 inserted in Gazette 4 February 1997 p.717.]*

**30.12 Applicants holding licences from overseas authorities**

An applicant for a plumber's licence who holds a licence issued by an overseas authority may be exempted from such of the requirements of by-laws 30.10, 30.11 and 30.11A as the Corporation thinks fit.

*[By-law 30.12 inserted in Gazette 4 February 1997 p.717.]*

**30.13 Persons authorized to carry out plumbing work under direction and supervision**

*[By-law 30.13 inserted in Gazette 4 February 1997 p.717.]*

30.13.1 The following persons are authorized for the purposes of by-laws 30.1.1(c) and 30.2(b) —

- (a) a person who has successfully completed an apprenticeship in the plumbing trade; and



- (b) a person registered under the *Industrial Training Act 1975* as an apprentice in the plumbing trade.

*[By-law 30.13.1 inserted in Gazette 4 February 1997 p.717.]*

30.13.2 The Corporation may authorize a person for the purposes of by-laws 30.1.1(c) or 30.2(b) if the person —

- (a) provides the Corporation with a certificate issued by an approved examining body to the effect that the person has a sufficient level of knowledge and competence to be so authorized; or
- (b) satisfies the Corporation that the person has a sufficient level of knowledge and competence to be so authorized.

*[By-law 30.13.2 inserted in Gazette 4 February 1997 p.717.]*

30.13.3 The Corporation may, where it considers necessary, authorize a person under by-law 30.13.2(b) —

- (a) to work only under the immediate supervision of a person holding a water supply plumber's licence or a water supply and sanitary plumber's licence under by-law 30.4, as the case requires; and
- (b) for no longer than 12 months.

*[By-law 30.13.3 inserted in Gazette 4 February 1997 p.717.]*

**30.14 Registration of certificates of persons provided for in by-law 30.13**

A register shall be kept at the Corporation's Head Office of all persons authorized under by-laws 30.12.1 and 30.13.2.

*[By-law 30.14 amended in Gazette 29 December 1995 p.6326; 4 February 1997 p.717.]*

*[30.15. Repealed in Gazette 22 December 1989 p.4638.]*

**bl. 30.16**

---

**30.16 Damage to pipes shall be reported**

Damage caused by licensed plumbers or their employees to water, sewer, gas, or other pipes shall be reported forthwith by the plumber to the authority concerned, and immediate steps shall be taken to have repairs effected, and the cost of same shall be defrayed by such plumber.

*[By-law 30.16 inserted in Gazette 4 February 1997 p.717.]*

**30.16A Plumbers to report certain matters**

**30.16A.1** A licensed water supply and sanitary plumber shall immediately report to the Corporation anything found by, or brought to the attention of, the plumber, in the course of carrying out plumbing work, that is likely to result in —

- (a) the contamination of water supplied by the Corporation's water supply system; or
- (b) the entry into the Corporation's sewerage system of any substance or matter likely to hinder or prevent the proper functioning of that system.

Penalty: \$2 000.

*[By-law 30.16A.1 inserted in Gazette 22 December 1989 p.4638; amended in Gazette 29 December 1995 pp.6326-7 and 6327.]*

**30.16A.2** A licensed water supply plumber shall immediately report to the Corporation anything found by, or brought to the attention of, the plumber, in the course of carrying out plumbing work, that is likely to result in the contamination of water supplied by the Corporation's water supply system.

Penalty: \$2 000.

*[By-law 30.16A.2 inserted in Gazette 22 December 1989 p.4638; amended in Gazette 29 December 1995 pp.6326-7 and 6327.]*

30.16A.3 A person holding a drainage plumber's licence under by-law 30.4 shall immediately report to the Corporation anything found by, or brought to the attention of, the plumber in the course of carrying out plumbing work, that is likely to result in the entry into the Corporation's sewerage system of any substance or matter likely to hinder or prevent the proper functioning of that system.

Penalty: \$2 000.

*[By-law 30.16A.3 inserted in Gazette 4 February 1997 pp.717-8.]*

**30.17 Statement to be signed**

Before any licence is issued, the person to whom the same is to be issued shall sign a statement that he accepts the licence subject to the conditions thereof and with these by-laws, and that he will comply therewith.

**30.18 Change of address shall be notified**

A licensed plumber shall, within 48 hours of any change in his address, give notice in writing thereof to the Corporation.

*[By-law 30.18 amended in Gazette 29 December 1995 pp.6324-5; 4 February 1997 p.718.]*

**30.19 Penalties for breaches of by-laws by plumbers**

30.19.1 A licensed plumber who refuses either by himself or by those employed by him to give information properly required by an officer of the Corporation shall be guilty of an offence and liable to a fine not exceeding \$200.00.

*[By-law 30.19.1 amended in Gazette 24 December 1982 p.4930; 29 December 1995 pp.6324-5; 4 February 1997 p.718.]*

**bl. 30.19**

---

30.19.2 A licensed plumber who commits a breach of these by-laws may be required by the Corporation to show cause why his licence should not be suspended or cancelled.

*[By-law 30.19.2 amended in Gazette 29 December 1995 pp.6324-5; 4 February 1997 p.718.]*

30.19.3 A plumber whose licence has been suspended shall not be relicensed as a licensed water supply and sanitary plumber or water supply plumber until the term of his suspension has expired, or the Corporation has directed the reinstatement of his licence.

*[By-law 30.19.3 amended in Gazette 29 December 1995 pp.6324-5; 4 February 1997 p.718.]*

## **31.0 Offences and penalties**

### **31.1 Gratuities prohibited**

Officers, workmen, or agents of the Corporation shall not solicit or receive any fee or gratuity whatever.

*[By-law 31.1 amended in Gazette 29 December 1995 pp.6324-5.]*

### **31.2 Junction or interference with pipes, sewers, or fittings**

No person shall make any connection or interfere with any pipe, sewer, or fitting of the Corporation or with any water pipes, sewer, or drain communicating therewith, at any other place than shall be approved by the Corporation, and the main shall be tapped only by the Corporation.

*[By-law 31.2 amended in Gazette 29 December 1995 pp.6323 and 6324-5.]*

### **31.3 Obstruction of sewers and main drains**

*[By-law 31.3 inserted in Gazette 24 December 1982 p.4925.]*

31.3.1 Attention is drawn to section 66 of the Act relating to construction, in, upon, over, under or in proximity to a sewer.

*[By-law 31.3.1 inserted in Gazette 24 December 1982 p.4925.]*

31.3.2 Attention is drawn to section 101 of the *Metropolitan Water Authority Act 1982* relating to construction upon, over, under or in proximity to a main drain.

*[By-law 31.3.2 inserted in Gazette 24 December 1982 p.4925.]*

*[31.3.3, 31.3.4. Repealed in Gazette 24 December 1982 p.4925.]*

### **31.4 Penalties**

31.4.1 A person committing a breach of any of the provisions of these by-laws, to which no specific penalty is attached shall be liable

**bl. 31.5**

---

on summary conviction to a penalty not exceeding \$200.00 and in addition may be ordered to pay any expense incurred by the Corporation or the Commission in consequence of such breach.

*[By-law 31.4.1 amended in Gazette 24 December 1982 p.4930; 29 December 1995 p.6326.]*

- 31.4.2 In the case of a continuing breach the offender shall be liable in addition to the fine and payment of expenses to a daily penalty not exceeding \$20.00 for each day the breach continues after notice thereof has been given by or on behalf of the Corporation or the Commission to the offender.

*[By-law 31.4.2 amended in Gazette 24 December 1982 p.4930; 29 December 1995 p.6326.]*

**31.5 Authority to enter premises**

- 31.5.1 An officer or other person authorized by the Corporation may at all reasonable times enter any property connected, or in process of being connected with the water mains or sewers, in order to examine whether the water pipes, drains, property sewers and other fittings in such property are in proper order, and any person refusing such admission or in any way hindering such officer or other person in the execution of his duty shall be guilty of an offence.

*[By-law 31.5.1 amended in Gazette 24 December 1982 p.4930; 29 December 1995 pp.6323-4.]*

- 31.5.2 An Inspector, or any assistant acting under the directions of an Inspector, or other authorized officer may, at his discretion, at any reasonable hour, with or without notice, enter any land, house, or premises for the purpose of ascertaining whether any act or thing is being done or permitted within such property in breach of these by-laws, and to remove, or cause to be removed, anything therein or thereon in breach of these by-laws, or to take such steps as he may deem necessary for carrying out these provisions.

- 31.5.3 The cost of such removal or such other necessary act shall be borne by the owner or occupier of the property upon which such breach shall occur.

**31.6 Period for compliance with notices**

Unless otherwise provided, the time which may elapse between the giving of a notice and the doing of a thing required to be done by any Inspector or other authorized officer shall be determined by the Corporation according to the nature of each case.

*[By-law 31.6 amended in Gazette 29 December 1995  
pp.6324-5.]*

**bl. 32.1**

---

**32.0 Miscellaneous**

**32.1 Standard drawings for fixtures and fittings**

32.1.1 Approved standard drawings of fixtures and fittings will be exhibited at the Corporation's office.

*[By-law 32.1.1 amended in Gazette 29 December 1995 p.6326.]*

32.1.2 Due consideration shall be given by the Corporation to the claims of any other fittings which may be presented for approval, and, if considered satisfactory, the same may be placed among and become one of the approved standard fittings.

*[By-law 32.1.2 amended in Gazette 29 December 1995 pp.6324-5.]*

32.1.3 The Corporation may, from time to time, amend, alter, or cancel any or all of the standard fittings or type drawings, and replace them by such other approved fittings or drawings.

*[By-law 32.1.3 amended in Gazette 29 December 1995 pp.6324-5.]*

*[32.2. Repealed in Gazette 29 June 1999 p.2785.]*

*[Schedule A deleted in Gazette 18 June 1982 p.2023.]*



**Schedule B**

(5.2.1.1)

**Form 1**

**WATER AND RIVERS COMMISSION  
APPLICATION FOR A WELL LICENCE**

(Under Section 57G of the *Metropolitan Water Supply, Sewerage, and Drainage Act 1909*<sup>1a</sup> as amended).

OWNER OF LAND	Name.....	
	Address.....	
	Telephone.....	Postcode .....
OCCUPIER (if same as Owner write "As above")	Name.....	
	Address.....	
	Telephone.....	Postcode .....
PROPERTY	Hse No.....	Lot No. .... Street .....
	Postal District.....	
	Town/City/Shire of.....	
CLASSIFICATION	Existing Well (or bore)	<input type="checkbox"/> (Place ✓ in relevant box)
	Sink a new Well (or bore)	<input type="checkbox"/> Month/year constructed..... /.....
	Alter or deepen a Well (or bore)	<input type="checkbox"/> Licence No. ....
	Change of licence conditions	<input type="checkbox"/> Licence No. ....
CONSTRUCTION	Proposed depth (if known) .....	m
	Method of construction (if known)	
	Self <input type="checkbox"/>	
	Contractor <input type="checkbox"/>	Name .....
	Other <input type="checkbox"/>	.....
	Proposed pump rate .....	litres/second

**Schedule B**

			OFFICE USE
	DOMESTIC GARDEN WATERING	<input type="checkbox"/>	
	HOUSEHOLD USE	<input type="checkbox"/>	
PURPOSE OF WELL OR BORE Indicate by a [tick] in the relevant box	STOCK WATERING — number of	<input type="checkbox"/>	
	horses .....		
	cattle .....		
	sheep .....		
	pigs — open run .....		
	penned .....		
	other .....		
	COMMERCIAL POULTRY	<input type="checkbox"/>	
	Number of birds .....		
	Roof sprinklers <input type="checkbox"/>		
Foggers <input type="checkbox"/>			
Information given should include that for adjacent lots where it is proposed water from the well will be shared with these lot owners	COMMERCIAL IRRIGATION	Area ha <input type="checkbox"/>	
	Vegetables .....		
	Lucerne .....		
	Other pasture .....		
	Nursery .....		
	Orchard .....		
	Other. ....		
PARK & RECREATION	<input type="checkbox"/>		
Area irrigated ..... ha			
.....			
.....			
INDUSTRIAL	<input type="checkbox"/>		
Specify intended purposes for water use giving annual quantities.			
.....			
.....			
.....			
OTHER	<input type="checkbox"/>		
.....			
.....			
.....			
.....			
.....			

**Schedule B**

ADJACENT PROPERTIES	If water from a well is to be shared with adjacent properties give details below.		
	Street Name	Hse. Number	Lot Number
	1. ....	.....	.....
	2. ....	.....	.....
	3. ....	.....	.....
	4. ....	.....	.....
	5. ....	.....	.....
	6. ....	.....	.....
<hr/>			
	Nature of agreements.....		
	.....		
	.....		
<hr/>			
	APPLICANTS SIGNATURE.....		
	ADDRESS (IF NOT OWNER.....		
	OR OCCUPIER).....		
	TELEPHONE.....		
	DATE.....		

**SITE PLAN.**

- Distances of existing and proposed wells from side boundaries of the property are to be shown in metres.
- Show the location of any existing or abandoned septic tanks, leach drains or soak wells and their distance from the proposed well.
- The *Health Act (Underground Water Supply) Regulations 1959* require wells to be not less than 30m from septic tanks, soak wells or leach drains.
- The Commission may require alterations to the location, plans and specification of any work proposed in this application before it issues a licence.

**Schedule B**

---

**Form 2**

*Water Agencies (Powers) Act 1984*  
**GROUNDWATER WELL LICENCE**

Issued under section 57G of the *Metropolitan Water Supply, Sewerage and Drainage Act 1901*<sup>1a</sup> as amended

---

Name  
and address  
of licensee

---

Description  
of land  
upon which  
wells are  
located

---

Location  
of wells

---

Things that  
may be  
done  
pursuant to  
this licence

---

Licence  
expiry

---

Purpose  
for which  
water may  
be used

---

This licence is subject to the following terms, limitations and conditions.

Given under my hand this ..... day of  
..... Authorized Officer

Form 3

(5.2.2.1)

WATER AND RIVERS COMMISSION  
WELL COMPLETION STATEMENT

LICENCE No.

[Empty box for LICENCE No.]

LICENSEE: Name.....  
 Address.....  
 Telephone.....Postcode .....

PROPERTY: Hse No.....Lot No. .... Street .....

Postal District.....  
 Town/City/Shire of.....

CONTRACTOR: Name.....  
 (if applicable) Address.....  
 .....Postcode .....

COMPLETION: Date Commenced.....Date Completed .....

How was the completed well left:

Capped	<input type="checkbox"/>	Equipment for use	<input type="checkbox"/>
Casing pulled	<input type="checkbox"/>	Abandoned	<input type="checkbox"/>
Left for water level observation	<input type="checkbox"/>	Other.....	

Motor power ..... kW/HP      Depth ..... m  
 Approx.

LOCATION PLAN: Draw a location plan of the well on the back of this Statement where indicated.

REMARKS:

Signature of Licensee.....Date .....

Note: The Contractor may complete this form but the accuracy of the information should be verified as far as possible by the licensee or his representative and forwarded to:

Chief Executive Officer  
Water and Rivers Commission  
Hyatt Centre, 87 Adelaide Terrace  
EAST PERTH WA 6004

**Schedule B**

---

**LOCATION PLAN OF WELL.**

Distances from side boundaries should be measured in metres.

Location of septic tanks, leach drains and soak wells should be shown in relation to the well.

**SUPPLEMENTARY INFORMATION**

To be completed only when requested.

PLANT USED: Rotary Drill Rig Sand or Sludge Pump  
 Cable Tool Drill Rig Other.....  
 Air Drill Rig

**STRATA DETAILS:**

Depth from surface		Description of Strata
From	To	
0 m		

eg. Fine sand, coarse sand, shelly sand, limestone, peat, clay, coffey rock, or other such description.

**WATER FOUND**

Strata	Description of Quality & Supply
..... m to ..... m	
..... m to ..... m	
..... m to ..... m	

REMARKS: .....

.....

.....

.....

.....

.....

.....

.....

.....

.....

SIGNATURE OF LICENSEE.....DATE .....

AS CONSTRUCTED DATA

SEE DIAGRAMS BELOW

1. DEPTH: A ..... metres
- B ..... metres
- C ..... metres
- D ..... metres
- E ..... metres to water
2. CASING: Diam ..... mm from ..... m to .....m
- ..... mm from ..... m to .....m
- Material: Steel/GWI/PVC
- Other.....
- is casing slotted? YES/NO If so give details in remarks.
- Well liners Number ..... mm Total well liner length .....m
3. SCREENS: Length ..... m diam ..... mm Aperture ..... mm
- Material of construction.....
- make.....

Schedule B

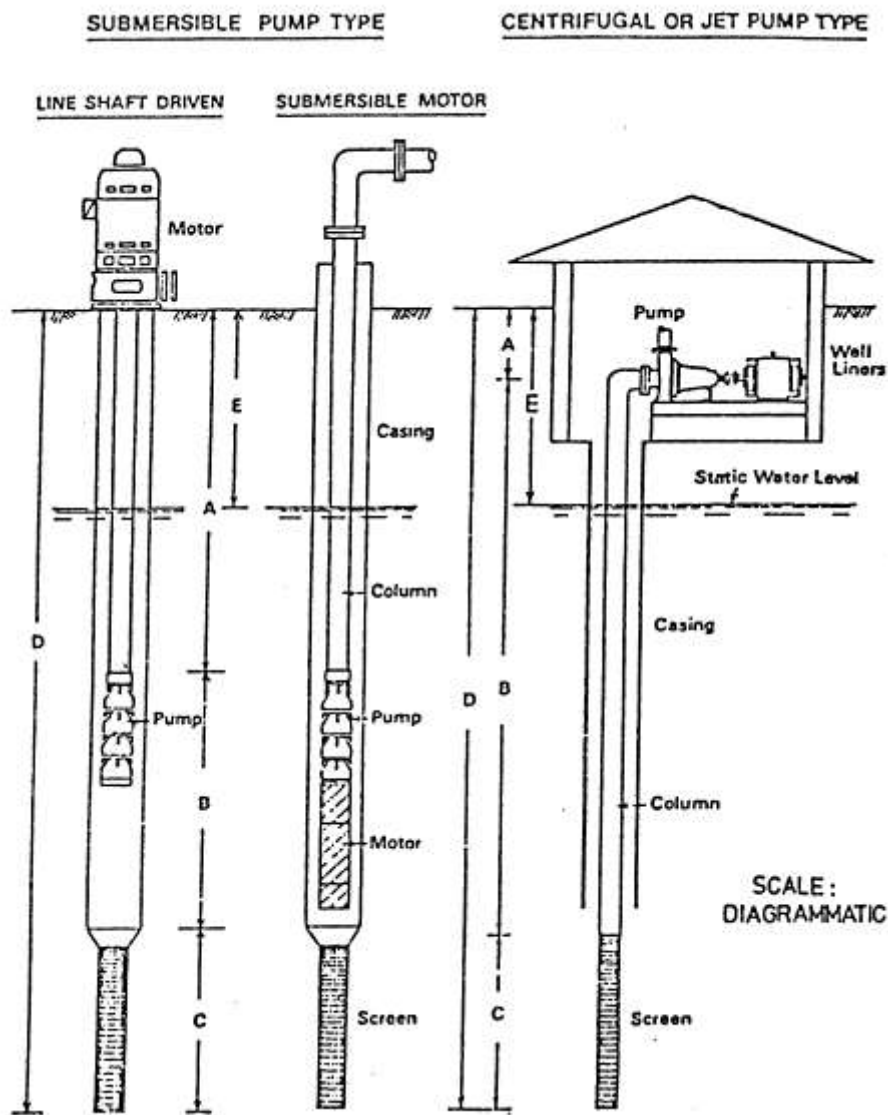

[Schedule B inserted in Gazette 31 July 1981 pp.3169-73; amended in Gazette 12 May 1989 pp.1445-6; 29 December 1995 p.6324.]



**Schedule C — Fees**

	\$
1. Fees to be paid in respect of proposals to carry out plumbing works —	
(a) For works to be connected to the sewer —	
(i) Single residential building —	
(I) one major fixture.....	69.80
(II) each additional major fixture.....	17.45
(III) re-inspection.....	34.90
(ii) Other than single residential building — single storey —	
(I) one major fixture.....	107.70
(II) each additional major fixture.....	35.90
(III) re-inspection.....	53.85
(iii) Other than single residential building — more than one storey — fee per floor —	
(I) one major fixture on floor.....	178.20
(II) each additional major fixture on floor.....	59.40
(III) re-inspection.....	89.10
(b) For works to be connected to a septic tank —	
(i) one major fixture.....	42.00
(ii) each additional major fixture.....	21.00
2. Fee for installation of sewer junction —	
100 mm sewer junction.....	262.65
150 mm sewer junction.....	325.65
3. Fees for authorization of materials, fittings and fixtures —	
(a) application —	
(i) first item of product type.....	340.00
(ii) each additional item of product type.....	47.40

**Schedule C Fees**

---

	\$
(b) examination, testing, inspection or evaluation (per hour or part of an hour).....	79.55
4. Fee for —	
(a) issue of a plumber’s licence — per quarter or part of a quarter.....	27.20
(b) renewal of a plumber’s licence.....	108.85
(c) duplicate instruments (licences and certificates).....	21.75
(d) application for a plumber’s licence.....	32.65
5. (a) Fee for installing a meter under by-law 6.7.1A.1....	212.60
(b) Fee for assessing a meter under by-law 6.7.1A.3....	150.95
(c) Fee for assessing a meter and installing a new meter under by-law 6.7.1A.4.....	197.20
6. Fee for installation of temporary building standpipe.....	81.00
7. Fee for inspection of work under by-law 30.9.4 —	
(a) single residential building.....	34.90
(b) other than single residential building — single storey .....	53.85
(c) other than single residential building — more than one storey — fee per floor.....	89.10
8. Fee for book of forms of —	
(a) notice and certificate of completion and compliance.....	16.35
(b) multi-entry plumbing certificate.....	6.25
9. Fees for the provision of plan sheets for preparation of diagrams of property sewer installations —	
(a) A4 size (per pad of 25 sheets).....	3.75
(b) A3 size (per pad of 25 sheets).....	7.10
(c) A1 size (per sheet).....	1.25

*[Schedule C inserted in Gazette 29 June 1999 pp.2786-7.]*

**Schedule D**

(By-law 28.6.2(a) and (b))

**Part 1 — Fixtures**

Baths	Laundry troughs
Basins	Shower recess bases
Sinks	

---

**Part 2 — Prohibited materials, fittings and fixtures**

Food waste disposal units  
Rubber or plastic olives in metallic water service fittings  
Non-demand operated urinal flushing devices

*[Schedule D inserted in Gazette 22 December 1989 p.4631.]*

=====

**Notes**

<sup>1</sup> This reprint is a compilation as at 5 May 2000 of the *Metropolitan Water Supply, Sewerage and Drainage By-laws 1981* and includes the amendments in the reprint published in the *Gazette* on 19 May 1997 and the amendments effected by the other by-laws referred to in the following Table.

**Table of By-laws**

<b>Citation</b>	<b>Gazettal</b>	<b>Commencement</b>	<b>Miscellaneous</b>
<i>Metropolitan Water Supply, Sewerage and Drainage By-laws 1981</i> (corrigendum 30 January 1981 p.488)	22 January 1981 pp.165-384	1 March 1981 (see by-law 1.0)	
(By-laws effecting amendments in the previous reprint are not referred to in this Table)			Previously reprinted as at 19 May 1997
<i>Water Agencies Amendment By-laws 1997, Part 5</i>	27 June 1997 pp.3204-20	1 July 1997 (see by-law 2)	By-law 3: application <sup>10</sup>
<i>Water Agencies Amendment By-laws 1998, Part 5</i>	26 June 1998 pp.3417-21	1 July 1998 (see by-law 2)	By-law 3: application <sup>11</sup>
<i>Metropolitan Water Supply, Sewerage and Drainage Amendment By-laws 1998</i>	25 August 1998 pp.4724-35	25 August 1998	
<i>Metropolitan Water Supply, Sewerage and Drainage Amendment By-laws (No. 2) 1998</i>	29 September 1998 p.5405	29 September 1998 (see by-law 2)	
<i>Water Agencies Amendment By-laws 1999, Part 6</i>	29 June 1999 pp.2775-87	1 July 1999 (see by-law 2)	By-law 3: application <sup>12</sup>

<sup>1a</sup> The power to make these by-laws is now contained in section 34 of the *Water Agencies (Powers) Act 1984* (No. 3 of 1984).

<sup>2</sup> Now Department of Conservation and Land Management.

<sup>3</sup> Now Health Department of Western Australia.

<sup>4</sup> Now Department of Minerals and Energy.

<sup>5</sup> The *Flammable Liquids Regulations 1967* were repealed by the *Dangerous Goods Regulations 1992*, regulation 8.2.

<sup>6</sup> See *Health Act 1911* (No. 34 of 1911).

<sup>7</sup> Section 147 of the *Metropolitan Water Supply, Sewerage, and Drainage Act 1909* was repealed by the *Acts Amendment and Repeal (Water Authorities) Act 1985* (No. 25 of 1985), section 76.

<sup>8</sup> Repealed by the *Local Government Act 1995* (No. 74 of 1995) section 9.70.

<sup>9</sup> See the *Strata Titles Act 1985* (No. 33 of 1985).

<sup>10</sup> By-law 3 of the *Water Agencies Amendment By-laws 1997* reads as follows —

“

**3. Application**

Nothing in these by-laws affects the application after 1 July 1997 of a by-law in force before that day in so far as that by-law relates to a fee or charge for a period commencing before that day or to a fee or charge for any matter or thing done before that day.

”

<sup>11</sup> By-law 3 of the *Water Agencies Amendment By-laws 1998* reads as follows —

“

**3. Application**

Nothing in these by-laws affects the application after 1 July 1998 of a by-law in force before that day in so far as that by-law relates to a fee or charge for a period commencing before that day or to a fee or charge for any matter or thing done before that day.

”

<sup>12</sup> By-law 3 of the *Water Agencies Amendment By-laws 1999* reads as follows —

“

**3. Application**

Nothing in these by-laws affects the application after 1 July 1999 of a by-law in force before that day in so far as that by-law relates to a fee or charge for a period commencing before that day or to a fee or charge for any matter or thing done before that day.

”

**Defined Terms**

---

**Defined Terms**

*[This is a list of terms defined and the provisions where they are defined.  
The list is not part of the law.]*

<b>Defined Term</b>	<b>Provision(s)</b>
Approved .....	1.1
AS/NZS .....	1.1
automotive business premises .....	5.6.1
Backflow .....	1.1
Board.....	28.2.4
book of forms .....	30.9.1
Bore.....	1.1
Branch property sewer .....	1.1
bulk liquid storage tank system.....	5.6.1
certificate .....	30.9.1
combined waste pipe.....	28.9.3.2
Commercial Type.....	1.1
Container.....	1.1
Cross Connection .....	1.1
Diameter.....	1.1
Discharge Pipe .....	1.1
Disconnecter Trap.....	1.1
Domestic Purposes.....	1.1
Domestic Sewage .....	1.1
Domestic Type .....	1.1
Drainage Plumbing .....	1.1
Educt Vent .....	1.1
elevated storage tank system.....	5.6.1
emergency work.....	30.9.1
establish .....	5.6.1
exempt building .....	27.3.1
Feeder.....	1.1
Flat .....	1.1
ground storage tank system.....	5.6.1
Ground .....	1.1
High-Water Mark.....	1.1
Indirectly Connected .....	1.1
Induct vent .....	1.1
Industrial Waste .....	1.1
Inspector.....	1.1
joint water service .....	12.1.1
Licensed Plumber.....	1.1
major fixtures .....	27.3.4(a)
multi-entry plumbing certificate .....	30.9.1

**Defined Terms**

---

multi-entry work .....	30.9.1
multi-unit development .....	6.7.1A.5
notice.....	30.9.1
notified work .....	30.9.1
Observation Well .....	1.1
owner .....	5.6.1
Pesticides .....	1.1
Pipework .....	1.1
plans .....	5.6.1
Plumber's Licence .....	1.1
priority 1 source protection area .....	5.6.1
priority 2 source protection area .....	5.6.1
priority 3 source protection area .....	5.6.1
Private Service .....	1.1
Production Well .....	1.1
Residential Building.....	1.1
Sanitary Plumbing.....	1.1
Size.....	1.1
Spill Level.....	1.1
tank.....	5.6.1
The Act .....	1.1
the first licensed plumber .....	30.9.4A.1
the old device .....	19.3.1(f)
Trade Waste .....	1.1
Trap Seal .....	1.1
unpolluted water.....	5.6.1
Vent Pipe.....	1.1
Vent Stack.....	1.1
Vented.....	1.1
Waste Pipe .....	1.1
Water Heater .....	1.1
Water Seal.....	1.1
Water Service.....	1.1
Water Supply Plumbing .....	1.1
Water Supply System.....	1.1
wellhead protection zone .....	5.6.1
wellhead .....	5.6.1
working day .....	30.9.1
Yard Gully .....	1.1